

ELIOT TOWER CONDOMINIUMS

BLOCK 246, "CITY OF PORTLAND"
 TOGETHER WITH THE SOUTHERLY 30 FEET OF VACATED SW MADISON STREET,
 SITUATED IN THE NORTHEAST 1/4 OF SECTION 4, TOWNSHIP 1 SOUTH, RANGE 1 EAST,
 WILLAMETTE MERIDIAN, CITY OF PORTLAND, MULTNOMAH COUNTY, OREGON
 MARCH 7, 2006

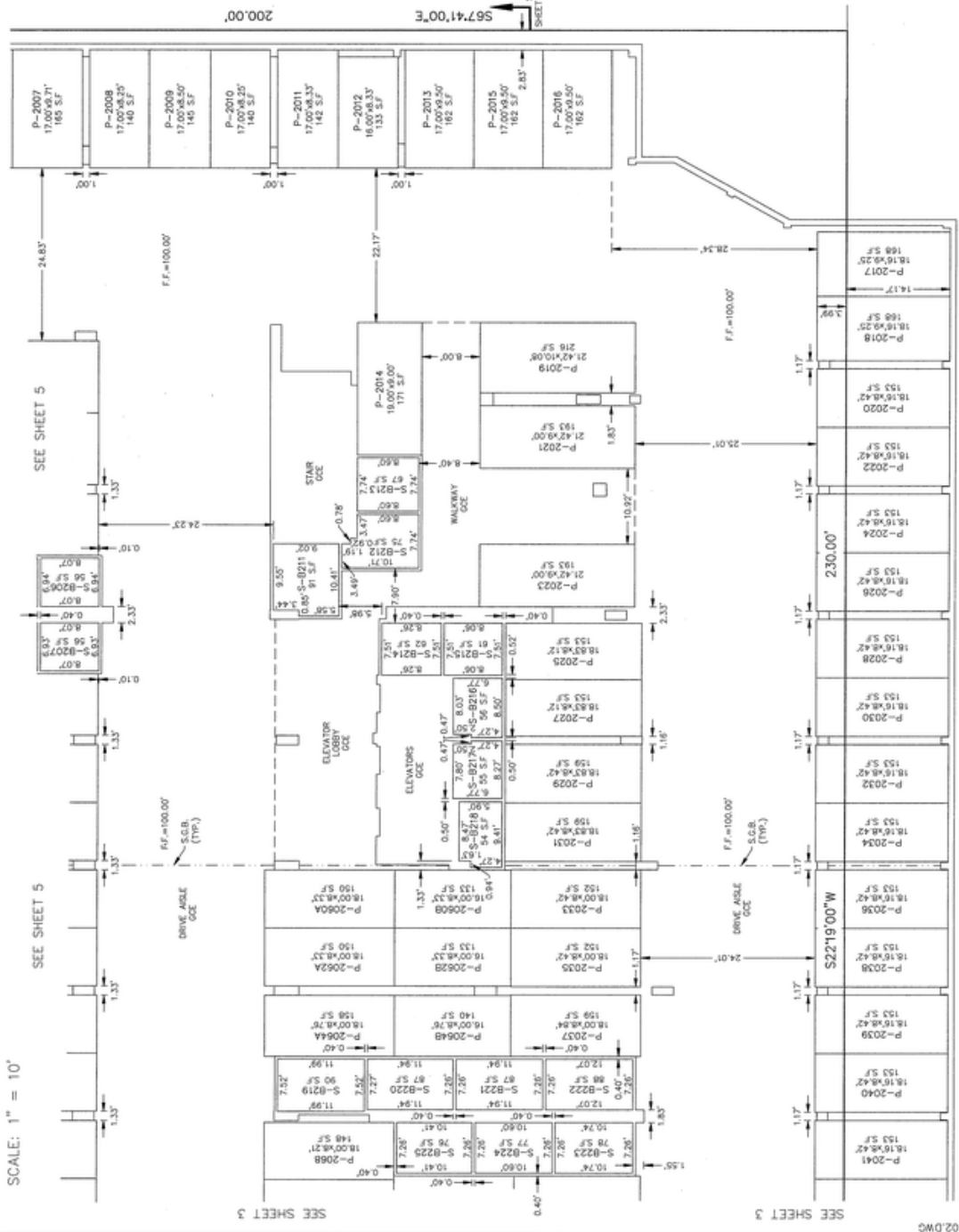

SCALE: 1" = 10'



LEGEND

P-###	PARKING UNIT NUMBER
S-###	STORAGE UNIT NUMBER
###	GENERAL COMMON ELEMENT
COE	LIMITED COMMON ELEMENT
S.F.	SQUARE FEET
FF.	FINISHED FLOOR ELEVATION
S.G.B.	SLAB GRADE BREAK
(TYP.)	TYPICAL

NOTES

1. ALL WALLS ARE PARALLEL, PERPENDICULAR OR AT 45 DEGREES TO THE SOUTH OR EAST BOUNDARY LINES SHOWN, UNLESS OTHERWISE NOTED.
2. EXTERIOR THICKNESS SHOWN HEREON REPRESENT THE DIMENSION FROM THAT APPLICABLE BOUNDARY OTHERWISSE NOTED.
3. AREAS UNLABELED BETWEEN UNITS, OR UNITS AND HALLS ARE COE UNLESS NOTED OTHERWISE.
4. FLOOR ELEVATION VARIES. SEE F.F. ELEVATIONS AND SLAB GRADE BREAKS FOR LOCATIONS AND ELEVATIONS. SEE SHEET 47 FOR BENCHMARK.

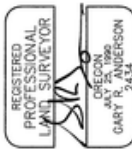

REGISTERED PROFESSIONAL LAND SURVEYOR
 OREGON
 JULY 25, 1995
 GARY R. ANDERSON
 74324

RENEWAL DATE
LOWER BASEMENT
NORTHEAST 1/4

I HEREBY CERTIFY THIS TO BE A TRUE AND EXACT COPY OF THE ORIGINAL PLAT

 GARY R. ANDERSON P.L.S. NO. 2434

SURVEYED BY:
WESTLAKE CONSULTANTS, INC.
 15115 S.W. SEQUOIA PARKWAY, SUITE 150
 TIGARD, OREGON 97224
 (503)884-0652

ELIOT TOWER CONDOMINIUMS

BLOCK 246, "CITY OF PORTLAND"
 TOGETHER WITH THE SOUTHERLY 30 FEET OF VACATED SW MADISON STREET,
 SITUATED IN THE NORTHEAST 1/4 OF SECTION 4, TOWNSHIP 1 SOUTH, RANGE 1 EAST,
 WILLAMETTE MERIDIAN, CITY OF PORTLAND, MULTNOMAH COUNTY, OREGON
 MARCH 7, 2006



SCALE: 1" = 10'

LEGEND

- P-## PARKING UNIT NUMBER
- S-## STORAGE UNIT NUMBER
- GZE GENERAL COMMON ELEMENT
- LCE LIMITED COMMON ELEMENT
- S.F. SQUARE FEET
- FF. FINISHED FLOOR ELEVATION
- S.G.B. SLAB GRADE BREAK (TYP.)

NOTES

1. ALL WALLS ARE PARALLEL, PERPENDICULAR OR AT 45 DEGREE ANGLES TO EACH OTHER UNLESS SHOWN UNLESS OTHERWISE NOTED.
2. EXTERIOR THICKNESS SHOWN HEREON REPRESENT THE DIMENSION FROM THAT APPLICABLE BOUNDARY LINE TO THE INTERIOR WALL SURFACE, UNLESS OTHERWISE NOTED.
3. AREAS UNLABELED BETWEEN UNITS OR UNITS AND HALLS ARE GZE, UNLESS NOTED OTHERWISE.
4. FLOOR ELEVATION VARIES. SEE FF. ELEVATIONS FOR FLOOR FINISH ELEVATIONS. SEE SHEET 47 FOR BENCHMARK ELEVATIONS.

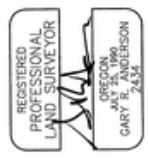

RENEWAL DATE
 12-31-07

LOWER BASEMENT SOUTHEAST 1/4

I HEREBY CERTIFY THIS TO BE A TRUE AND
 EXACT COPY OF THE ORIGINAL PLAT

GARY R. ANDERSON P.L.S. NO. 2434

SURVEYED BY:
 WESTLAKE CONSULTANTS, INC.
 15115 S.W. SEGUNDA PARKWAY, SUITE 150
 TIGARD, OREGON 97224
 (503)684-0852

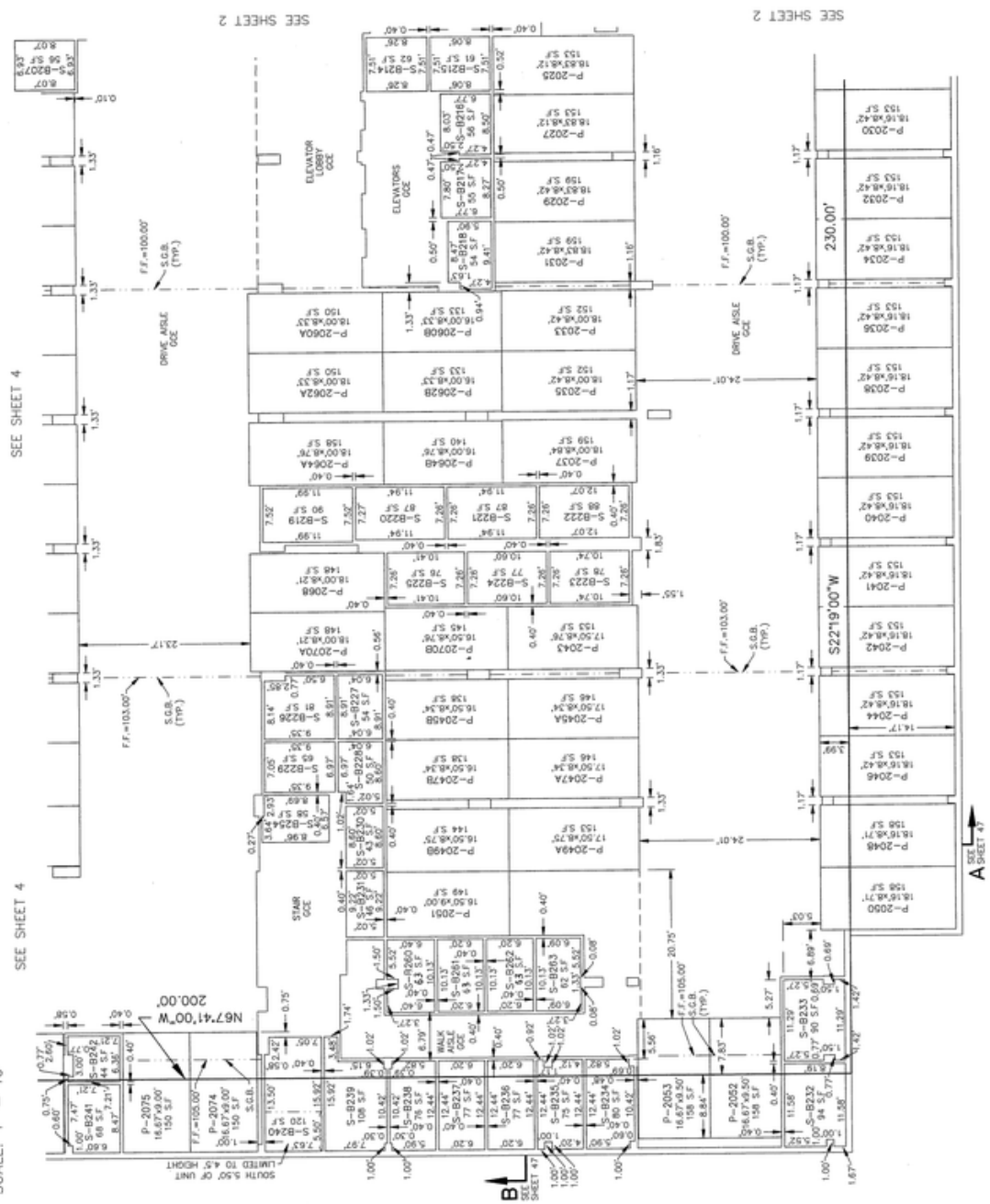

ELIOT TOWER CONDOMINIUMS

BLOCK 246, "CITY OF PORTLAND"
 TOGETHER WITH THE SOUTHERLY 30 FEET OF VACATED SW MADISON STREET,
 SITUATED IN THE NORTHEAST 1/4 OF SECTION 4, TOWNSHIP 1 SOUTH, RANGE 1 EAST,
 WILLAMETTE MERIDIAN, CITY OF PORTLAND, MULTNOMAH COUNTY, OREGON
 MARCH 7, 2006



SCALE: 1" = 10'

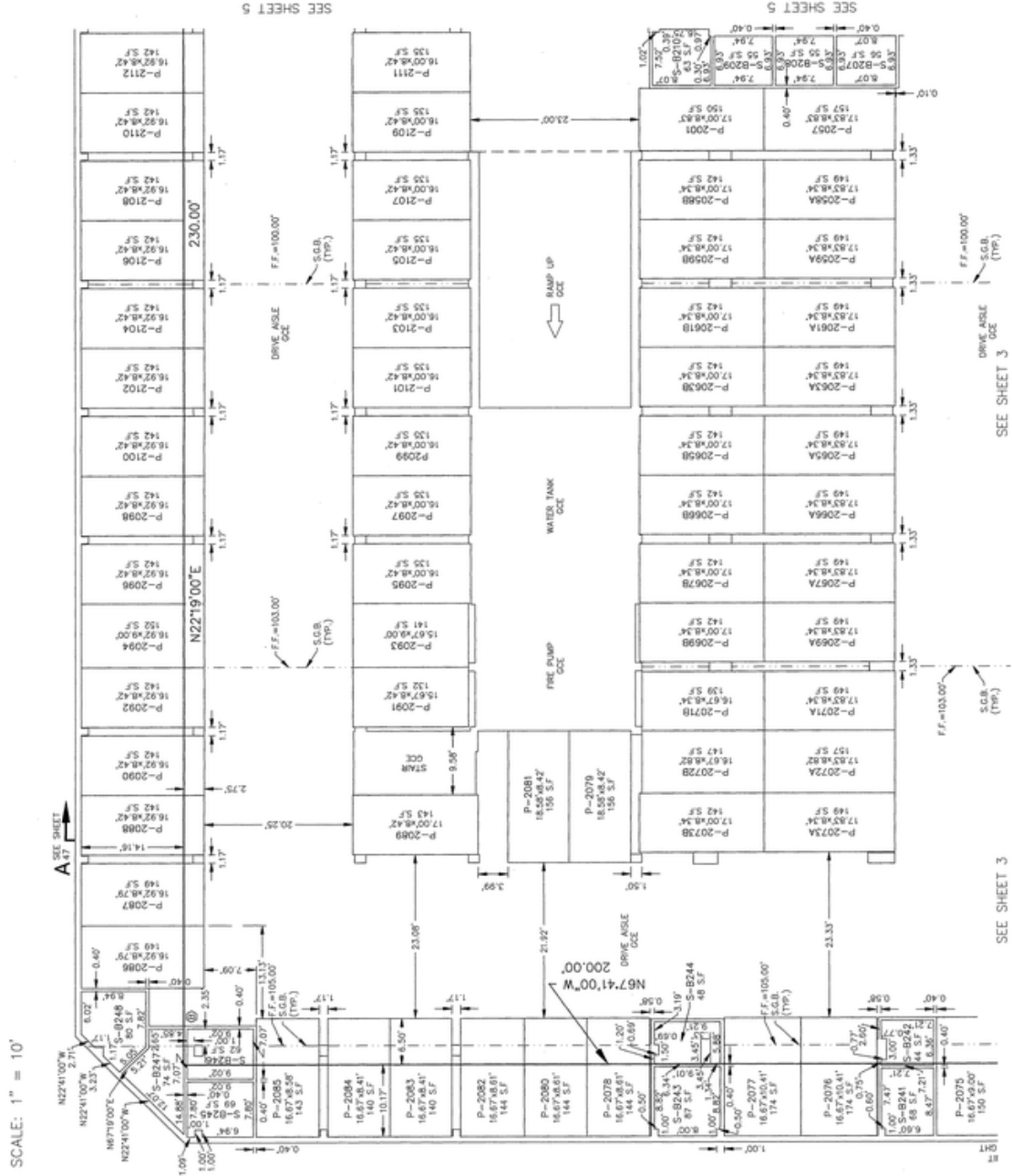

LEGEND
 P-### PARKING UNIT NUMBER
 S-### STORAGE UNIT NUMBER
 GCE GENERAL COMMON ELEMENT
 S.F. SQUARE FEET
 F.F. FINISHED FLOOR ELEVATION
 S.G.B. SLAB GRADE BREAK
 O COLUMN TYPE

COLUMN TYPE DETAIL

NOTES

1. ALL WALLS ARE PARALLEL, PERPENDICULAR OR AT 45 DEGREES TO THE SOUTH OR EAST BOUNDARY LINES SHOWN, UNLESS OTHERWISE NOTED.
2. EXTERIOR THICKNESS SHOWN REPRESENTS THE CENTERLINE OF THE EXTERIOR WALL SURFACE, UNLESS OTHERWISE NOTED.
3. AREAS UNLABELED BETWEEN UNITS, OR UNITS AND WALLS ARE OCE, UNLESS NOTED OTHERWISE.
4. FLOOR ELEVATION MARKS, SEE F.F. ELEVATIONS AND SLAB GRADE BREAKS FOR LOCATIONS AND ELEVATIONS. SEE SHEET 47 FOR BENCHMARK.

REGISTERED PROFESSIONAL LAND SURVEYOR
 GARY R. ANDERSSON
 1000 N.W. 23rd Ave.
 Astoria, OR 97103
 503-325-7434

RENEWAL DATE
 12-31-07

LOWER BASEMENT
 SOUTHWEST 1/4

LIBRARY COPY THIS TO BE A TRUE AND EXACT COPY OF THE ORIGINAL PLAT

GARY R. ANDERSSON P.L.S. NO. 2434

SURVEYED BY:
 WESTLAKE CONSULTANTS, INC.
 15115 S.W. SEQUOIA PARKWAY, SUITE 150
 TIGARD, OREGON 97224
 (503)584-0652

1042-08(8)

SHEET 4 OF 48

ELIOT TOWER CONDOMINIUMS

BLOCK 246, "CITY OF PORTLAND"
 TOGETHER WITH THE SOUTHERLY 30 FEET OF VACATED SW MADISON STREET,
 SITUATED IN THE NORTHEAST 1/4 OF SECTION 4, TOWNSHIP 1 SOUTH, RANGE 1 EAST,
 WILLAMETTE MERIDIAN, CITY OF PORTLAND, MULTNOMAH COUNTY, OREGON
 MARCH 7, 2006

SCALE: 1" = 10'

LEGEND

- P-## PARKING UNIT NUMBER
- S-## STORAGE UNIT NUMBER
- OCE GENERAL COMMON ELEMENT
- S.F. SQUARE FEET
- F.F. FINISHED FLOOR ELEVATION
- S.C.B. SLAB GRADE BREAK (TYP.)

NOTES

1. ALL WALLS ARE PARALLEL, PERPENDICULAR OR AT 45 DEGREES TO THE ADJACENT BOUNDARY LINES SHOWN, UNLESS OTHERWISE NOTED.
2. EXTERIOR THICKNESS DIMENSIONS REPRESENT THE DIMENSION FROM THAT APPLICABLE BOUNDARY LINE TO THE INTERIOR WALL SURFACE, UNLESS OTHERWISE NOTED.
3. AREAS UNLABELED BETWEEN UNITS, OR UNITS AND WALLS ARE OCE, UNLESS NOTED OTHERWISE.
4. FLOOR ELEVATION VARIES. SEE F.F. ELEVATIONS AND SLAB GRADE BREAKS FOR LOCATIONS AND ELEVATIONS. SEE SHEET 4 FOR BENCHMARK.

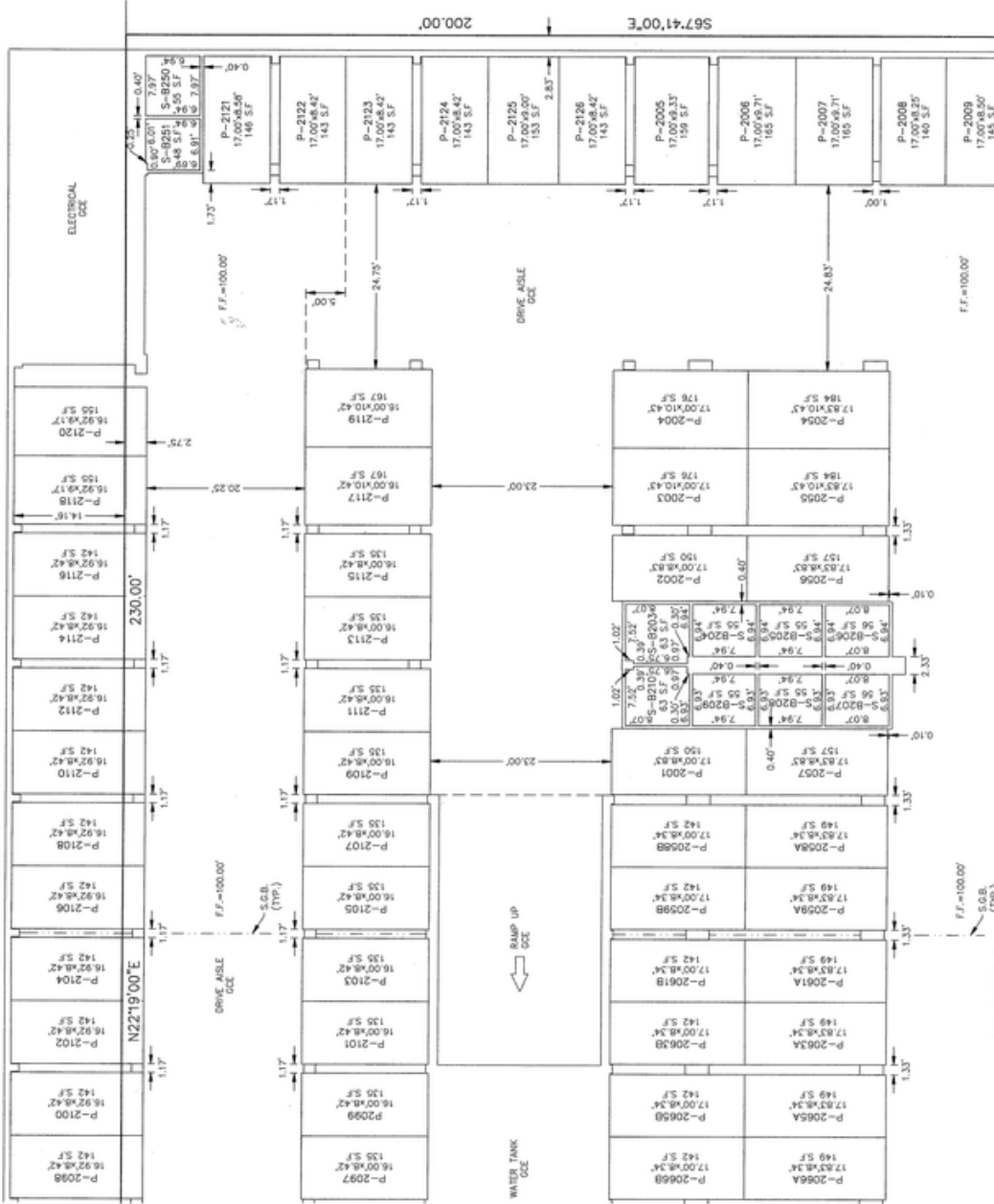

ELIOT TOWER CONDOMINIUMS

BLOCK 246, "CITY OF PORTLAND"
 TOGETHER WITH THE SOUTHERLY 30 FEET OF VACATED SW MADISON STREET,
 SITUATED IN THE NORTHEAST 1/4 OF SECTION 4, TOWNSHIP 1 SOUTH, RANGE 1 EAST,
 WILLAMETTE MERIDIAN, CITY OF PORTLAND, MULTNOMAH COUNTY, OREGON
 MARCH 7, 2006



SCALE: 1" = 10'

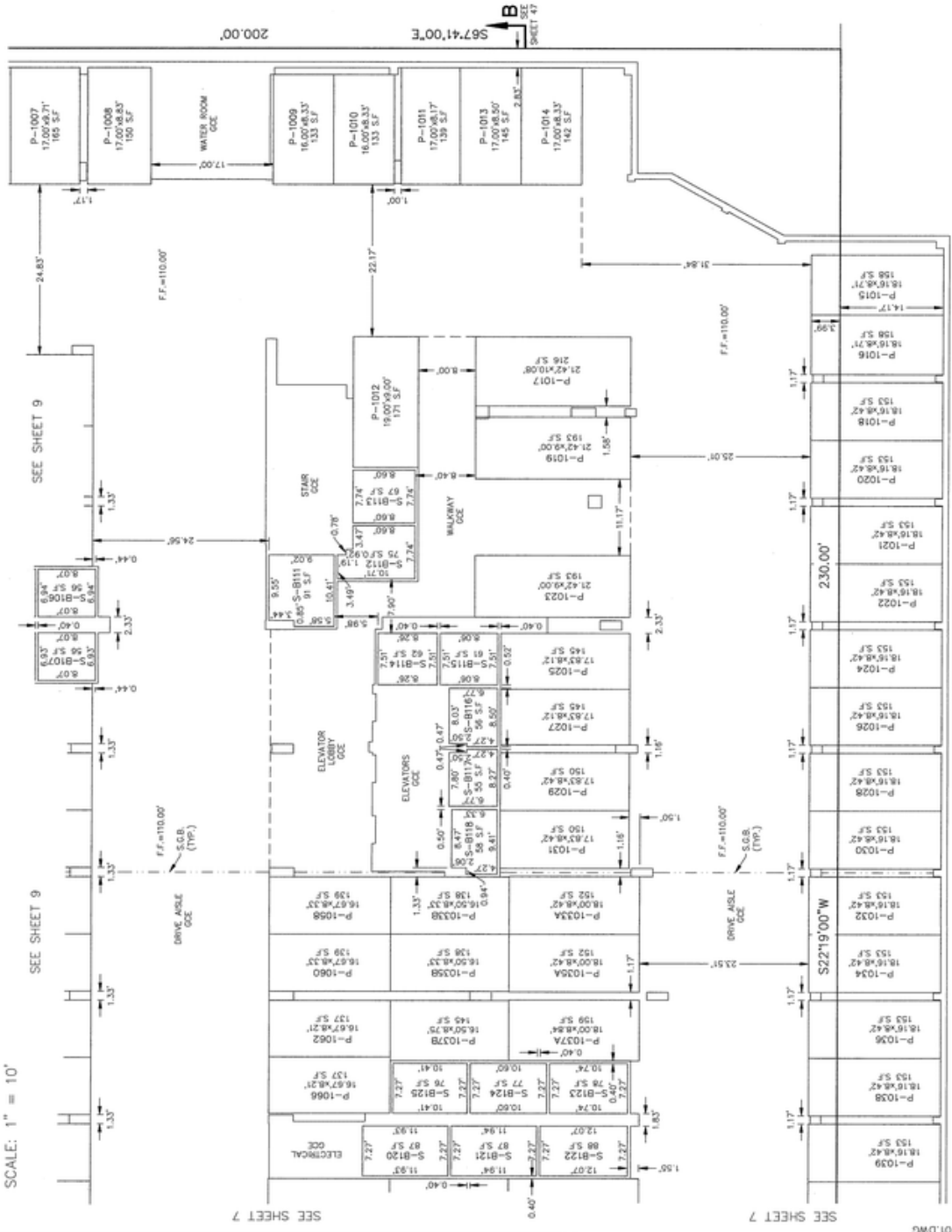

- LEGEND**
- P-### PARKING UNIT NUMBER
 - S-### STORAGE UNIT NUMBER
 - GCE GENERAL COMMON ELEMENT
 - LCE LIMITED COMMON ELEMENT
 - S.F. SQUARE FEET
 - FF. FINISHED FLOOR ELEVATION
 - S.O.B. SLAB GRADE BREAK (TYP.)

- NOTES**
1. ALL WALLS ARE PARALLEL, PERPENDICULAR OR AT 45 DEGREES TO THE SOUTH OR EAST BOUNDARY LINES SHOWN, UNLESS OTHERWISE NOTED.
 2. EXTENSION THICKNESS SHOWN HEREON REPRESENT THE DIMENSION FROM THAT APPLICABLE BOUNDARY THEREON, UNLESS NOTED.
 3. UNLESS OTHERWISE NOTED, DIMENSIONS OF UNITS AND WALLS ARE G.C.E. UNLESS NOTED OTHERWISE.
 4. FLOOR FINISHES, FINISHES, FINISH ELEVATIONS AND FINISH THICKNESS SHOWN HEREON REPRESENT THE DIMENSION FROM THAT APPLICABLE BOUNDARY THEREON, UNLESS NOTED.
 5. SEE SHEET 47 FOR BENCHMARK ELEVATIONS.

REGISTERED
 PROFESSIONAL
 LAND SURVEYOR
 GARY R. ANDERSON
 P.L.S. NO. 2454

RENEWAL DATE
 12-31-07
 UPPER BASEMENT
 NORTHEAST 1/4
 I HEREBY CERTIFY THIS TO BE A TRUE AND
 EXACT COPY OF THE ORIGINAL PLAT
 GARY R. ANDERSON P.L.S. NO. 2454

SURVEYED BY:
 WESTLAKE CONSULTANTS, INC.
 1315 S.W. SEQUOIA PARKWAY, SUITE 150
 PORTLAND, OREGON 97224
 (503)684-6632

ELIOT TOWER CONDOMINIUMS

BLOCK 246, "CITY OF PORTLAND"
 TOGETHER WITH THE SOUTHERLY 30 FEET OF VACATED SW MADISON STREET,
 SITUATED IN THE NORTHEAST 1/4 OF SECTION 4, TOWNSHIP 1 SOUTH, RANGE 1 EAST,
 WILLAMETTE MERIDIAN, CITY OF PORTLAND, MULTNOMAH COUNTY, OREGON
 MARCH 7, 2006



SCALE: 1" = 10'

LEGEND

- P-### PARKING UNIT NUMBER
- S-### STORAGE UNIT NUMBER
- GCE GENERAL COMMON ELEMENT
- LCE LIMITED COMMON ELEMENT
- SF SQUARE FEET
- FF FINISHED FLOOR ELEVATION

NOTES

1. ALL WALLS ARE PARALLEL, PERPENDICULAR OR AT 45 DEGREE ANGLES TO ADJACENT BOUNDARY LINES UNLESS OTHERWISE NOTED.
2. EXTERIOR THICKNESS SHOWN HEREIN REPRESENTS THE DIMENSION FROM THAT APPLICABLE BOUNDARY LINE TO THE INTERIOR WALL SURFACE, UNLESS OTHERWISE NOTED.
3. AREAS UNLABLED BETWEEN UNITS, OR UNITS AND HALLS ARE GCE, UNLESS NOTED OTHERWISE.
4. FLOOR ELEVATION VARIES. SEE FF ELEVATIONS AND 3-D GROUND BREAKDOWN LOGS AND ELEVATIONS. SEE SHEET 47 FOR BENCHMARK.

REGISTERED PROFESSIONAL LAND SURVEYOR
 OREGON
 GARY R. ANDERSON
 2434

RENEWAL DATE 12-31-07
 UPPER BASEMENT
 SOUTHEAST 1/4

I HEREBY CERTIFY THIS TO BE A TRUE AND EXACT COPY OF THE ORIGINAL PLAT
 GARY R. ANDERSON P.L.S. NO. 2434

SURVEYED BY:
 WESTLAKE CONSULTANTS, INC.
 15115 S.W. SEQUOIA PARKWAY, SUITE 150
 TIGARD, OREGON 97224
 (503)864-0852

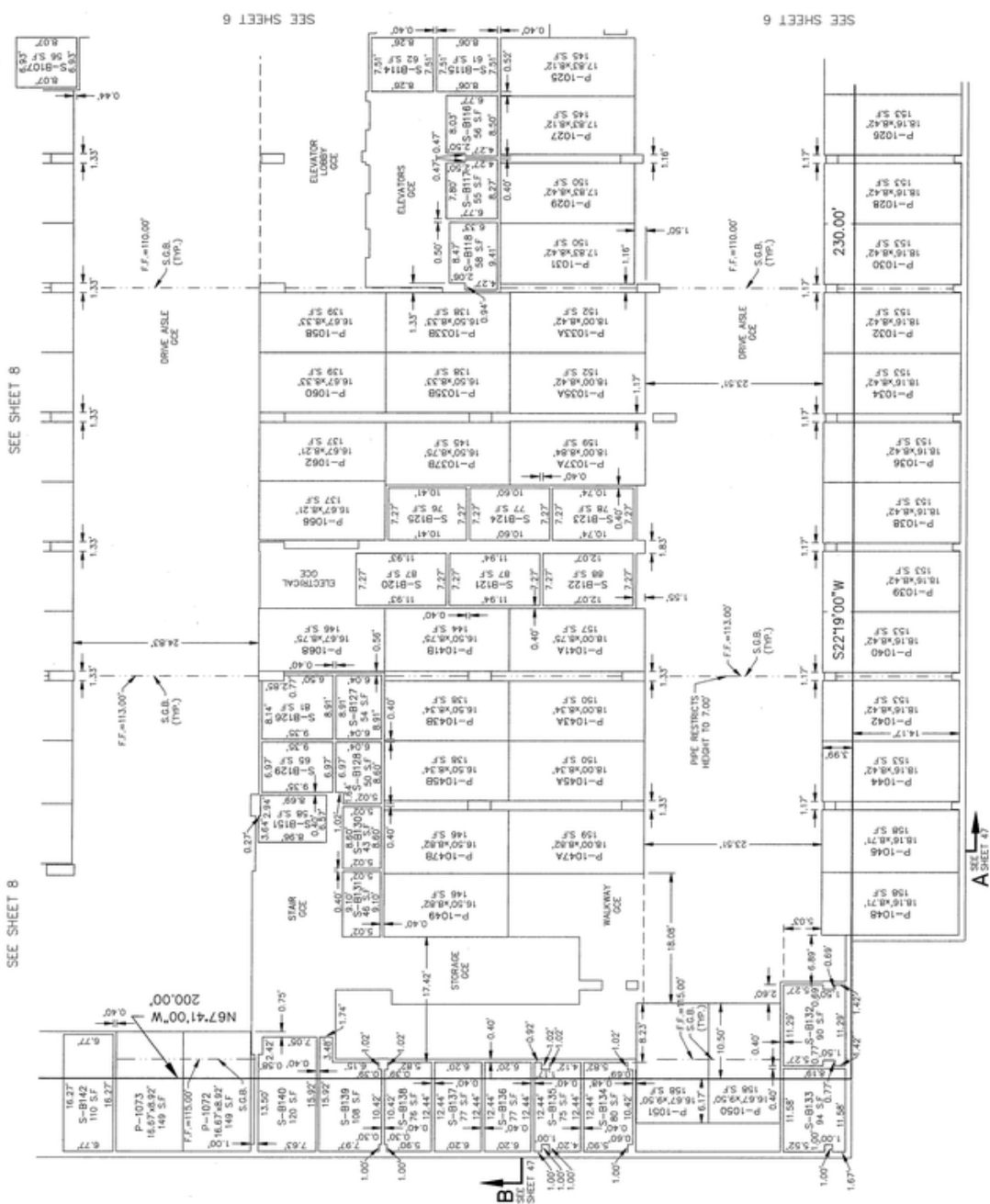

ELIOT TOWER CONDOMINIUMS

BLOCK 246, "CITY OF PORTLAND"
 TOGETHER WITH THE SOUTHERLY 30 FEET OF VACATED SW MADISON STREET,
 SITUATED IN THE NORTHEAST 1/4 OF SECTION 4, TOWNSHIP 1 SOUTH, RANGE 1 EAST,
 WILLAMETTE MERIDIAN, CITY OF PORTLAND, MULTNOMAH COUNTY, OREGON
 MARCH 7, 2006



SCALE: 1" = 10'

- LEGEND**
- P-## PARKING UNIT NUMBER
 - S-## STORAGE UNIT NUMBER
 - GENERAL COMMON ELEMENT
 - SF SQUARE FEET
 - FF FINISHED FLOOR ELEVATION
 - S.G.B. SLAB GRADE BREAK
 - COLUMN TYPE

COLUMN TYPE DETAIL



NOTES

1. ALL WALLS ARE PARALLEL, PERPENDICULAR OR AT 45 DEGREES TO THE SOUTH OR EAST BOUNDARY LINES SHOWN, UNLESS OTHERWISE NOTED.
2. EXTERIOR THICKNESS SHOWN HEREIN REPRESENTS THE DIMENSION FROM THAT APPLICABLE BOUNDARY DIMENSION NOTED.
3. AREAS UNLabeled REFERRED UNITS OR UNITS AND WALLS ARE O.C.E. UNLESS NOTED OTHERWISE.
4. FLOOR ELEVATION VARIES. SEE FF. ELEVATIONS FOR DETAILS. SEE SHEET 47 FOR BENCHMARK ELEVATIONS. SEE SHEET 47 FOR BENCHMARK.

REGISTERED
 PROFESSIONAL
 LAND SURVEYOR
 GARY R. ANDERSON
 P.L.S. NO. 2434

RENEWAL DATE
 12-31-07

UPPER BASEMENT SOUTHWEST 1/4

I HEREBY CERTIFY THIS TO BE A TRUE AND
 EXACT COPY OF THE ORIGINAL PLAT

GARY R. ANDERSON P.L.S. NO. 2434

SURVEYED BY:
 WESTLAKE CONSULTANTS, INC.
 15115 S.W. SEQUOIA PARKWAY, SUITE 150
 PORTLAND, OREGON 97224
 (503)864-0052

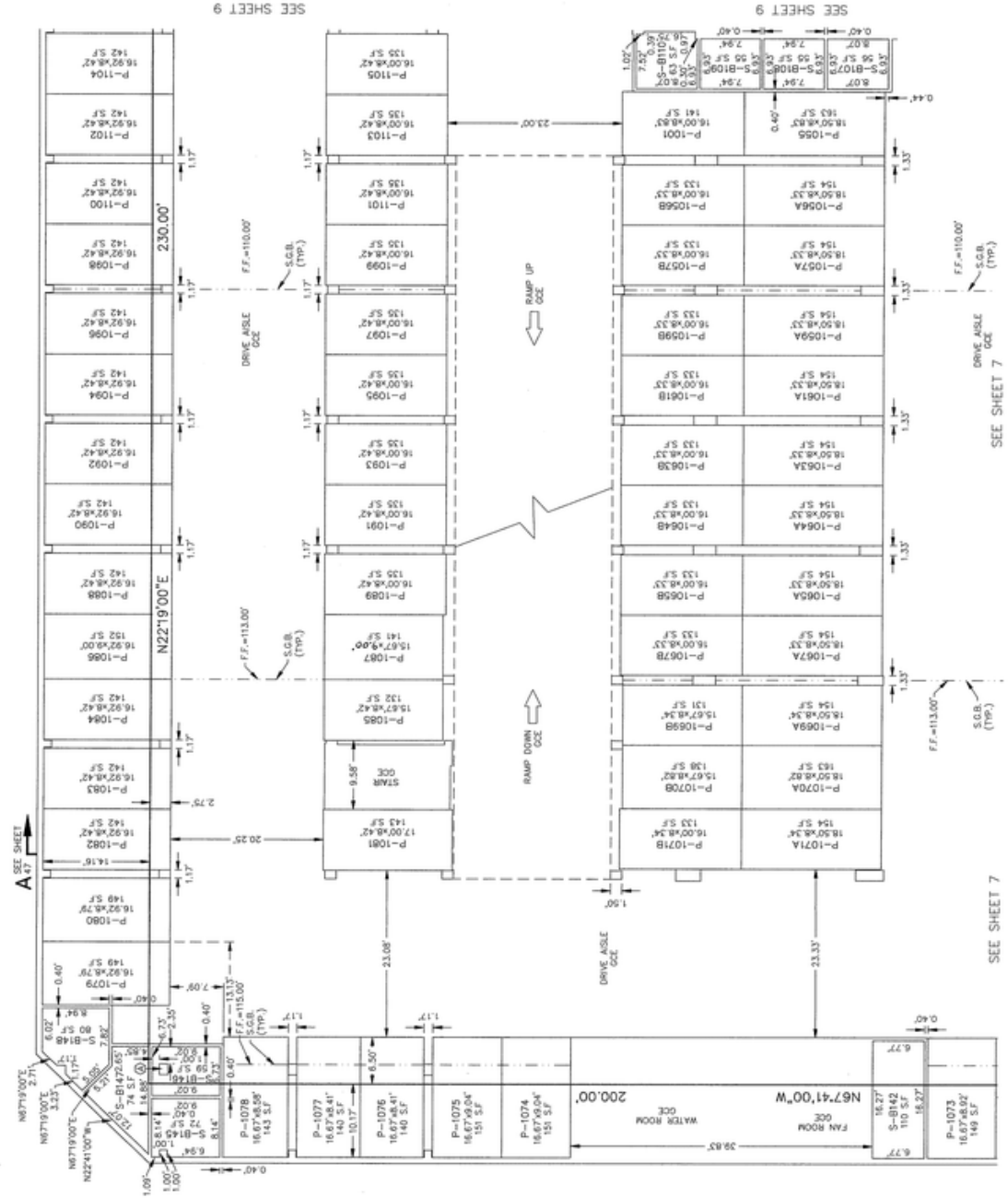

ELIOT TOWER CONDOMINIUMS

BLOCK 246, "CITY OF PORTLAND"
 TOGETHER WITH THE SOUTHERLY 30 FEET OF VACATED SW MADISON STREET,
 SITUATED IN THE NORTHEAST 1/4 OF SECTION 4, TOWNSHIP 1 SOUTH, RANGE 1 EAST,
 WILLAMETTE MERIDIAN, CITY OF PORTLAND, MULTNOMAH COUNTY, OREGON
 MARCH 7, 2006



SCALE: 1" = 10'

LEGEND

- P-### PARKING UNIT NUMBER
- S-### STORAGE UNIT NUMBER
- ### COMMON ELEMENT
- ### SQUARE FEET OR ELEVATION
- S.F. SQUARE FEET OR ELEVATION
- S.G.B. SLAB GRADE BREAK
- (TYP.) TYPICAL

NOTES

1. WALLS ARE PARALLEL, PERPENDICULAR OR AT AN ANGLE TO THE SOUTH OR EAST BOUNDARY LINES SHOWN, UNLESS OTHERWISE NOTED.
2. EXTERIOR THICKNESS SHOWN HEREON REPRESENTS THE DIMENSION FROM THAT APPLICABLE BOUNDARY LINE TO THE INTERIOR WALL SURFACE, UNLESS OTHERWISE NOTED.
3. AREAS UNLABELED BETWEEN UNITS, OR UNITS AND HALLS ARE O.C.E. UNLESS NOTED OTHERWISE.
4. FLOOR ELEVATION VARIES. SEE F.F. ELEVATIONS AND DRIVE ANGLE ELEVATIONS FOR FLOOR AND ELEVATIONS. SEE SHEET 47 FOR BENCHMARK.



RENEWAL DATE
 12-31-07

UPPER BASEMENT
 NORTHWEST 1/4

I HEREBY CERTIFY THIS TO BE A TRUE AND EXACT COPY OF THE ORIGINAL PLAT

GARY R. ANDERSON P.L.S. NO. 2454

SURVEYED BY:
 WESTLAKE CONSULTANTS, INC.
 15115 S.W. SEQUOIA PARKWAY, SUITE 150
 TIGARD, OREGON 97224
 (503)684-0652

104208F-01.DWG SHEET 9 OF 48

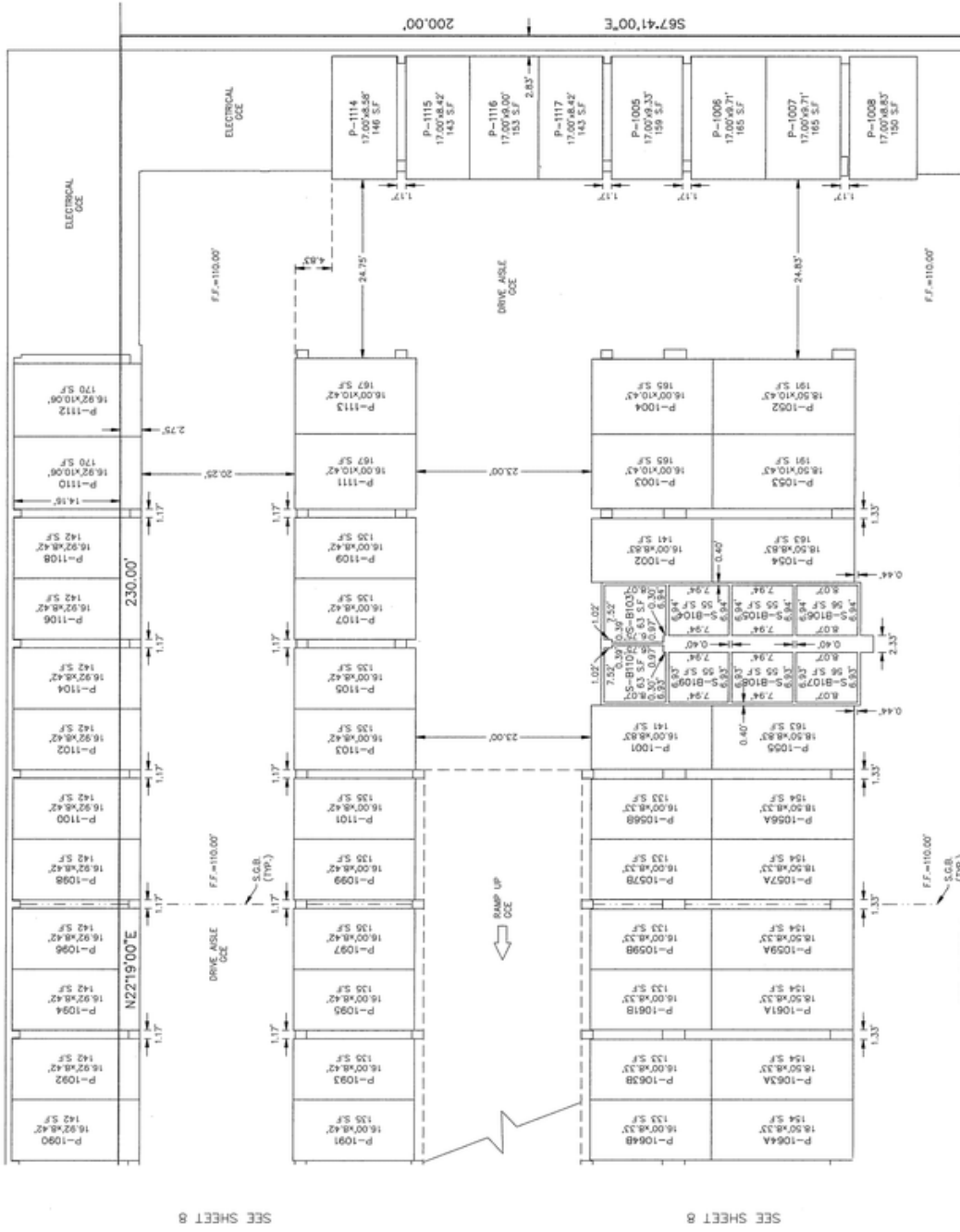

SEE SHEET 8

SEE SHEET 8

SEE SHEET 6

SEE SHEET 6

ELIOT TOWER CONDOMINIUMS

BLOCK 246, "CITY OF PORTLAND"
 TOGETHER WITH THE SOUTHERLY 30 FEET OF VACATED SW MADISON STREET,
 SITUATED IN THE NORTHEAST 1/4 OF SECTION 4, TOWNSHIP 1 SOUTH, RANGE 1 EAST,
 WILLAMETTE MERIDIAN, CITY OF PORTLAND, MULTNOMAH COUNTY, OREGON
 MARCH 7, 2006

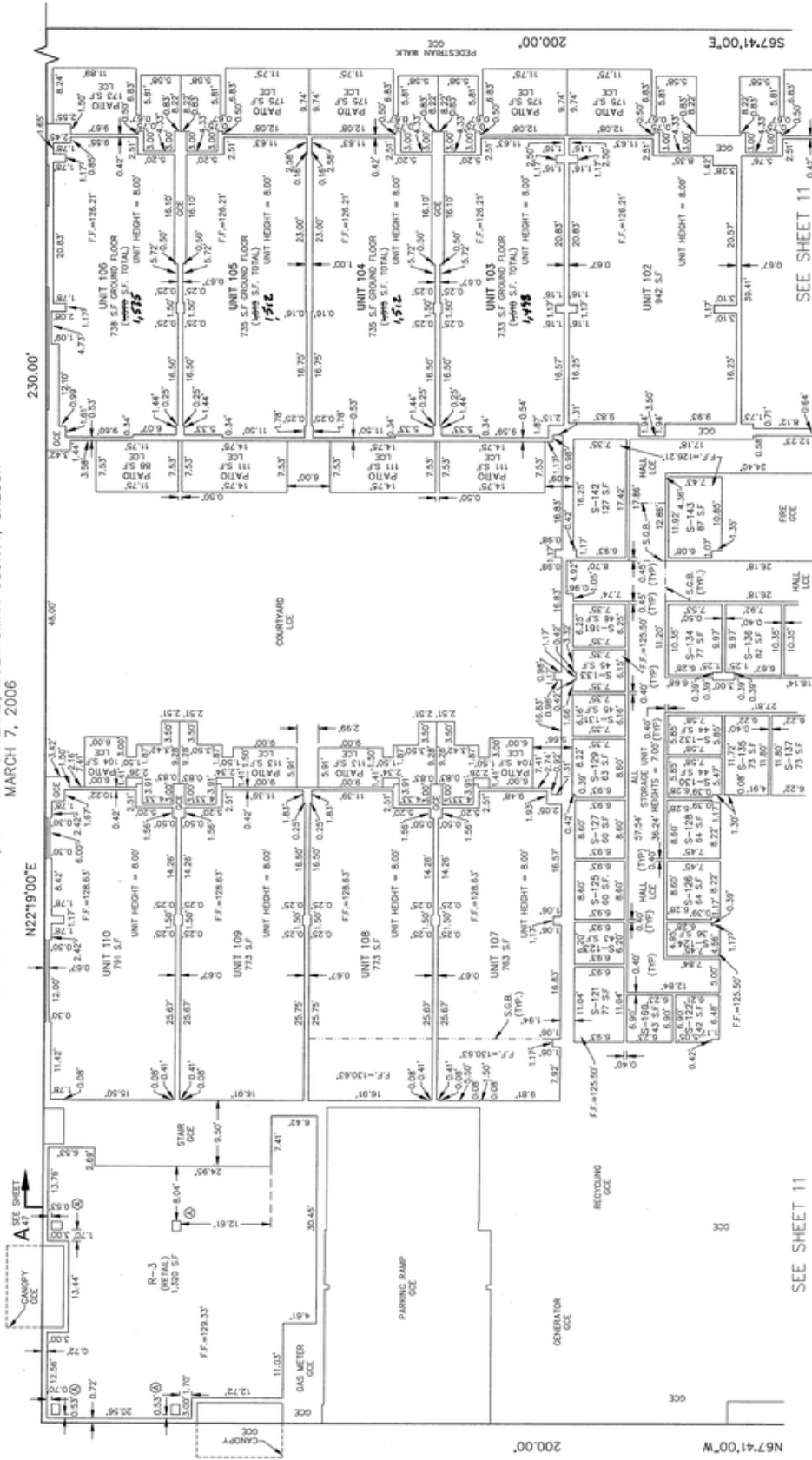

GROUND FLOOR - WEST



SURVEYED BY:
 WESTLAKE CONSULTANTS, INC.
 15115 S.W. SEQUOIA PARKWAY, SUITE 150
 TIGARD, OREGON 97224
 (503)864-0652

PLS. NO. 2434

- LEGEND**
- UNIT-### PRIMARY UNIT (RESIDENTIAL)
 - R-### PRIMARY UNIT (RETAIL)
 - S-### STORAGE UNIT (LCE)
 - ### GENERAL COMMON ELEMENT
 - LCE LCE
 - ### S.G.B. FINISHED FLOOR ELEVATION
 - FF SQUARE FEET
 - S.F. SQUARE GRADE BREAK
 - (TYP) TYPICAL MEASUREMENT
 - COLUMN TYPE

- NOTES**
1. ALL WALLS ARE PARALLEL, PERPENDICULAR OR AT 45 DEGREES TO THE BOUNDARY UNLESS SHOWN, UNLESS OTHERWISE NOTED.
 2. EXTERIOR THICKNESS SHOWN HEREIN REPRESENT THE DIMENSION FROM THAT APPLICABLE BOUNDARY LINE TO THE INTERIOR WALL SURFACE, UNLESS OTHERWISE NOTED.
 3. ALL PRIMARY UNIT DIMENSIONS SHOWN ARE TO THE FACE OF STUD OF THE WALL OR SURFACE OF CONCRETE WALLS AND COLUMNS.
 4. AREAS UNLABELED ARE GCE.
 5. FLOOR ELEVATION VALUES SEE FF AND S.G.B. GRADE BREAKS FOR LOCATIONS AND ELEVATIONS. SEE SHEET 47 FOR BENCHMARK.

SEE SHEET 11



SCALE: 1" = 10'

BLOCK 246, "CITY OF PORTLAND"
 TOGETHER WITH THE SOUTHERLY 30 FEET OF VACATED SW MADISON STREET,
 SITUATED IN THE NORTHEAST 1/4 OF SECTION 4, TOWNSHIP 1 SOUTH, RANGE 1 EAST,
 WILLAMETTE MERIDIAN, CITY OF PORTLAND, MULTNOMAH COUNTY, OREGON
 MARCH 7, 2006

SEE SHEET 10

SEE SHEET 10

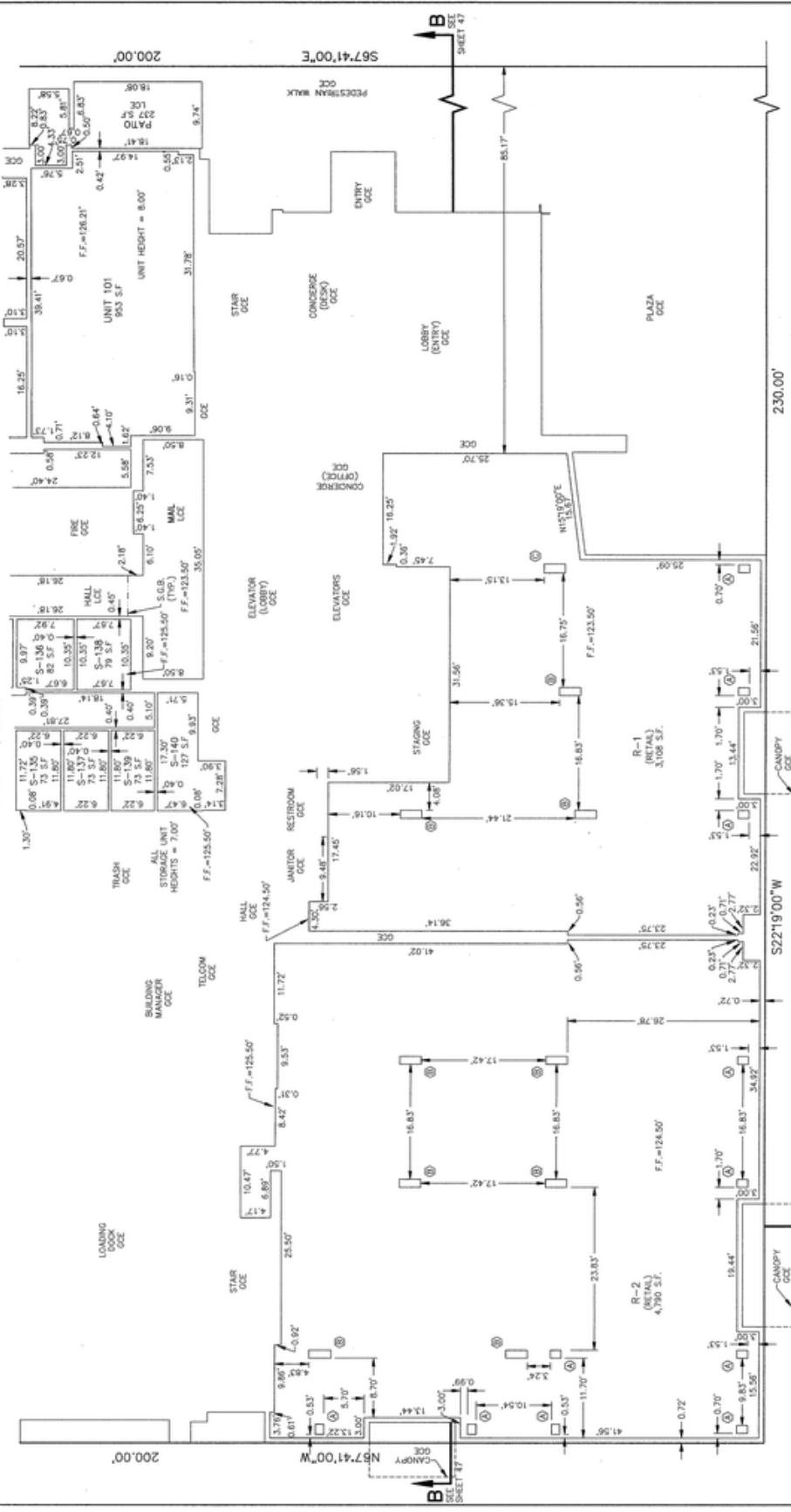

GROUND FLOOR—EAST

I HEREBY CERTIFY THIS TO BE A TRUE AND
 EXACT COPY OF THE ORIGINAL PLAT

GARY R. ANDERSON P.L.L.C. NO. 2434

SURVEYED BY:
WESTLAKE CONSULTANTS, INC.
 15115 S.W. SECONDA PARKWAY, SUITE 150
 TIGARD, OREGON 97224
 (503)684-0652

REGISTERED
 PROFESSIONAL
 LAND SURVEYOR

OREGON
 GARY R. ANDERSON
 2434

RENEWAL DATE
 12-31-07

LEGEND

UNIT-### PRIMARY UNIT (RESIDENTIAL)
 R-### STORAGE UNIT (RETAIL)
 S-### GENERAL COMMON ELEMENT
 LCE LIMITED COMMON ELEMENT
 FF FINISHED FLOOR ELEVATION
 S.G.B. SLAB GRADE BREAK
 (TYP.) TYPICAL MEASUREMENT
 ○ COLUMN TYPE

NOTES

1. ALL WALLS ARE PARALLEL, PERPENDICULAR OR AT 45 DEGREES TO THE BOUNDARY UNLESS SHOWN OTHERWISE NOTED.
2. EXTERIOR THICKNESS SHOWN HEREIN REPRESENT THE DIMENSION FROM THAT APPLICABLE BOUNDARY LINE TO THE INTERIOR WALL SURFACE, UNLESS OTHERWISE NOTED.
3. ALL PRIMARY UNIT DIMENSIONS SHOWN ARE TO THE FACE OF STUD OF THE WALL OR SURFACE OF CONCRETE WALLS AND COLUMNS.
4. AREAS UNLABELED ARE OCE.
5. FLOOR ELEVATION VARIES. SEE F.F. AND SLAB GRADE BREAKS FOR LOCATIONS AND ELEVATIONS. SEE SHEET 47 FOR BENCHMARK.

COLUMN TYPE DETAIL

1.05' x 1.05' OCE
 1.17' x 1.17' OCE
 1.35' x 1.35' OCE
 1.50' x 1.50' OCE
 1.65' x 1.65' OCE
 1.80' x 1.80' OCE

SCALE: 1" = 10'

ELIOT TOWER CONDOMINIUMS

BLOCK 246, "CITY OF PORTLAND"
TOGETHER WITH THE SOUTHERLY 30 FEET OF VACATED SW MADISON STREET,
SITUATED IN THE NORTHEAST 1/4 OF SECTION 4, TOWNSHIP 1 SOUTH, RANGE 1 EAST,
WILLAMETTE MERIDIAN, CITY OF PORTLAND, MULTNOMAH COUNTY, OREGON
MARCH 7, 2006

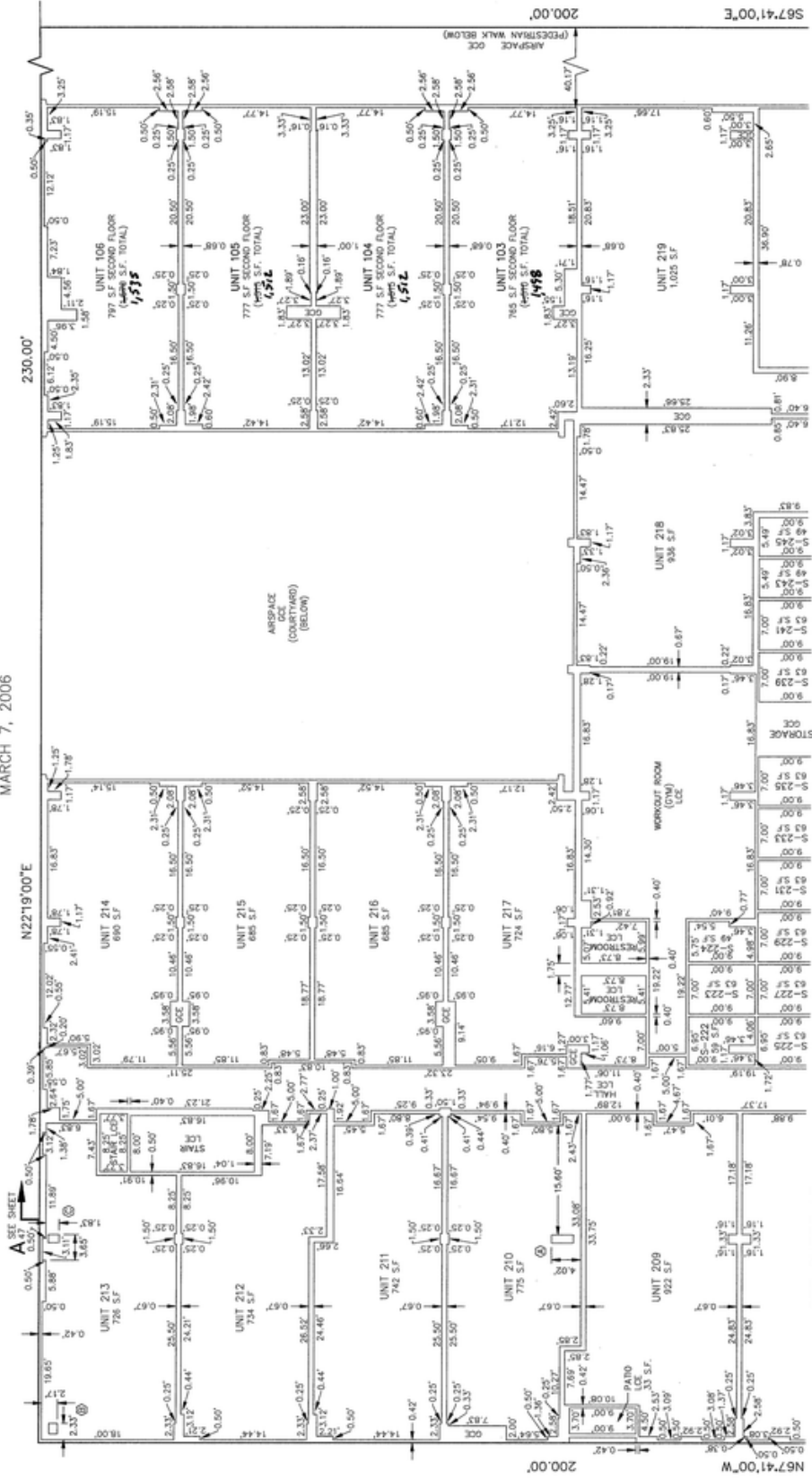

SEE SHEET 13

COLUMN TYPE DETAIL

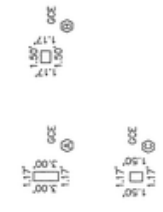

NOTES

1. ALL WALLS ARE PARALLEL, PERPENDICULAR OR AT 45 DEGREES TO THE BOUNDARY LINES SHOWN, UNLESS OTHERWISE NOTED.
2. EXTERIOR THICKNESS SHOWN HEREIN REPRESENT THE DIMENSION FROM THAT APPLICABLE BOUNDARY LINE TO THE INTERIOR WALL SURFACE, UNLESS OTHERWISE NOTED.
3. ALL PRIMARY UNIT DIMENSIONS SHOWN ARE TO THE FACE OF STUD OF THE WALL OR SURFACE OF CONCRETE WALLS AND COLUMNS.
4. AREAS UNLABELED ARE OCE.

LEGEND

- UNIT-### PRIMARY UNIT (RESIDENTIAL)
- S-### STORAGE UNIT (LCC)
- OCE GENERAL COMMON ELEMENT
- LCE LIMITED COMMON ELEMENT
- SF SQUARE FEET
- (TP) TYPICAL MEASUREMENT
- COLUMN TYPE

SEE SHEET 13

2ND FLOOR - WEST

I HEREBY CERTIFY THIS TO BE A TRUE AND EXACT COPY OF THE ORIGINAL PLAT

REGISTERED PROFESSIONAL LAND SURVEYOR
GARY R. ANDERSON
OREGON
JULY 25, 1990
26324

SURVEYED BY:
WESTLAKE CONSULTANTS, INC.
1035 S. WILSON PARKWAY, SUITE 150
TIGARD, OREGON 97224
(503)664-0652

RENEWAL DATE
12-31-07

ELIOT TOWER CONDOMINIUMS

BLOCK 246, "CITY OF PORTLAND"
 TOGETHER WITH THE SOUTHERLY 30 FEET OF VACATED SW MADISON STREET,
 SITUATED IN THE NORTHEAST 1/4 OF SECTION 4, TOWNSHIP 1 SOUTH, RANGE 1 EAST,
 WILLAMETTE MERIDIAN, CITY OF PORTLAND, MULTNOMAH COUNTY, OREGON
 MARCH 7, 2006

SEE SHEET 12

SEE SHEET 12

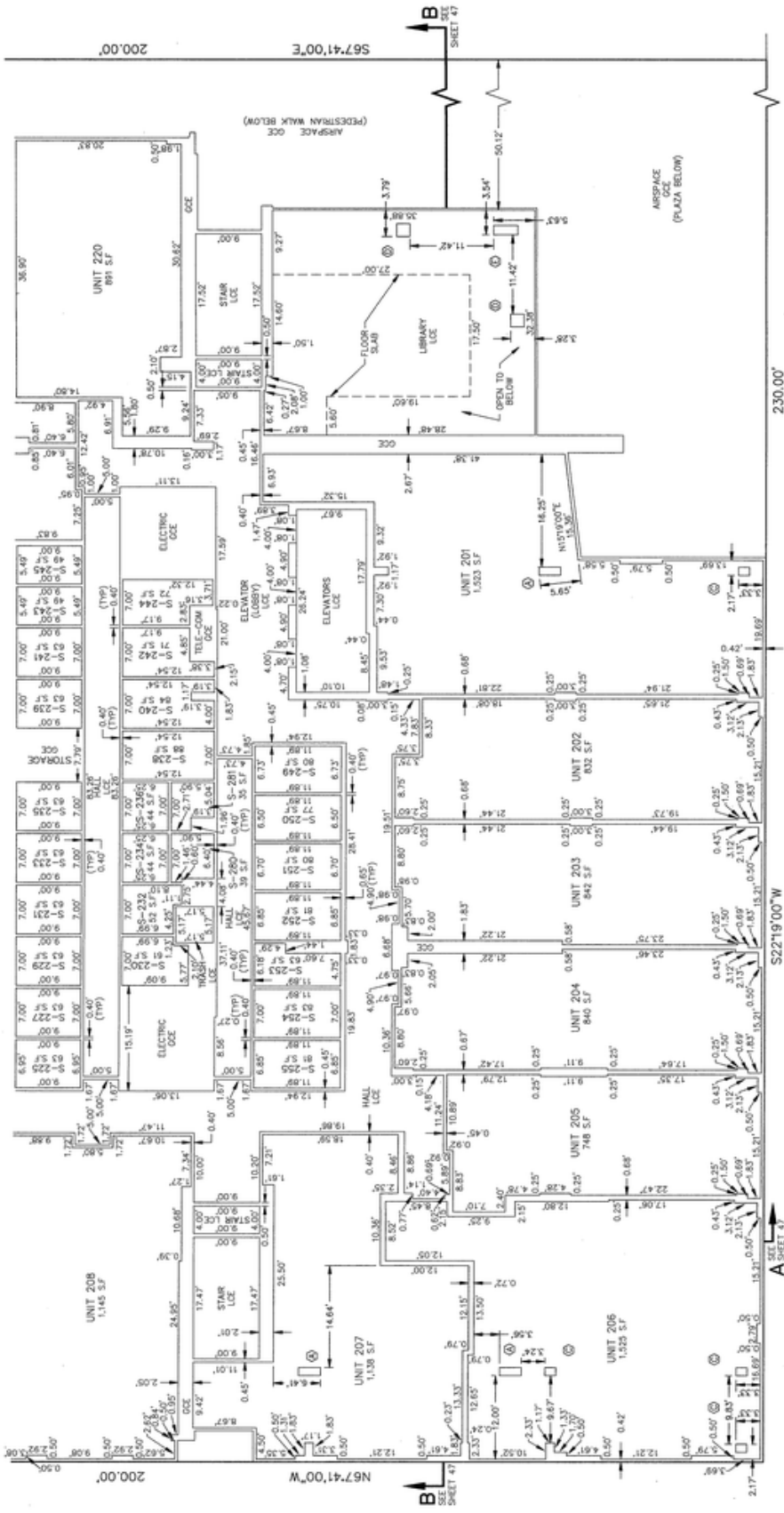

2ND FLOOR--EAST

I HEREBY CERTIFY THIS TO BE A TRUE AND
 EXACT COPY OF THE ORIGINAL PLAN
 GARY R. ANDERSON P.L.E. NO. 2434

REGISTERED
 PROFESSIONAL
 LAND SURVEYOR
 GARY R. ANDERSON
 OREGON
 2434

SURVEYED BY:
WESTLAKE CONSULTANTS, INC.
 15115 S.W. SCULOGA PARKWAY, SUITE 150
 TIGARD, OREGON 97224
 (503)684-0652

RENEWAL DATE
 12-31-07

1042-08(B) SHEET 13 OF 48

LEGEND

- UNIT-### PRIMARY UNIT (RESIDENTIAL)
- S-### STORAGE UNIT (LCL)
- CEZ GENERAL COMMON ELEMENT
- LCE LIMITED COMMON ELEMENT
- (TPP-) SQUARE FEET SURROUNDMENT
- (O) COLUMN TYPE

NOTES

1. ALL WALLS ARE PARALLEL, PERPENDICULAR OR AT 45 DEGREES TO THE BOUNDARY LINES SHOWN, UNLESS OTHERWISE NOTED.
2. EXTERIOR THICKNESS SHOWN HEREIN REPRESENT THE DIMENSION FROM FINISH FACE TO FINISH FACE OF THE BOUNDARY LINE TO THE INTERIOR WALL SURFACE, UNLESS OTHERWISE NOTED.
3. ALL DIMENSIONED DIMENSIONS SHOWN ARE TO THE FACE OF STUD OF THE WALL OR SURFACE OF CONCRETE WALLS AND COLUMNS.
4. AREAS UNLABELED ARE OCE.

COLUMN TYPE DETAIL

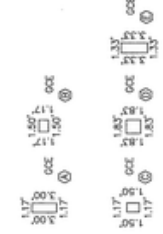

SCALE: 1" = 10'

ELIOT TOWER CONDOMINIUMS

BLOCK 246, "CITY OF PORTLAND"
 TOGETHER WITH THE SOUTHERLY 30 FEET OF VACATED SW MADISON STREET,
 SITUATED IN THE NORTHEAST 1/4 OF SECTION 4, TOWNSHIP 1 SOUTH, RANGE 1 EAST,
 WILLAMETTE MERIDIAN, CITY OF PORTLAND, MULTNOMAH COUNTY, OREGON
 MARCH 7, 2006

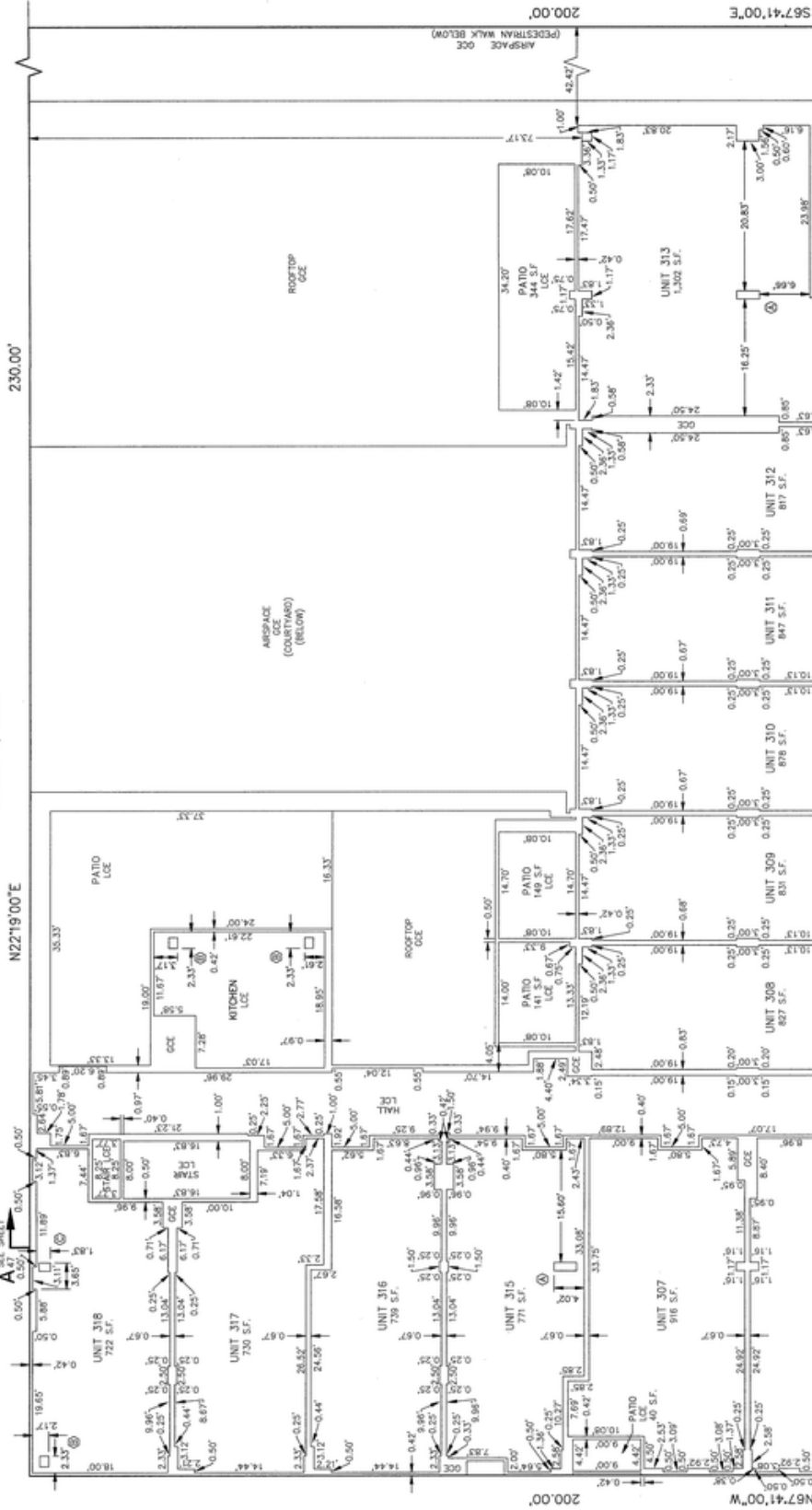

SEE SHEET 15

SEE SHEET 14

3RD FLOOR—WEST

I HEREBY CERTIFY THIS TO BE A TRUE AND
 EXACT COPY OF THE ORIGINAL PLAT
 GARY R. ANDERSON P.L.S. NO. 2404

REGISTERED
 PROFESSIONAL
 LAND SURVEYOR
 OREGON
 2737 SW 109th
 GARY R. ANDERSON
 97224

SURVEYED BY:
 WESTLAKE CONSULTANTS, INC.
 1015 S. GREGORY AVENUE, SUITE 150
 TIGARD, OREGON 97224
 (503)664-0662

LEGEND

- UNIT-### PRIMARY UNIT (RESIDENTIAL)
- OCCE GENERAL COMMON ELEMENT
- S.F. SQUARE FEET
- COLUMN TYPE

NOTES

1. ALL WALLS ARE PARALLEL, PERPENDICULAR OR AT 45 DEGREES TO THE BOUNDARY LINES SHOWN, UNLESS OTHERWISE NOTED.
2. EXTERIOR THICKNESS SHOWN HEREON REPRESENT THE DIMENSION FROM THAT APPLICABLE BOUNDARY LINE TO THE INTERIOR WALL SURFACE, UNLESS OTHERWISE NOTED.
3. ALL PRIMARY UNIT DIMENSIONS SHOWN ARE TO THE FACE OF STUD OF THE WALL, OR SURFACE OF CONCRETE WALLS AND COLUMNS.
4. AREAS UNLABELED ARE OCCE.

COLUMN TYPE DETAIL



SCALE: 1" = 10'

ELIOT TOWER CONDOMINIUMS

BLOCK 246, "CITY OF PORTLAND"
 TOGETHER WITH THE SOUTHERLY 30 FEET OF VACATED SW MADISON STREET,
 SITUATED IN THE NORTHEAST 1/4 OF SECTION 4, TOWNSHIP 1 SOUTH, RANGE 1 EAST,
 WILLAMETTE MERIDIAN, CITY OF PORTLAND, MULTNOMAH COUNTY, OREGON
 MARCH 7, 2006

SEE SHEET 14

SEE SHEET 14

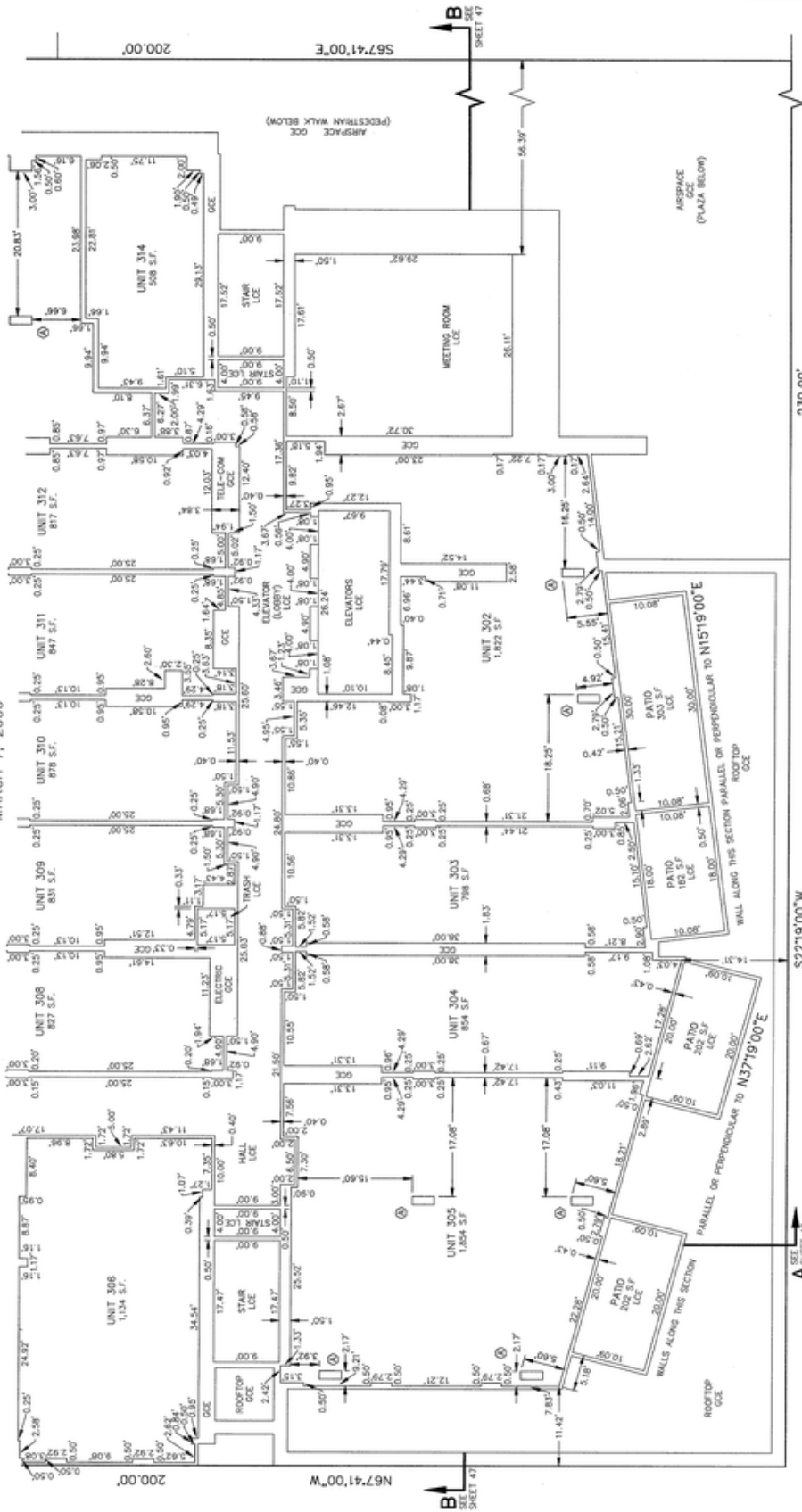

COLUMN TYPE DETAIL

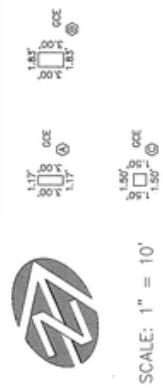

SCALE: 1" = 10'

NOTES

1. ALL WALLS ARE PARALLEL, PERPENDICULAR OR AT 45 DEGREES TO THE BOUNDARY LINES SHOWN, UNLESS OTHERWISE NOTED.
2. EXTERIOR THICKNESS SHOWN HEREIN REPRESENT THE DIMENSION FROM THAT APPLICABLE BOUNDARY LINE TO THE INTERIOR WALL SURFACE, UNLESS OTHERWISE NOTED.
3. ALL PRIMARY UNIT DIMENSIONS SHOWN ARE TO THE FACE OF STILD OF THE WALL, OR SURFACE OF CONCRETE WALLS AND COLUMNS.
4. AREAS UNLABELED ARE OCE.

LEGEND

- UNIT-## PRIMARY UNIT (RESIDENTIAL)
- OCE GENERAL COMMON ELEMENT
- LCE LIMITED COMMON ELEMENT
- S.F. SQUARE FEET
- COLUMN TYPE

3RD FLOOR-EAST

I HEREBY CERTIFY THIS TO BE A TRUE AND EXACT COPY OF THE ORIGINAL PLAT
 GARY R. ANDERSON P.L.S. NO. 2434

REGISTERED PROFESSIONAL LAND SURVEYOR
 GARY R. ANDERSON
 2538

SURVEYED BY:
 WESTLAKE CONSULTANTS, INC.
 15115 S.W. SEQUOIA PARKWAY, SUITE 150
 TIGARD, OREGON 97224
 (503)864-0652

12-31-07
 RENEWAL DATE

SHEET 15 OF 48

ELIOT TOWER CONDOMINIUMS

BLOCK 246, "CITY OF PORTLAND"
 TOGETHER WITH THE SOUTHERLY 30 FEET OF VACATED SW MADISON STREET,
 SITUATED IN THE NORTHEAST 1/4 OF SECTION 4, TOWNSHIP 1 SOUTH, RANGE 1 EAST,
 WILLAMETTE MERIDIAN, CITY OF PORTLAND, MULTNOMAH COUNTY, OREGON
 MARCH 7, 2006

SEE SHEET 16

SEE SHEET 16

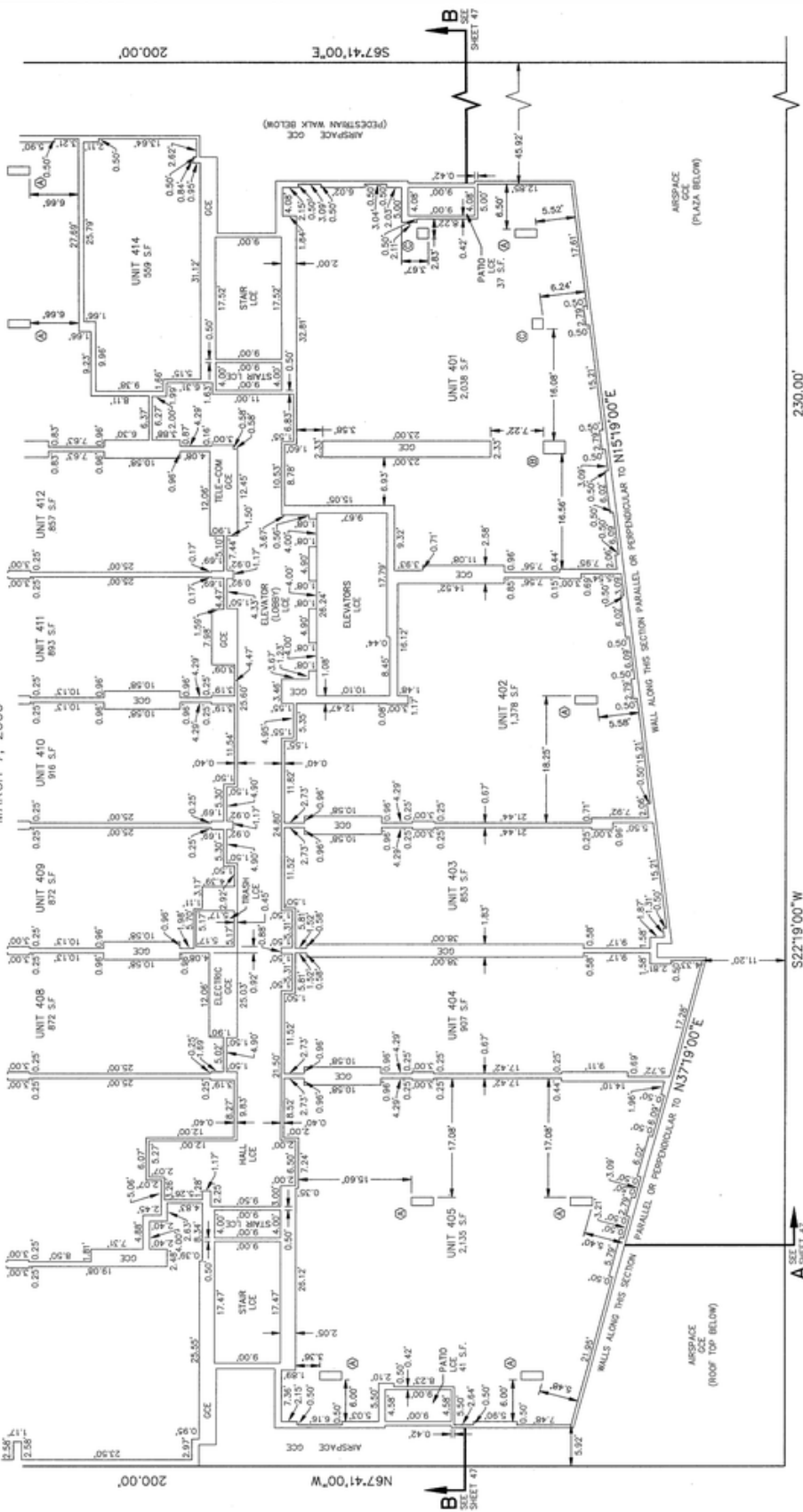

COLUMN TYPE DETAIL



SCALE: 1" = 10'

NOTES

1. ALL WALLS ARE PARALLEL, PERPENDICULAR OR AT 45 DEGREES TO THE BOUNDARY LINES SHOWN, UNLESS OTHERWISE NOTED.
2. EXTERIOR THICKNESS SHOWN HEREIN REPRESENT THE DIMENSION FROM THAT APPLICABLE BOUNDARY LINE TO THE INTERIOR WALL SURFACE, UNLESS OTHERWISE NOTED.
3. ALL PRIMARY UNIT DIMENSIONS SHOWN ARE TO THE FACE OF STUD OF THE WALL OR SURFACE OF CONCRETE WALLS AND COLUMNS.
4. AREAS UNLABELED ARE OCE.

LEGEND

- UNIT-## PRIMARY UNIT (RESIDENTIAL)
- OCE GENERAL COMMON ELEMENT
- SF SQUARE FEET
- COLUMN TYPE

REGISTERED PROFESSIONAL LAND SURVEYOR
 GARY R. ANDERSON
 OREGON
 JULY 25, 1995
 GARY R. ANDERSON
 2632

4TH FLOOR-EAST

I HEREBY CERTIFY THIS TO BE A TRUE AND EXACT COPY OF THE ORIGINAL PLAT

GARY R. ANDERSON P.L.S. NO. 2434

SURVEYED BY:
 WESTLAKE CONSULTANTS, INC.
 1105 S. WASHINGTON AVENUE, SUITE 150
 TIGARD, OREGON 97224
 (503)664-0662

REVISION DATE
 12-31-07

SHEET 17 OF 48

104208FD4.DWG

ELIOT TOWER CONDOMINIUMS

BLOCK 246, "CITY OF PORTLAND"
 TOGETHER WITH THE SOUTHERLY 30 FEET OF VACATED SW MADISON STREET,
 SITUATED IN THE NORTHEAST 1/4 OF SECTION 4, TOWNSHIP 1 SOUTH, RANGE 1 EAST,
 WILLAMETTE MERIDIAN, CITY OF PORTLAND, MULTNOMAH COUNTY, OREGON
 MARCH 7, 2006

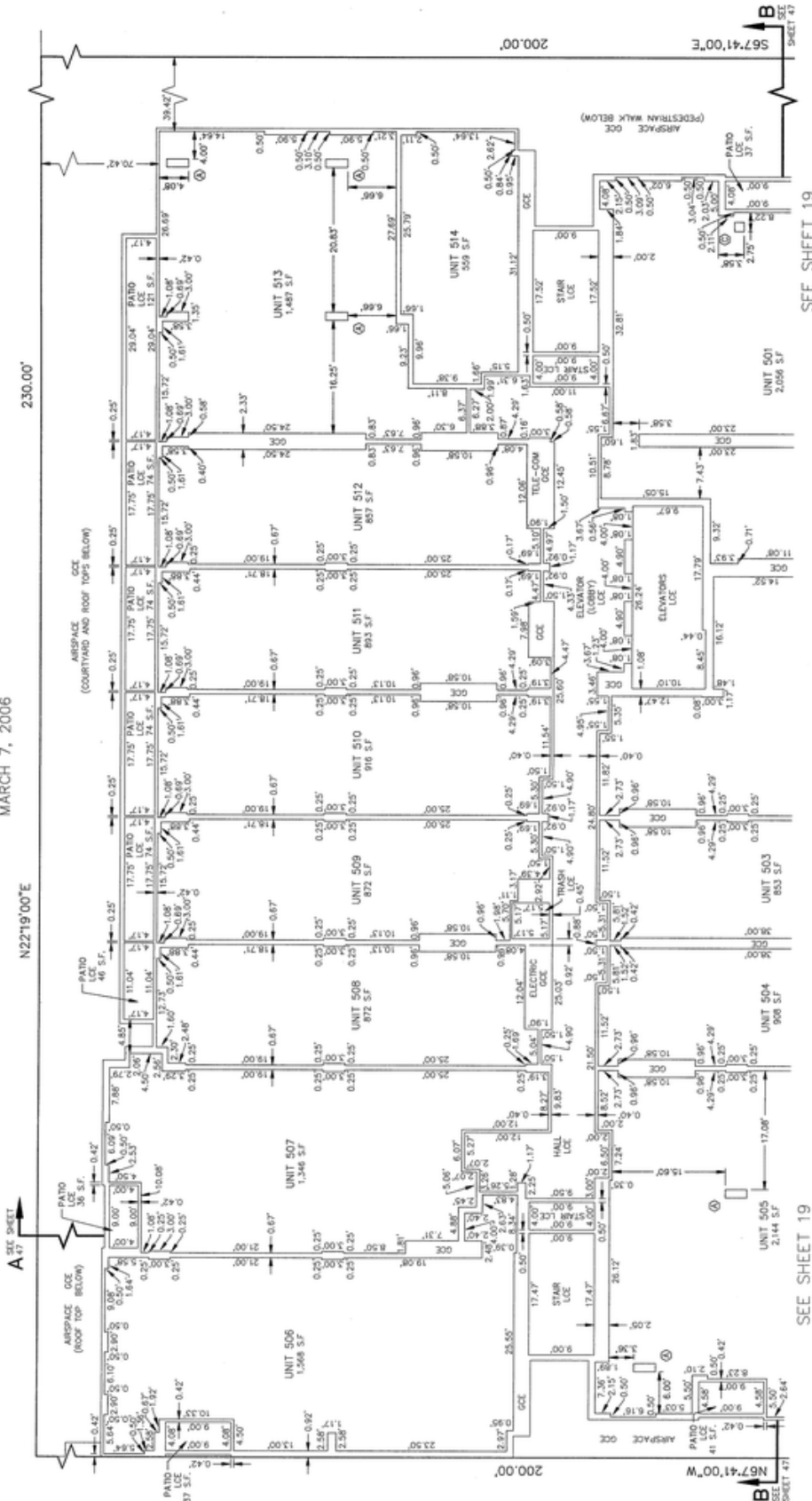

SEE SHEET 19

SEE SHEET 19

SEE SHEET 19

SEE SHEET 19

SEE SHEET 19

SEE SHEET 19

5TH FLOOR - WEST
 I HEREBY CERTIFY THIS TO BE A TRUE AND
 EXACT COPY OF THE ORIGINAL PLAT
 GARY R. ANDERSON P.L.S. NO. 2434

REGISTERED
 PROFESSIONAL
 LAND SURVEYOR
 GARY R. ANDERSON
 JULY 25, 1990
 2434

LEGEND
 UNIT-## PRIMARY UNIT (RESIDENTIAL)
 GCE GENERAL COMMON ELEMENT
 LCE LIMITED COMMON ELEMENT
 SF SQUARE FEET
 O COLUMN TYPE

NOTES
 1. ALL WALLS ARE PARALLEL, PERPENDICULAR OR AT 45 DEGREES TO THE
 BOUNDARY LINES SHOWN, UNLESS OTHERWISE NOTED.
 2. EXTERIOR THICKNESS SHOWN HEREON REPRESENT THE DIMENSION FROM
 THAT APPLICABLE BOUNDARY LINE TO THE INTERIOR WALL SURFACE, UNLESS
 OTHERWISE NOTED.
 3. ALL PRIMARY UNIT DIMENSIONS SHOWN ARE TO THE FACE OF STILD OF
 THE WALL, OR SURFACE OF CONCRETE WALLS AND COLUMNS.
 4. AREAS UNLABELED ARE GCE.



SCALE: 1" = 10'
 1.17' GCE
 1.17' LCE
 1.17' SF
 1.17' O

104208F05.DWG

ELIOT TOWER CONDOMINIUMS

BLOCK 246, "CITY OF PORTLAND"
TOGETHER WITH THE SOUTHERLY 30 FEET OF VACATED SW MADISON STREET,
SITUATED IN THE NORTHEAST 1/4 OF SECTION 4, TOWNSHIP 1 SOUTH, RANGE 1 EAST,
WILLAMETTE MERIDIAN, CITY OF PORTLAND, MULTNOMAH COUNTY, OREGON
MARCH 7, 2006

SEE SHEET 18

SEE SHEET 18

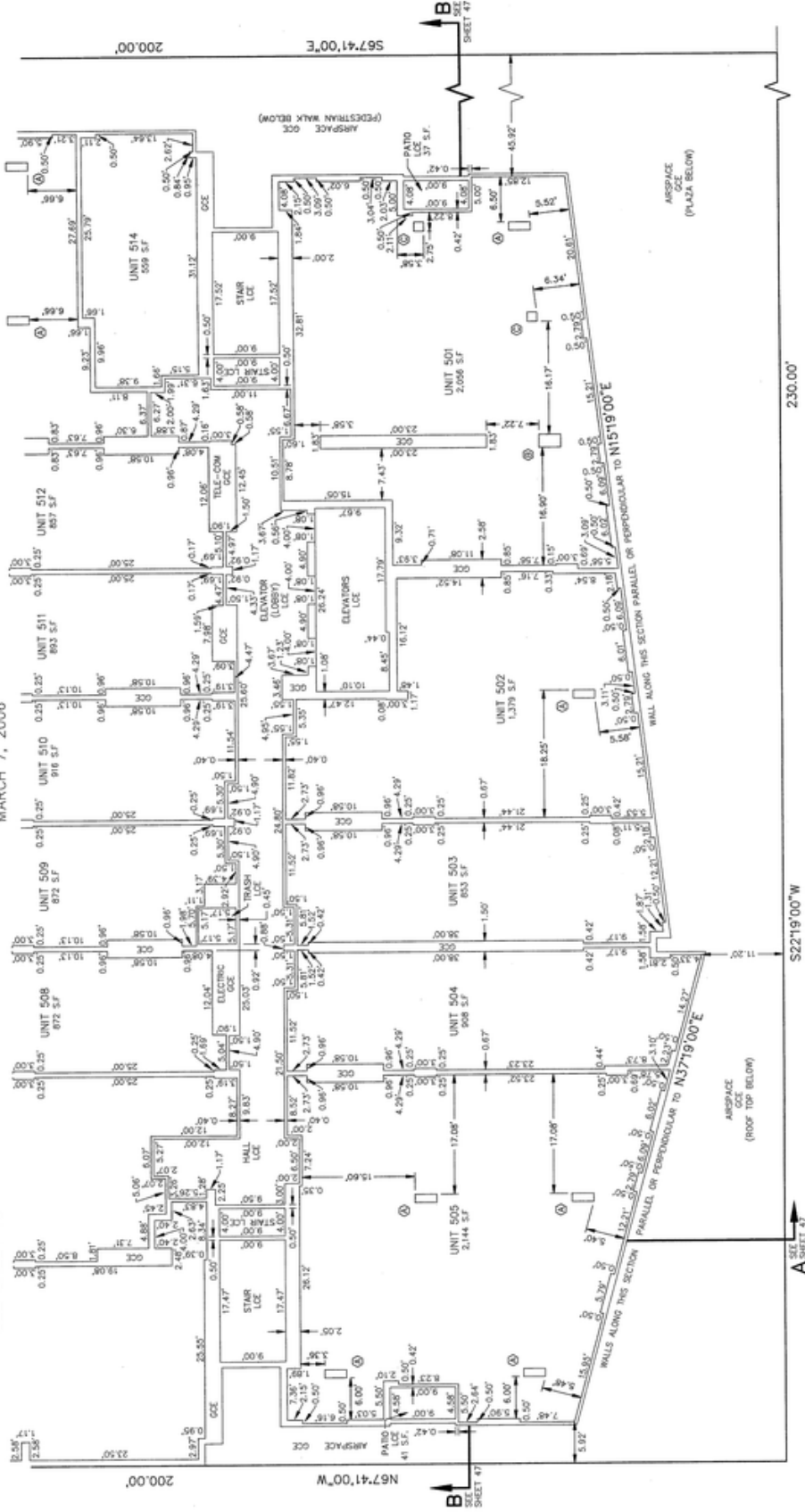

5TH FLOOR-EAST

I HEREBY CERTIFY THIS TO BE A TRUE AND EXACT COPY OF THE ORIGINAL PLAT

REGISTERED PROFESSIONAL LAND SURVEYOR

GARY R. ANDERSON P.L.S. NO. 2434

SURVEYED BY:
WESTLAKE CONSULTANTS, INC.
15115 S.W. SEQUOIA PARKWAY, SUITE 150
TIGARD, OREGON 97224
(503)864-0652

LEGEND

- UNIT-## PRIMARY UNIT (RESIDENTIAL)
- GENERAL COMMON ELEMENT
- LCE LIMITED COMMON ELEMENT
- SF SQUARE FEET
- COLUMN TYPE

NOTES

1. ALL WALLS ARE PARALLEL, PERPENDICULAR OR AT 45 DEGREES TO THE BOUNDARY LINES SHOWN, UNLESS OTHERWISE NOTED.
2. EXTERIOR THICKNESS SHOWN HEREON REPRESENT THE DIMENSION FROM THAT APPLICABLE BOUNDARY LINE TO THE INTERIOR WALL SURFACE, UNLESS OTHERWISE NOTED.
3. ALL PRIMARY UNIT DIMENSIONS SHOWN ARE TO THE FACE OF STUD OF THE WALL OR SURFACE OF CONCRETE WALLS AND COLUMNS.
4. AREAS UNLABELED ARE GCE.

COLUMN TYPE DETAIL

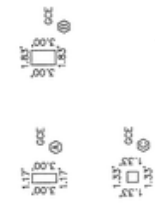

SCALE: 1" = 10'

RENEWAL DATE 12-31-07

1042-08(B)

SHEET 19 OF 48

104208F05.DWG

ELIOT TOWER CONDOMINIUMS

BLOCK 246, "CITY OF PORTLAND"
 TOGETHER WITH THE SOUTHERLY 30 FEET OF VACATED SW MADISON STREET,
 SITUATED IN THE NORTHEAST 1/4 OF SECTION 4, TOWNSHIP 1 SOUTH, RANGE 1 EAST,
 WILLAMETTE MERIDIAN, CITY OF PORTLAND, MULTNOMAH COUNTY, OREGON
 MARCH 7, 2006

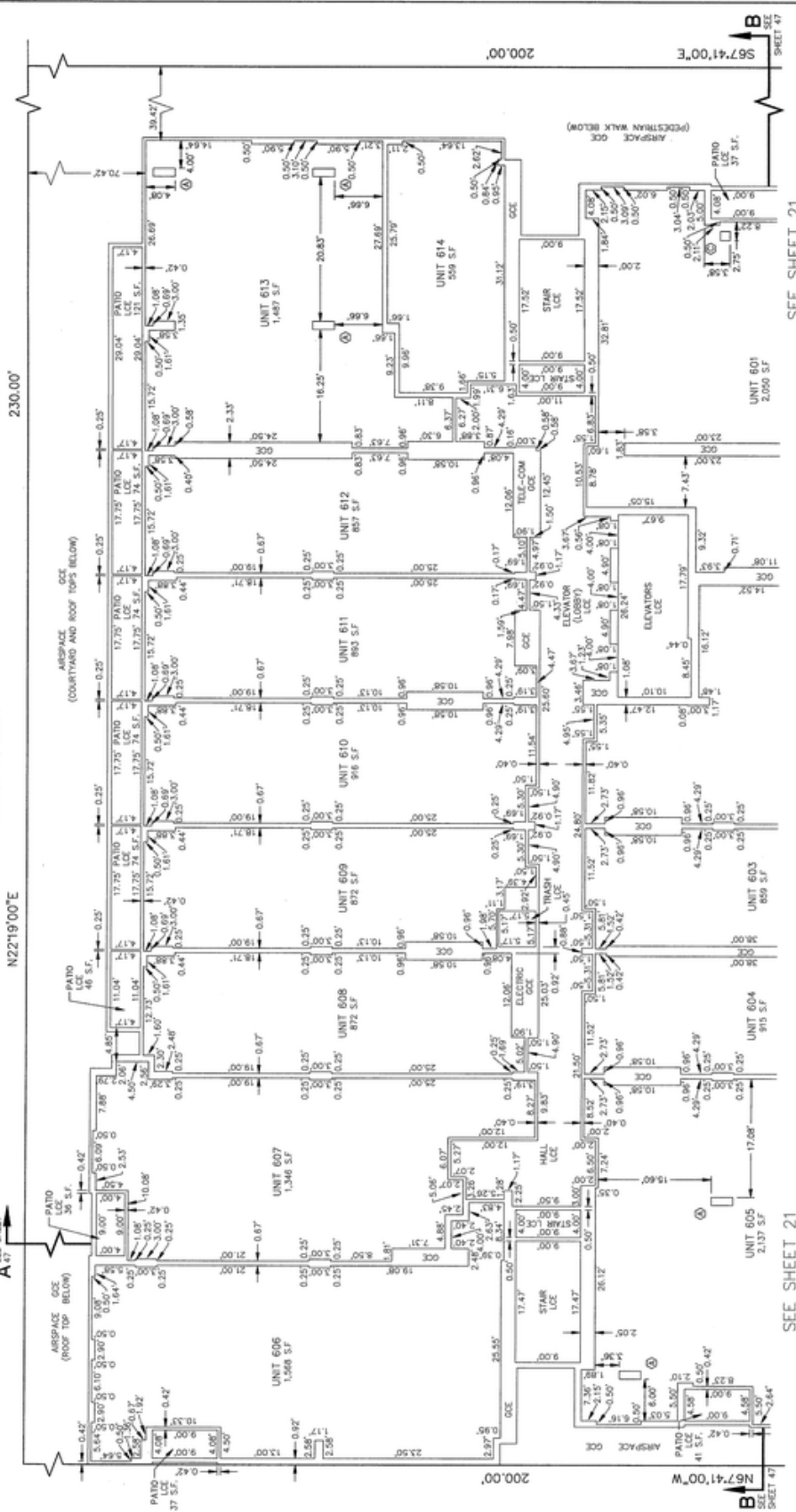

6TH FLOOR—WEST
 I HEREBY CERTIFY THIS TO BE A TRUE AND EXACT COPY OF THE ORIGINAL PLAT
 GARY R. ANDERSON P.L.S. NO. 2434

REGISTERED PROFESSIONAL LAND SURVEYOR
 GARY R. ANDERSON
 JUNE 20, 1990
 2434

LEGEND
 UNIT ## (RESIDENTIAL)
 LCE COMMON ELEMENT
 LCE LIMITED COMMON ELEMENT
 SF SQUARE FEET
 C COLUMN TYPE

NOTES
 1. ALL WALLS ARE PARALLEL, PERPENDICULAR OR AT 45 DEGREES TO THE BOUNDARY LINES SHOWN, UNLESS OTHERWISE NOTED.
 2. EXTERIOR THICKNESS SHOWN HEREON REPRESENTS THE DIMENSION FROM THAT APPLICABLE BOUNDARY LINE TO THE INTERIOR WALL SURFACE, UNLESS OTHERWISE NOTED.
 3. ALL PRIMARY DIMENSIONS SHOWN ARE TO THE FACE OF SILD OF THE WALL OR SURFACE OF CONCRETE WALLS AND COLUMNS.
 4. AREAS UNLABELED ARE GCE.

SEE SHEET 21

SCALE: 1" = 10'

SURVEYED BY:
 WESTLAKE CONSULTANTS, INC.
 1515 S.W. SEQUOIA PARKWAY, SUITE 150
 TIGARD, OREGON 97224
 (503)884-0652

RENEWAL DATE:
 12-31-07

1042-08(B)

SEE SHEET 21

SEE SHEET 21

SEE SHEET 21

10420806.DWG

ELIOT TOWER CONDOMINIUMS

BLOCK 246, "CITY OF PORTLAND"
 TOGETHER WITH THE SOUTHERLY 30 FEET OF VACATED SW MADISON STREET,
 SITUATED IN THE NORTHEAST 1/4 OF SECTION 4, TOWNSHIP 1 SOUTH, RANGE 1 EAST,
 WILLAMETTE MERIDIAN, CITY OF PORTLAND, MULTNOMAH COUNTY, OREGON
 MARCH 7, 2006

SEE SHEET 20

SEE SHEET 20

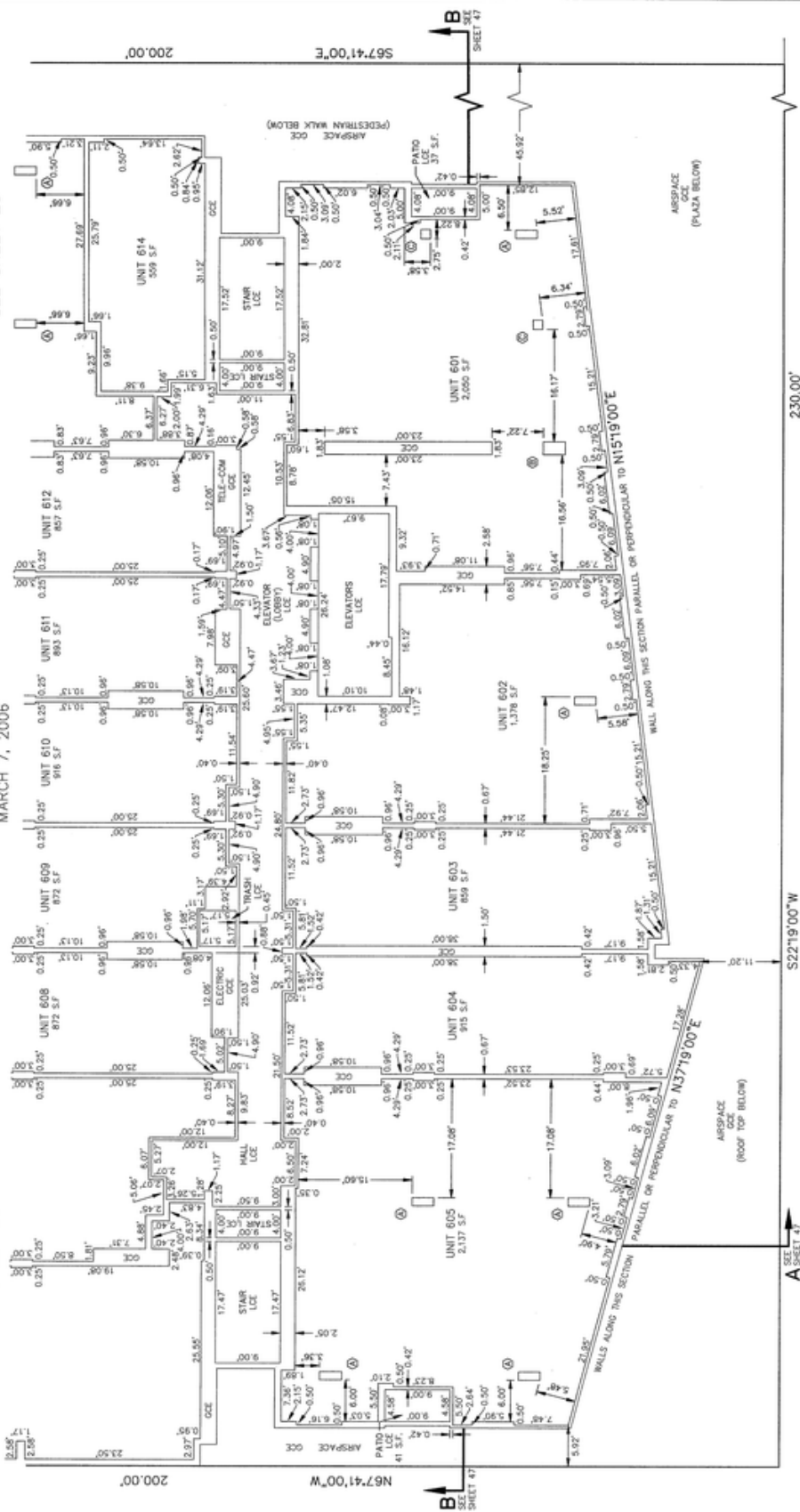

6TH FLOOR-EAST

I HEREBY CERTIFY THIS TO BE A TRUE AND EXACT COPY OF THE ORIGINAL PLAT
 GARY R. ANDERSON P.L.S. NO. 2434



SURVEYED BY:
 WESTLAKE CONSULTANTS, INC.
 15115 S.W. SEQUOIA PARKWAY, SUITE 150
 TIGARD, OREGON 97224
 (503)864-0652

1042-08(B) SHEET 21 OF 48

LEGEND

- UNIT ## PRIMARY UNIT (RESIDENTIAL)
- CEILING COMMON ELEMENT
- LOZ LIMITED COMMON ELEMENT
- S.F. SQUARE FEET
- COLUMN TYPE

NOTES

1. ALL WALLS ARE PARALLEL, PERPENDICULAR OR AT 45 DEGREES TO THE BOUNDARY LINES SHOWN, UNLESS OTHERWISE NOTED.
2. EXTERIOR THICKNESS SHOWN HEREON REPRESENT THE DIMENSION FROM THAT APPLICABLE BOUNDARY LINE TO THE INTERIOR WALL SURFACE, UNLESS OTHERWISE NOTED.
3. ALL PRIMARY UNIT DIMENSIONS SHOWN ARE TO THE FACE OF STUD OF THE WALL, OR SURFACE OF CONCRETE WALLS AND COLUMNS.
4. AREAS UNLABELED ARE G.C.E.

COLUMN TYPE DETAIL

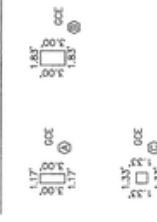

SCALE: 1" = 10'

BLOCK 246, "CITY OF PORTLAND"
 TOGETHER WITH THE SOUTHERLY 30 FEET OF VACATED SW MADISON STREET,
 SITUATED IN THE NORTHEAST 1/4 OF SECTION 4, TOWNSHIP 1 SOUTH, RANGE 1 EAST,
 WILLAMETTE MERIDIAN, CITY OF PORTLAND, MULTNOMAH COUNTY, OREGON
 MARCH 7, 2006

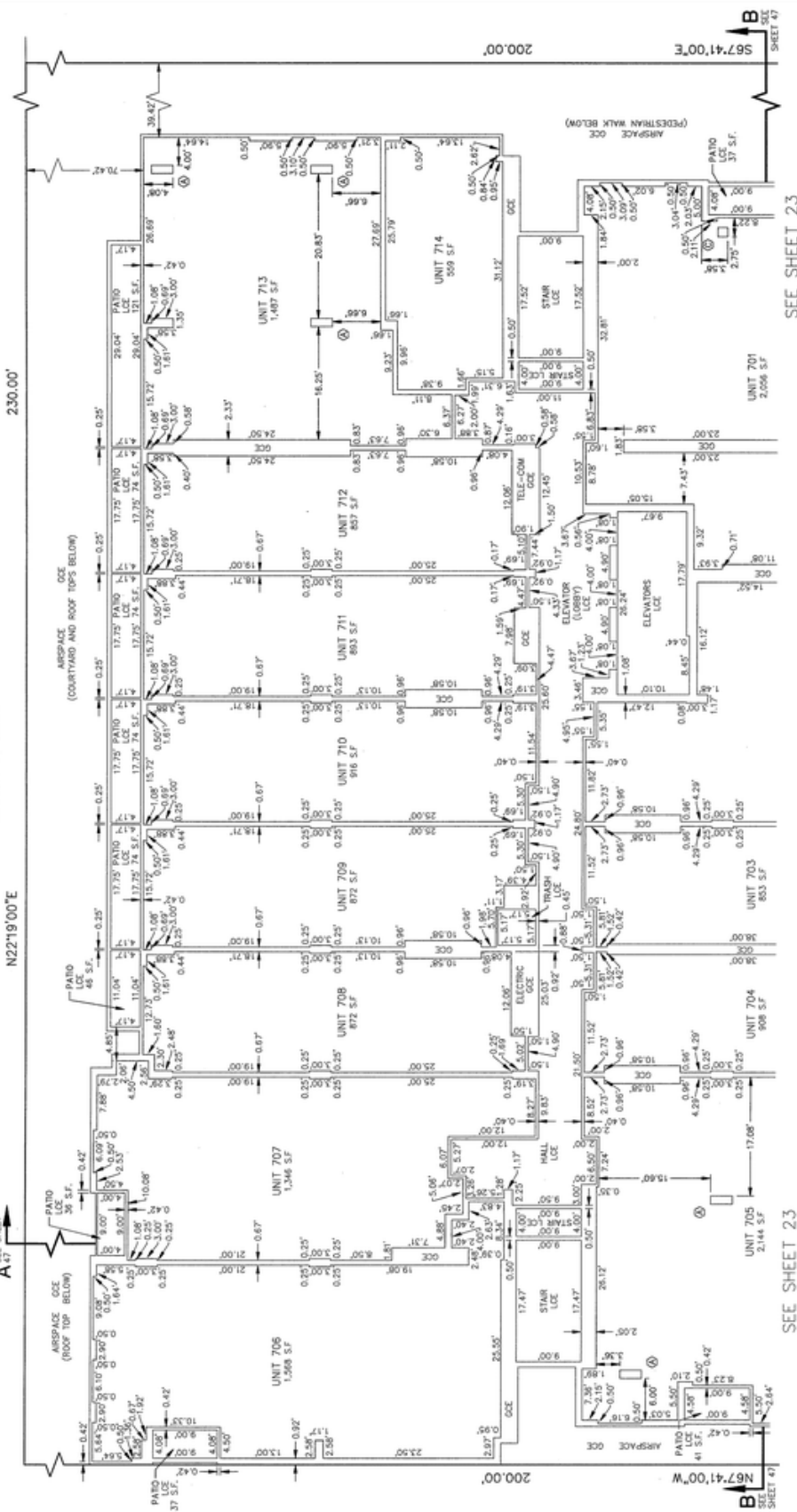

7TH FLOOR—WEST
 I HEREBY CERTIFY THIS TO BE A TRUE AND
 EXACT COPY OF THE ORIGINAL PLAT
 GARY R. ANDERSON P.L.S. NO. 2434
 SURVEYED BY:
 WESTLAKE CONSULTANTS, INC.
 15115 S.W. SEQUOIA PARKWAY, SUITE 150
 TIGARD, OREGON 97224
 (503)864-0852

REGISTERED
 PROFESSIONAL
 LAND SURVEYOR
 GARY R. ANDERSON
 JULY 24, 1990
 OREGON
 2434

LEGEND
 UNIT-## PRIMARY UNIT (RESIDENTIAL)
 OCE GENERAL COMMON ELEMENT
 LCE LIMITED COMMON ELEMENT
 SF SQUARE FEET
 C COLUMN TYPE

NOTES
 1. ALL WALLS ARE PARALLEL, PERPENDICULAR OR AT 45 DEGREES TO THE
 BOUNDARY LINES SHOWN, UNLESS OTHERWISE NOTED.
 2. EXTERIOR THICKNESS SHOWN HEREON REPRESENT THE DIMENSION FROM
 THAT APPLICABLE BOUNDARY LINE TO THE INTERIOR WALL SURFACE, UNLESS
 OTHERWISE NOTED.
 3. ALL PRIMARY UNIT DIMENSIONS SHOWN ARE TO THE FACE OF STUD OF
 THE WALL OR SURFACE OF CONCRETE WALLS AND COLUMNS.
 4. AREAS UNLABELED ARE OCE.

COLUMN TYPE DETAIL
 1.17' OCE
 1.17' C
 1.17' OCE
 1.33' OCE
 1.33' C
 1.33' OCE

SCALE: 1" = 10'
 104208F07.DWG

ELIOT TOWER CONDOMINIUMS

BLOCK 246, "CITY OF PORTLAND"
 TOGETHER WITH THE SOUTHERLY 30 FEET OF VACATED SW MADISON STREET,
 SITUATED IN THE NORTHEAST 1/4 OF SECTION 4, TOWNSHIP 1 SOUTH, RANGE 1 EAST,
 WILLAMETTE MERIDIAN, CITY OF PORTLAND, MULTNOMAH COUNTY, OREGON
 MARCH 7, 2006

SEE SHEET 22

SEE SHEET 22

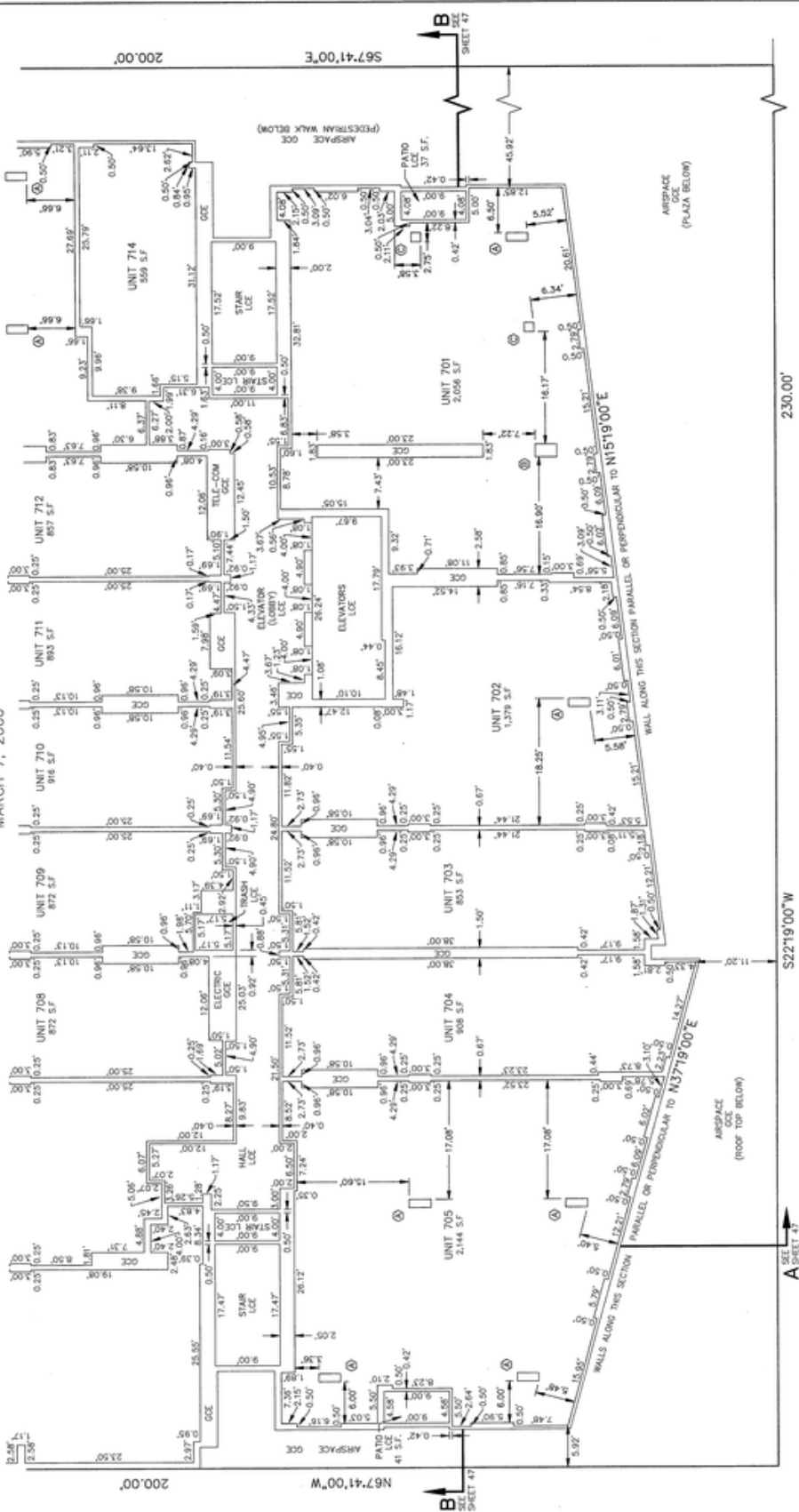

7TH FLOOR—EAST

I HEREBY CERTIFY THIS TO BE A TRUE AND
 CORRECT COPY OF THE ORIGINAL PLAT

GARY R. ANDERSON P.L.S. NO. 2404

SURVEYED BY:
 WESTLAKE CONSULTANTS, INC.
 15115 S.W. SECURIA PARKWAY, SUITE 150
 TIGARD, OREGON 97224
 (503)684-0652

SHEET 23 OF 48
 1042-08(B)

REGISTERED
 PROFESSIONAL
 LAND SURVEYOR

GARY R. ANDERSON
 P.L.S. NO. 2404

RENEWAL DATE
 12-31-07

LEGEND

- UNIT-## PRIMARY UNIT (RESIDENTIAL)
- GOE GENERAL COMMON ELEMENT
- LCE LIMITED COMMON ELEMENT
- SF SQUARE FEET
- COLUMN TYPE

NOTES

1. ALL WALLS ARE PARALLEL, PERPENDICULAR OR AT 45 DEGREES TO THE BOUNDARY LINES SHOWN, UNLESS OTHERWISE NOTED.
2. EXTERIOR THICKNESS SHOWN HEREIN REPRESENT THE DIMENSION FROM THAT APPLICABLE BOUNDARY LINE TO THE INTERIOR WALL SURFACE, UNLESS OTHERWISE NOTED.
3. ALL PRIMARY UNIT DIMENSIONS SHOWN ARE TO THE FACE OF STUDO OF THE WALL OR SURFACE OF CONCRETE WALLS AND COLUMNS.
4. AREAS UNLABELED ARE GOE.

COLUMN TYPE DETAIL

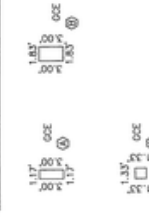

SCALE: 1" = 10'

ELIOT TOWER CONDOMINIUMS

BLOCK 246, "CITY OF PORTLAND"
 TOGETHER WITH THE SOUTHERLY 30 FEET OF VACATED SW MADISON STREET,
 SITUATED IN THE NORTHEAST 1/4 OF SECTION 4, TOWNSHIP 1 SOUTH, RANGE 1 EAST,
 WILLAMETTE MERIDIAN, CITY OF PORTLAND, MULTNOMAH COUNTY, OREGON
 MARCH 7, 2006

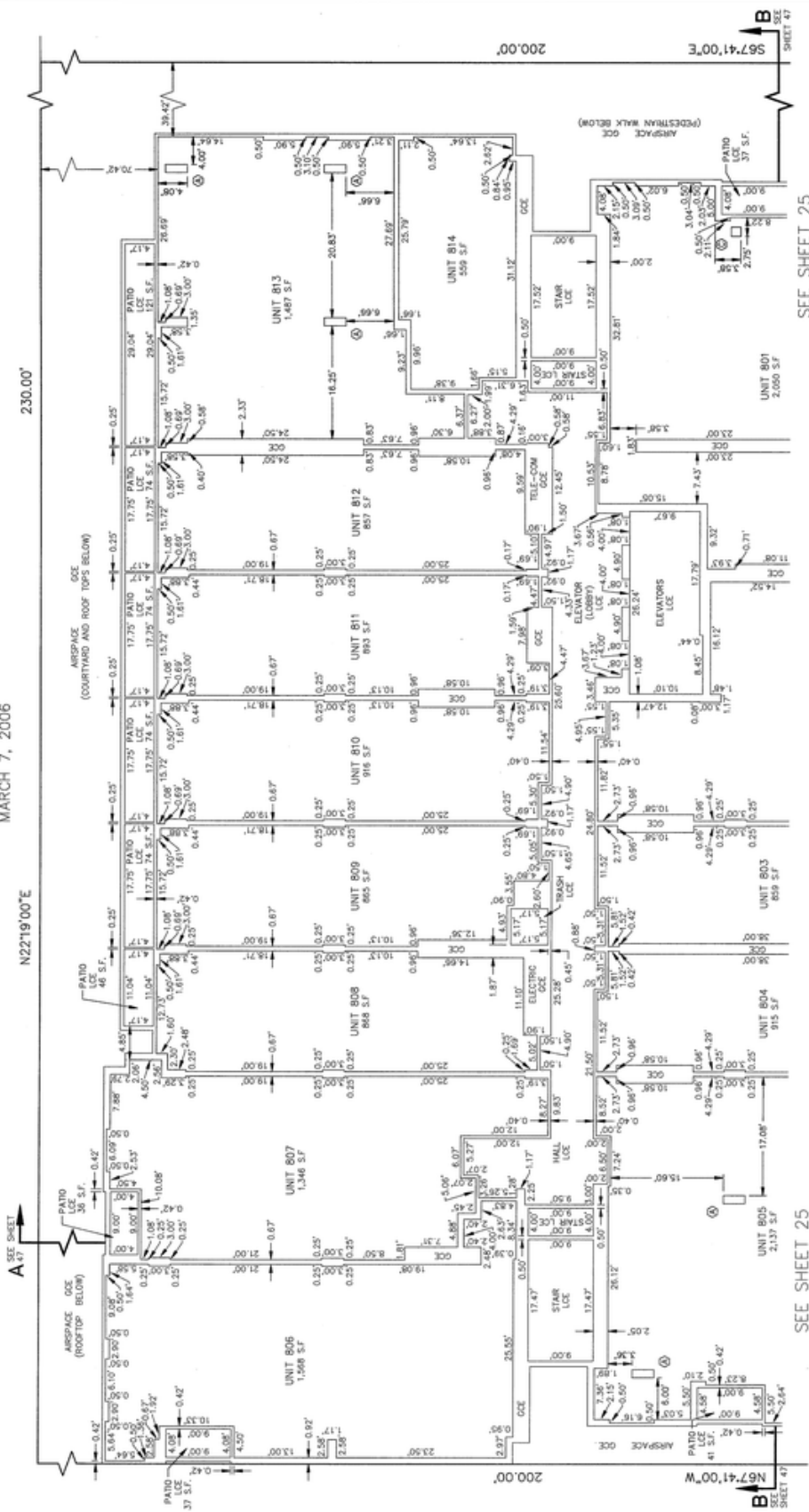

SEE SHEET 25

SEE SHEET 25

SEE SHEET 25

SEE SHEET 25

SEE SHEET 25

SEE SHEET 25

8TH FLOOR—WEST
 I HEREBY CERTIFY THIS TO BE A TRUE AND EXACT COPY OF THE ORIGINAL PLAT
 GARY R. ANDERSON P.L.S. NO. 2434

REGISTERED PROFESSIONAL LAND SURVEYOR
 GARY R. ANDERSON
 JULY 25, 1990
 2434

LEGEND
 UNIT-## PRIMARY UNIT (RESIDENTIAL)
 LCE LIMITED COMMON ELEMENT
 SF SQUARE FEET
 COLUMN TYPE

NOTES
 1. ALL WALLS ARE PARALLEL, PERPENDICULAR OR AT 45 DEGREES TO THE BOUNDARY LINES SHOWN, UNLESS OTHERWISE NOTED.
 2. EXTERIOR THICKNESS SHOWN UNLESS INDICATED THE DIMENSION FROM THAT APPLICABLE BOUNDARY LINE TO THE INTERIOR WALL SURFACE, UNLESS OTHERWISE NOTED.
 3. ALL PRIMARY UNIT DIMENSIONS SHOWN ARE TO THE FACE OF STUD OF THE WALL, OR SURFACE OF CONCRETE WALLS AND COLUMNS.
 4. AREAS UNLABELED ARE GCE.

COLUMN TYPE DETAIL

 1.17' GCE
 1.17'

SCALE: 1" = 10'

SURVEYED BY:
 WESTLAKE CONSULTANTS, INC.
 15115 S.W. SEQUOIA PARKWAY, SUITE 150
 TIGARD, OREGON 97224
 (503)864-0652

RENEWAL DATE
 12-31-07

RENEWAL DATE

RENEWAL DATE

RENEWAL DATE

RENEWAL DATE

BLOCK 246, "CITY OF PORTLAND"
TOGETHER WITH THE SOUTHERLY 30 FEET OF VACATED SW MADISON STREET,
SITUATED IN THE NORTHEAST 1/4 OF SECTION 4, TOWNSHIP 1 SOUTH, RANGE 1 EAST,
WILLAMETTE MERIDIAN, CITY OF PORTLAND, MULTNOMAH COUNTY, OREGON
MARCH 7, 2006

SEE SHEET 24

SEE SHEET 24

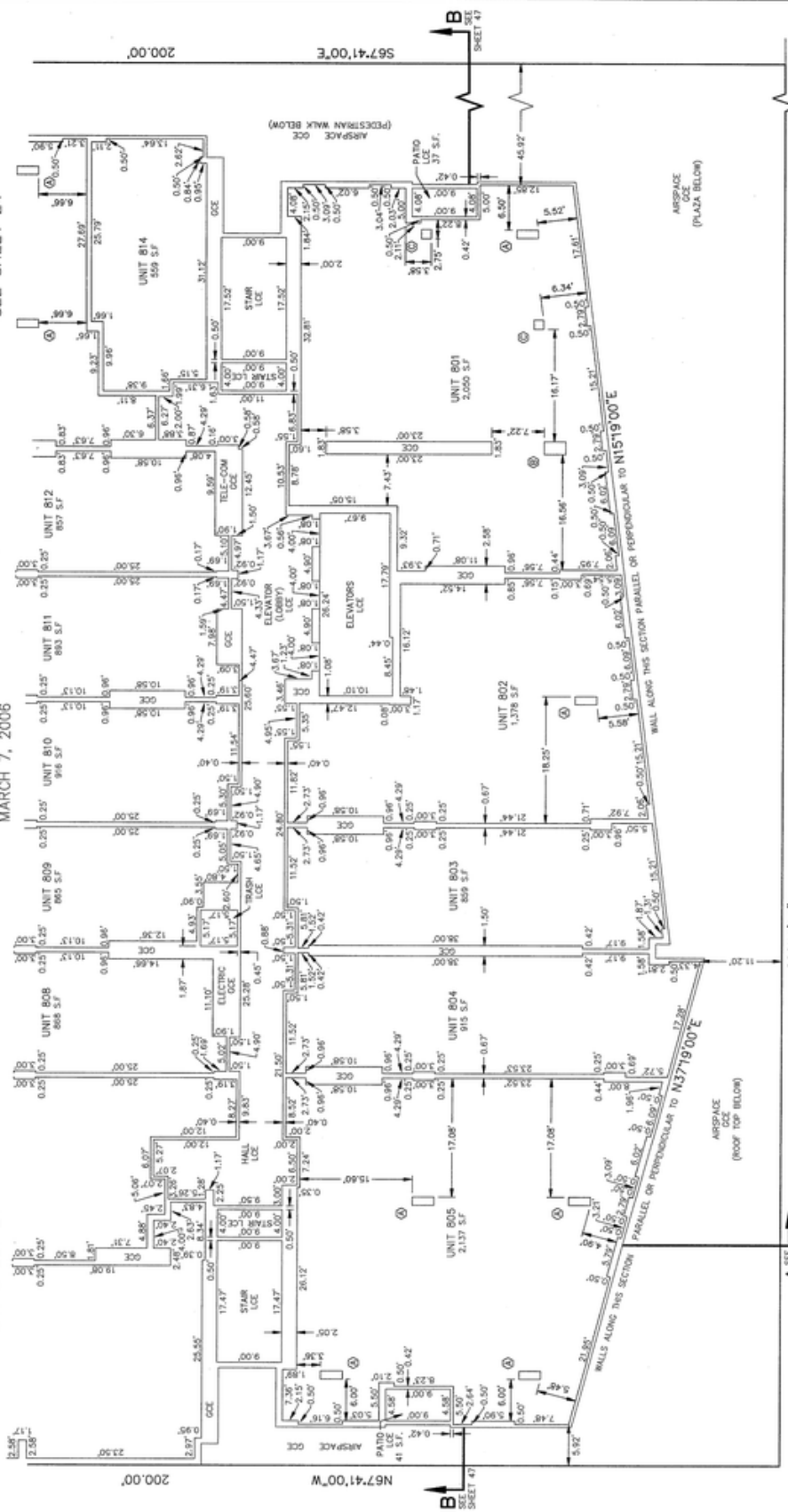

8TH FLOOR—EAST

I HEREBY CERTIFY THIS TO BE A TRUE AND EXACT COPY OF THE ORIGINAL PLAT
GARY R. ANDERSON P.L.S. NO. 2434
SURVEYED BY:
WESTLAKE CONSULTANTS, INC.
15115 S.W. SEQUOIA PARKWAY, SUITE 150
TIGARD, OREGON 97224
(503)864-0652

REGISTERED PROFESSIONAL LAND SURVEYOR
GARY R. ANDERSON
JULY 26, 1990
OREGON 2434

RENEWAL DATE 12-31-07
1042-08(B)
SHEET 25 OF 48

LEGEND

- UNIT-## PRIMARY UNIT (RESIDENTIAL)
- GOE GENERAL COMMON ELEMENT
- LCE LIMITED COMMON ELEMENT
- SF SQUARE FEET
- COLUMN TYPE

NOTES

1. ALL WALLS ARE PARALLEL, PERPENDICULAR OR AT 45 DEGREES TO THE BOUNDARY LINES SHOWN, UNLESS OTHERWISE NOTED.
2. EXTERIOR THICKNESS SHOWN HEREON REPRESENT THE DIMENSION FROM THAT APPLICABLE BOUNDARY LINE TO THE INTERIOR WALL SURFACE, UNLESS OTHERWISE NOTED.
3. ALL PRIMARY UNIT DIMENSIONS SHOWN ARE TO THE FACE OF STUO OF THE WALL OR SURFACE OF CONCRETE WALLS AND COLUMNS.
4. AREAS UNLABELED ARE GOE.

COLUMN TYPE DETAIL

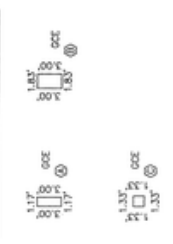

SCALE: 1" = 10'

ELIOT TOWER CONDOMINIUMS

BLOCK 246, "CITY OF PORTLAND"
 TOGETHER WITH THE SOUTHERLY 30 FEET OF VACATED SW MADISON STREET,
 SITUATED IN THE NORTHEAST 1/4 OF SECTION 4, TOWNSHIP 1 SOUTH, RANGE 1 EAST,
 WILLAMETTE MERIDIAN, CITY OF PORTLAND, MULTNOMAH COUNTY, OREGON
 MARCH 7, 2006

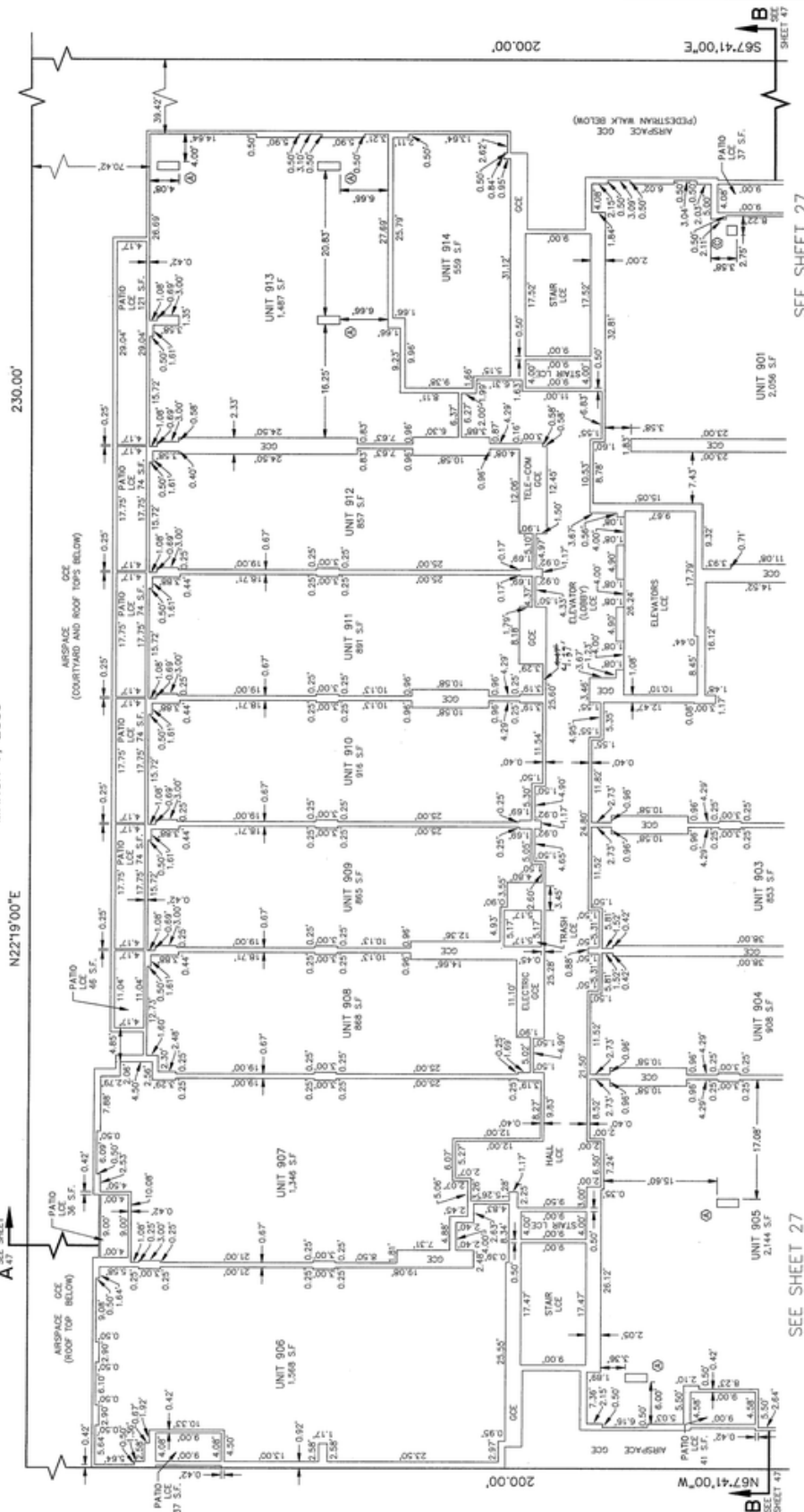

9TH FLOOR—WEST

I HEREBY CERTIFY THIS TO BE A TRUE AND
 EXACT COPY OF THE ORIGINAL PLAT
 GARY R. ANDERSON P.L.S. NO. 2434

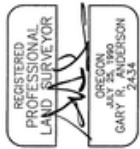

SURVEYED BY:
 WESTLAKE CONSULTANTS, INC.
 15115 S.W. SEQUOIA PARKWAY, SUITE 150
 TIGARD, OREGON 97224
 (503)864-0652

1042-08(9) SHEET 26 OF 48

LEGEND

- UNIT ## PRIMARY UNIT (RESIDENTIAL)
- LIMITED COMMON ELEMENT
- SQUARE FEET
- COLUMN TYPE

NOTES

1. ALL WALLS ARE PARALLEL, PERPENDICULAR OR AT 45 DEGREES TO THE BOUNDARY LINES SHOWN, UNLESS OTHERWISE NOTED.
2. EXTERIOR THICKNESS SHOWN HEREON REPRESENT THE DIMENSION FROM THAT APPLICABLE BOUNDARY LINE TO THE INTERIOR WALL SURFACE, UNLESS OTHERWISE NOTED.
3. ALL PRIMARY UNIT DIMENSIONS SHOWN ARE TO THE FACE OF STALO OF THE WALL OR SURFACE OF CONCRETE WALLS AND COLUMNS.
4. AREAS UNLABELED ARE GCE.

COLUMN TYPE DETAIL

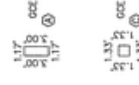

SCALE: 1" = 10'

SEE SHEET 27

SEE SHEET 27

104208(9).DWG

ELIOT TOWER CONDOMINIUMS

BLOCK 246, "CITY OF PORTLAND"
 TOGETHER WITH THE SOUTHERLY 30 FEET OF VACATED SW MADISON STREET,
 SITUATED IN THE NORTHEAST 1/4 OF SECTION 4, TOWNSHIP 1 SOUTH, RANGE 1 EAST,
 WILLAMETTE MERIDIAN, CITY OF PORTLAND, MULTNOMAH COUNTY, OREGON
 MARCH 7, 2006

SEE SHEET 26

SEE SHEET 26

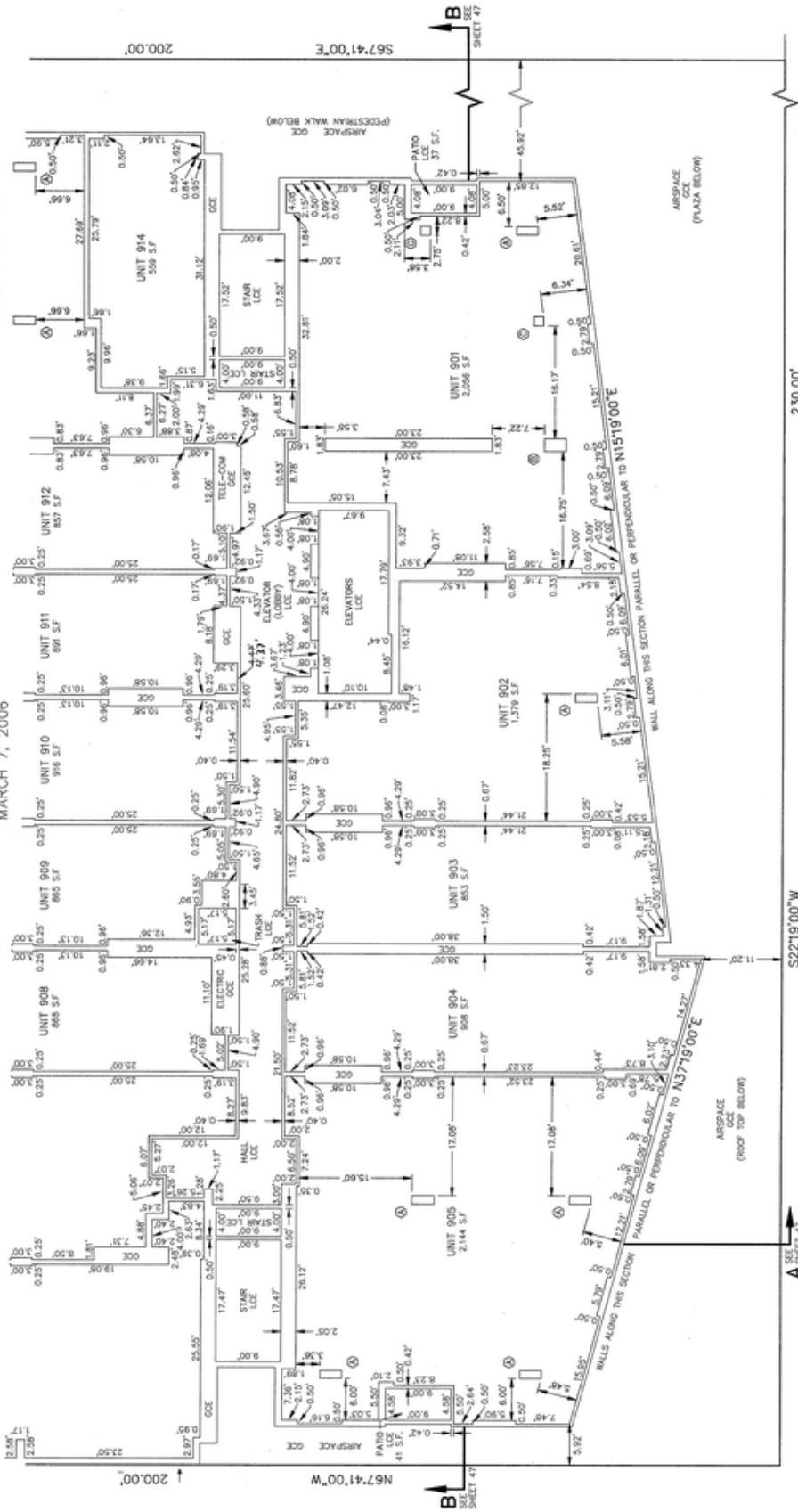

COLUMN TYPE DETAIL

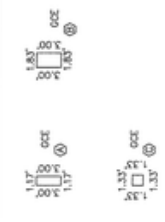

SCALE: 1" = 10'

NOTES

1. ALL WALLS ARE PARALLEL, PERPENDICULAR OR AT 45 DEGREES TO THE BOUNDARY LINES SHOWN, UNLESS OTHERWISE NOTED.
2. EXTERIOR THICKNESS SHOWN HEREON REPRESENT THE DIMENSION FROM THAT APPLICABLE BOUNDARY LINE TO THE INTERIOR WALL SURFACE, UNLESS OTHERWISE NOTED.
3. ALL PRIMARY UNIT DIMENSIONS SHOWN ARE TO THE FACE OF STUD OF THE WALL, OR SURFACE OF CONCRETE WALLS AND COLUMNS.
4. AREAS UNLABELED ARE OCE.

LEGEND

- UNIT-## PRIMARY UNIT (RESIDENTIAL)
- OCE GENERAL COMMON ELEMENT
- LCE SQUARED COMMON ELEMENT
- SF SQUARE FEET
- COLUMN TYPE

9TH FLOOR-EAST

I HEREBY CERTIFY THIS TO BE A TRUE AND EXACT COPY OF THE ORIGINAL PLAT
 GARY R. ANDERSON P.L.S. NO. 2434
 SURVEYED BY:
 WESTLAKE CONSULTANTS, INC.
 1515 S.W. SCODIO PARKWAY, SUITE 150
 PORTLAND, OREGON 97224
 (503)854-0852

REGISTERED PROFESSIONAL LAND SURVEYOR
 GARY R. ANDERSON
 OREGON
 JULY 28, 1990
 2434

RENEWAL DATE
 12-31-07

ELIOT TOWER CONDOMINIUMS

BLOCK 246, "CITY OF PORTLAND"
 TOGETHER WITH THE SOUTHERLY 30 FEET OF VACATED SW MADISON STREET,
 SITUATED IN THE NORTHEAST 1/4 OF SECTION 4, TOWNSHIP 1 SOUTH, RANGE 1 EAST,
 WILLAMETTE MERIDIAN, CITY OF PORTLAND, MULTNOMAH COUNTY, OREGON
 MARCH 7, 2006

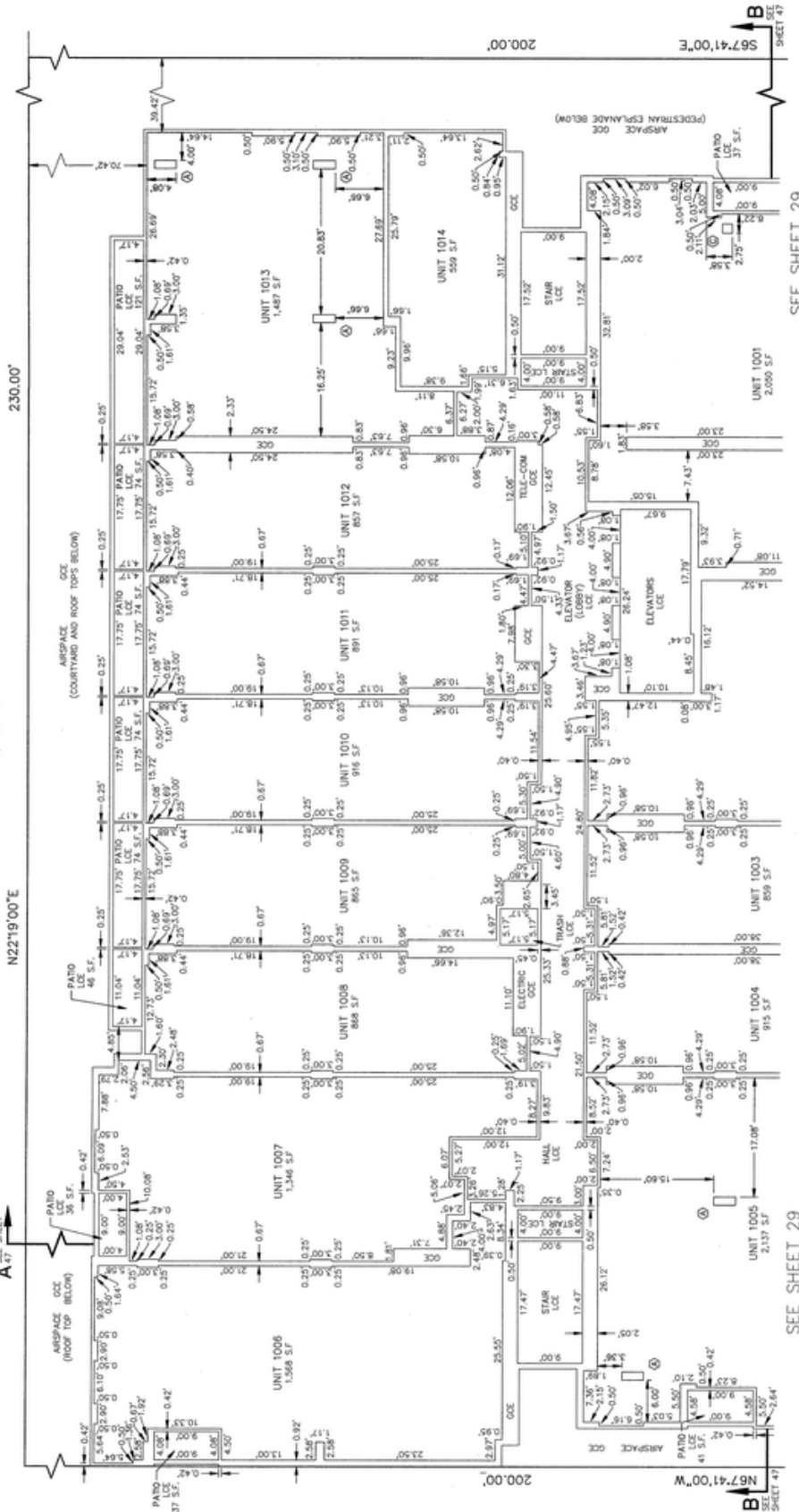

SEE SHEET 29

SEE SHEET 29

SEE SHEET 29

SEE SHEET 29

SEE SHEET 29

SEE SHEET 29

SEE SHEET 29

SEE SHEET 29

10TH FLOOR—WEST
 I HEREBY CERTIFY THIS TO BE A TRUE AND
 EXACT COPY OF THE ORIGINAL PLAT
 GARY R. ANDERSON P.L.S. NO. 2434

REGISTERED
 PROFESSIONAL
 LAND SURVEYOR
 GARY R. ANDERSON
 JUNE 25, 1990
 2434

LEGEND
 UNIT ## PRIMARY UNIT (RESIDENTIAL)
 LCE LIMITED COMMON ELEMENT
 SF SQUARE FEET
 C COLUMN TYPE

NOTES
 1. ALL WALLS ARE PARALLEL, PERPENDICULAR OR AT 45 DEGREES TO THE
 BOUNDARY LINES SHOWN, UNLESS OTHERWISE NOTED.
 2. EXTERIOR THICKNESS SHOWN HEREON REPRESENT THE DIMENSION FROM
 THAT APPLICABLE BOUNDARY LINE TO THE INTERIOR WALL SURFACE, UNLESS
 OTHERWISE NOTED.
 3. ALL PRIMARY UNIT DIMENSIONS SHOWN ARE TO THE FACE OF STUD OF
 THE WALL OR SURFACE OF CONCRETE WALLS AND COLUMNS.
 4. AREAS UNLABLED ARE GCE.

COLUMN TYPE DETAIL

SCALE: 1" = 10'

RENEWAL DATE

104208710.DWG

SHEET 28 OF 48

1042-08(B)

12-31-07

SURVEYED BY:
 WESTLAKE CONSULTANTS, INC.
 15115 S.W. SEQUOIA PARKWAY, SUITE 150
 TIGARD, OREGON 97224
 (503)884-0652

ELIOT TOWER CONDOMINIUMS

PLAT BOOK 1735 PAGE 43

BLOCK 246, "CITY OF PORTLAND"
TOGETHER WITH THE SOUTHERLY 30 FEET OF VACATED SW MADISON STREET,
SITUATED IN THE NORTHEAST 1/4 OF SECTION 4, TOWNSHIP 1 SOUTH, RANGE 1 EAST,
WILLAMETTE MERIDIAN, CITY OF PORTLAND, MULTNOMAH COUNTY, OREGON
MARCH 7, 2006

SEE SHEET 28

SEE SHEET 28

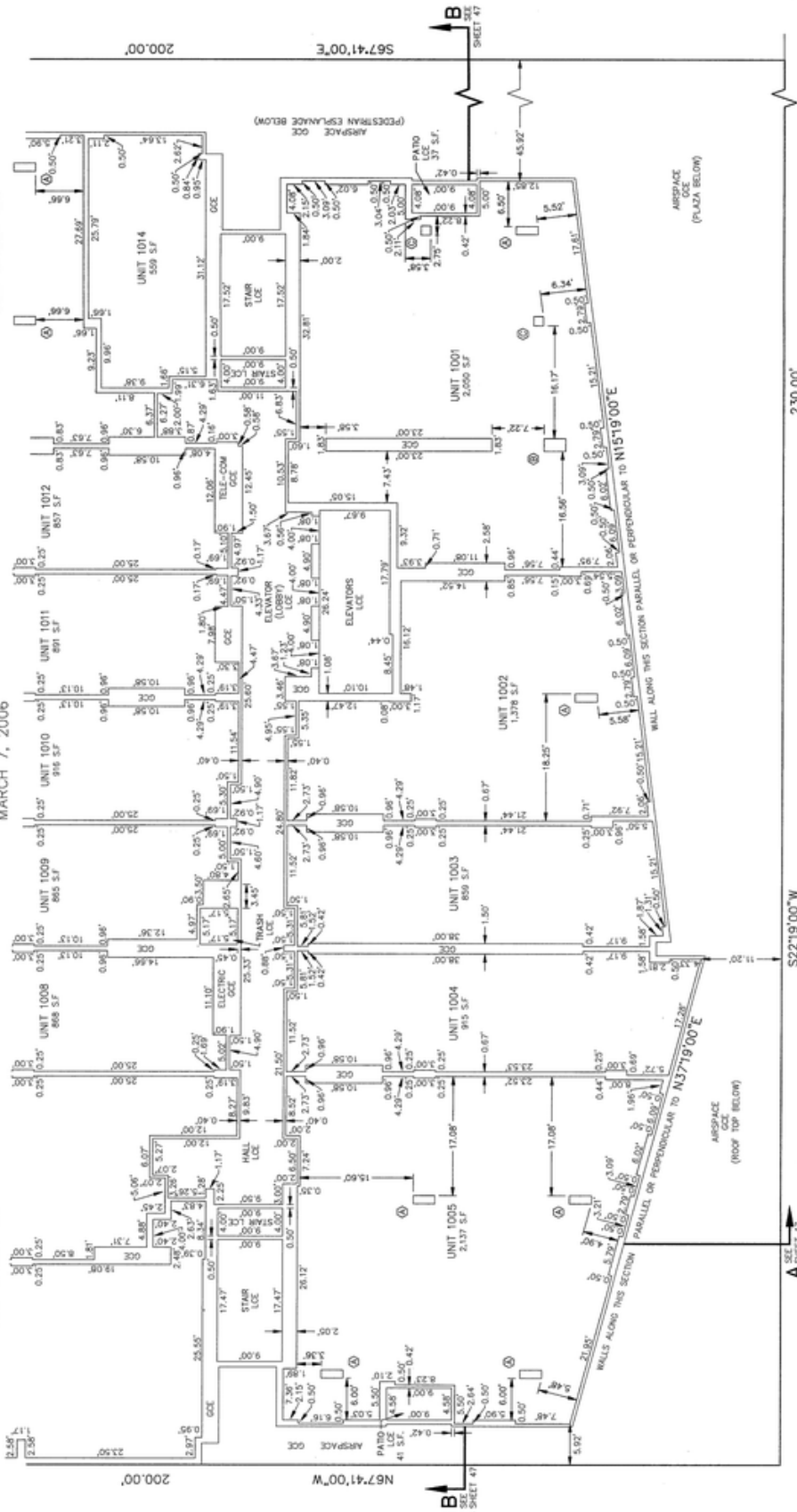

COLUMN TYPE DETAIL

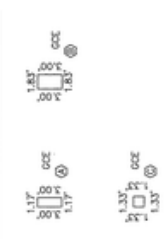

SCALE: 1" = 10'

NOTES

1. ALL WALLS ARE PARALLEL, PERPENDICULAR OR AT 45 DEGREES TO THE BOUNDARY LINES SHOWN, UNLESS OTHERWISE NOTED.
2. EXTERIOR THICKNESS SHOWN HEREON REPRESENT THE DIMENSION FROM THAT APPLICABLE BOUNDARY LINE TO THE INTERIOR WALL SURFACE, UNLESS OTHERWISE NOTED.
3. ALL PRIMARY UNIT DIMENSIONS SHOWN ARE TO THE FACE OF STUD OF THE WALL, OR SURFACE OF CONCRETE WALLS AND COLUMNS.
4. AREAS UNLABELED ARE GCE.

LEGEND

- UNIT-## PRIMARY UNIT (RESIDENTIAL)
- GCE GENERAL COMMON ELEMENT
- LCE LIMITED COMMON ELEMENT
- SF SQUARE FEET
- COLUMN TYPE

10TH FLOOR-EAST

I HEREBY CERTIFY THIS TO BE A TRUE AND EXACT COPY OF THE ORIGINAL PLAT

GARY R. ANDERSON
REGISTERED PROFESSIONAL LAND SURVEYOR
JULY 25, 1990
OREGON P.L.S. NO. 2434

GARY R. ANDERSON
REGISTERED PROFESSIONAL LAND SURVEYOR
JULY 25, 1990
OREGON P.L.S. NO. 2434

SURVEYED BY:
WESTLAKE CONSULTANTS, INC.
10115 S.W. SECOOIA PARKWAY, SUITE 150
PORTLAND, OREGON 97224
(503)864-0652

RENEWAL DATE
12-31-07

1042-06(B) SHEET 29 OF 48

104208710.DWG

ELIOT TOWER CONDOMINIUMS

BLOCK 246, "CITY OF PORTLAND"
 TOGETHER WITH THE SOUTHERLY 30 FEET OF VACATED SW MADISON STREET,
 SITUATED IN THE NORTHEAST 1/4 OF SECTION 4, TOWNSHIP 1 SOUTH, RANGE 1 EAST,
 WILLAMETTE MERIDIAN, CITY OF PORTLAND, MULTNOMAH COUNTY, OREGON
 MARCH 7, 2006

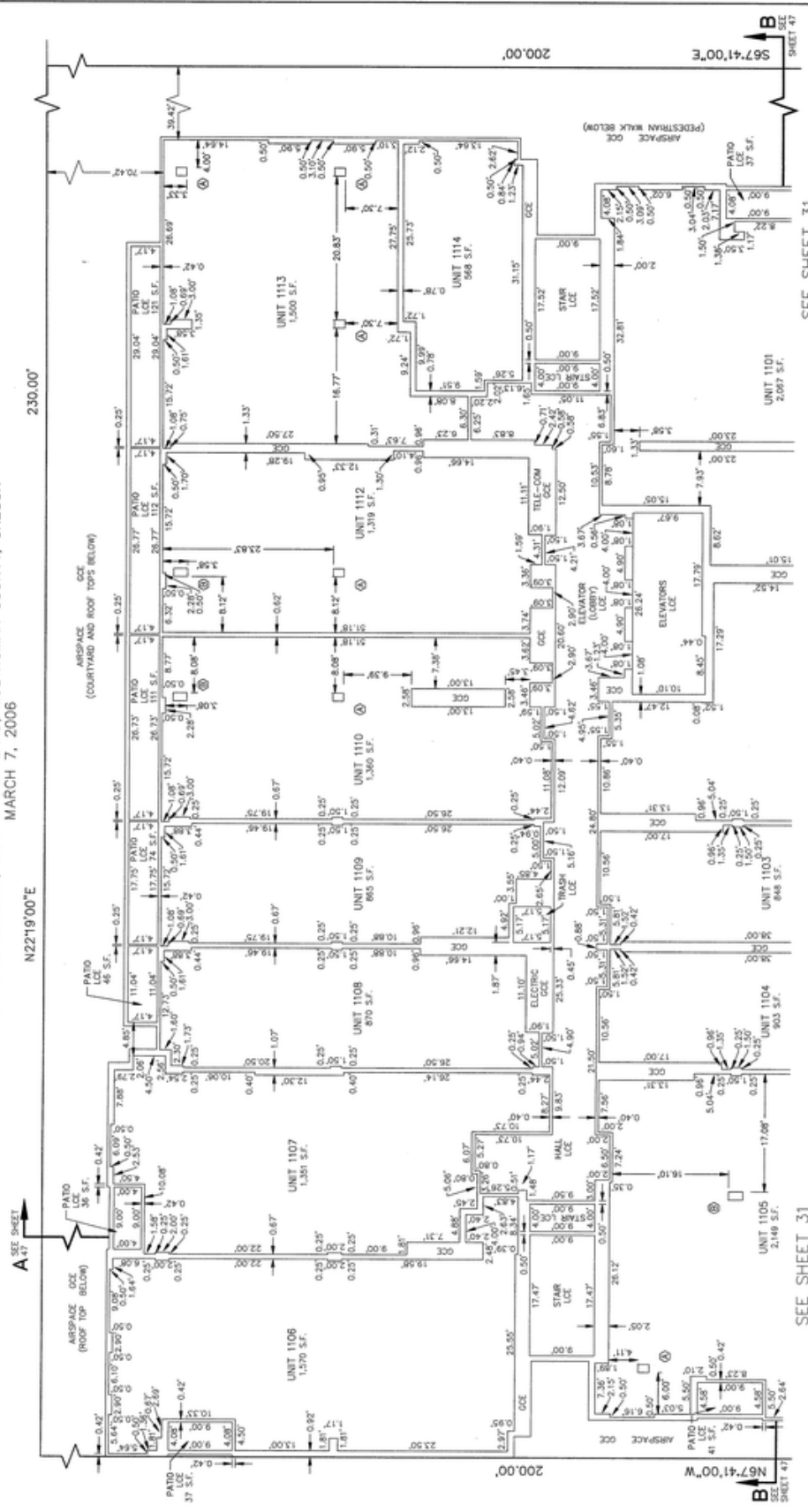

11TH FLOOR—WEST
 I HEREBY CERTIFY THIS TO BE A TRUE AND
 EXACT COPY OF THE ORIGINAL PLAT
 GARY R. ANDERSON P.L.S. NO. 2204
 SURVEYED BY:
 WESTLAKE CONSULTANTS, INC.
 1915 S.W. SCODDIA PARKWAY, SUITE 150
 TIGARD, OREGON 97124
 (503)864-0652

REGISTERED
 PROFESSIONAL
 LAND SURVEYOR
 GARY R. ANDERSON
 OREGON
 JULY 25, 1998
 2434
 RENEWAL DATE
 12-31-07
 1042-08(B)
 SHEET 30 OF 48

LEGEND
 UNIT-## PRIMARY UNIT (RESIDENTIAL)
 GCE GENERAL COMMON ELEMENT
 LCE LIMITED COMMON ELEMENT
 S.F. SQUARE FEET
 C COLUMN TYPE

NOTES
 1. ALL WALLS ARE PARALLEL, PERPENDICULAR OR AT 45 DEGREES TO THE
 BOUNDARY LINES SHOWN, UNLESS OTHERWISE NOTED.
 2. EXTERIOR THICKNESS SHOWN HORIZON REPRESENTS THE DIMENSION FROM
 THE APPLICABLE BOUNDARY LINE TO THE INTERIOR WALL SURFACE, UNLESS
 OTHERWISE NOTED.
 3. ALL PRIMARY UNIT DIMENSIONS SHOWN ARE TO THE FACE OF STUD OF
 THE WALL, OR SURFACE OF CONCRETE WALLS AND COLUMNS.
 4. AREAS UNLABELED ARE GCE.

COLUMN TYPE DETAIL

 SCALE: 1" = 10'
 SEE SHEET 31



ELIOT TOWER CONDOMINIUMS

BLOCK 246, "CITY OF PORTLAND"
 TOGETHER WITH THE SOUTHERLY 30 FEET OF VACATED SW MADISON STREET,
 SITUATED IN THE NORTHEAST 1/4 OF SECTION 4, TOWNSHIP 1 SOUTH, RANGE 1 EAST,
 WILLAMETTE MERIDIAN, CITY OF PORTLAND, MULTNOMAH COUNTY, OREGON
 MARCH 7, 2006

SEE SHEET 30

SEE SHEET 30

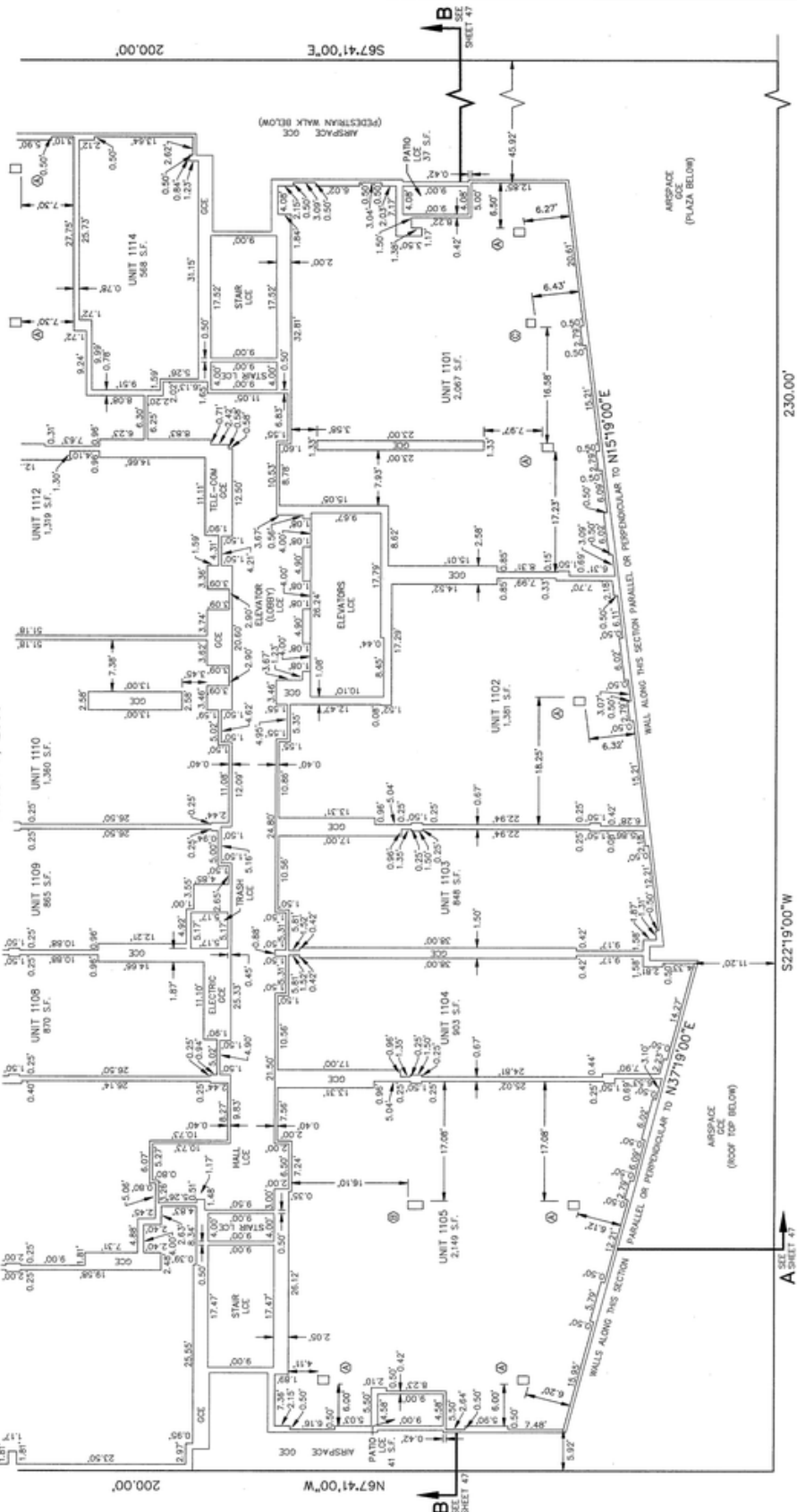

11TH FLOOR—EAST

I HEREBY CERTIFY THIS TO BE A TRUE AND EXACT COPY OF THE ORIGINAL PLAT
 GARY R. ANDERSON P.L.S. NO. 2434

REGISTERED PROFESSIONAL LAND SURVEYOR
 GARY R. ANDERSON
 JULY 26, 1990
 GARY R. ANDERSON 2434

LEGEND

- UNIT-## PRIMARY UNIT (RESIDENTIAL)
- GENERAL COMMON ELEMENT
- LCE SQUARED COMMON ELEMENT
- S.F. SQUARE FEET
- COLUMN TYPE

NOTES

1. ALL WALLS ARE PARALLEL, PERPENDICULAR OR AT 45 DEGREES TO THE BOUNDARY LINES SHOWN, UNLESS OTHERWISE NOTED.
2. EXTERIOR THICKNESS SHOWN HEREON REPRESENT THE DIMENSION FROM THAT APPLICABLE BOUNDARY LINE TO THE INTERIOR WALL SURFACE, UNLESS OTHERWISE NOTED.
3. ALL PRIMARY UNIT DIMENSIONS SHOWN ARE TO THE FACE OF STUD OF THE WALL OR SURFACE OF CONCRETE WALLS AND COLUMNS.
4. AREAS UNLABELED ARE G.C.E.

COLUMN TYPE DETAIL



SCALE: 1" = 10'

RENEWAL DATE 12-31-07

1042-00(8)

SHEET 31 OF 48

104208F11.DWG

ELIOT TOWER CONDOMINIUMS

BLOCK 246, "CITY OF PORTLAND"
 TOGETHER WITH THE SOUTHERLY 30 FEET OF VACATED SW MADISON STREET,
 SITUATED IN THE NORTHEAST 1/4 OF SECTION 4, TOWNSHIP 1 SOUTH, RANGE 1 EAST,
 WILLAMETTE MERIDIAN, CITY OF PORTLAND, MULTNOMAH COUNTY, OREGON
 MARCH 7, 2006

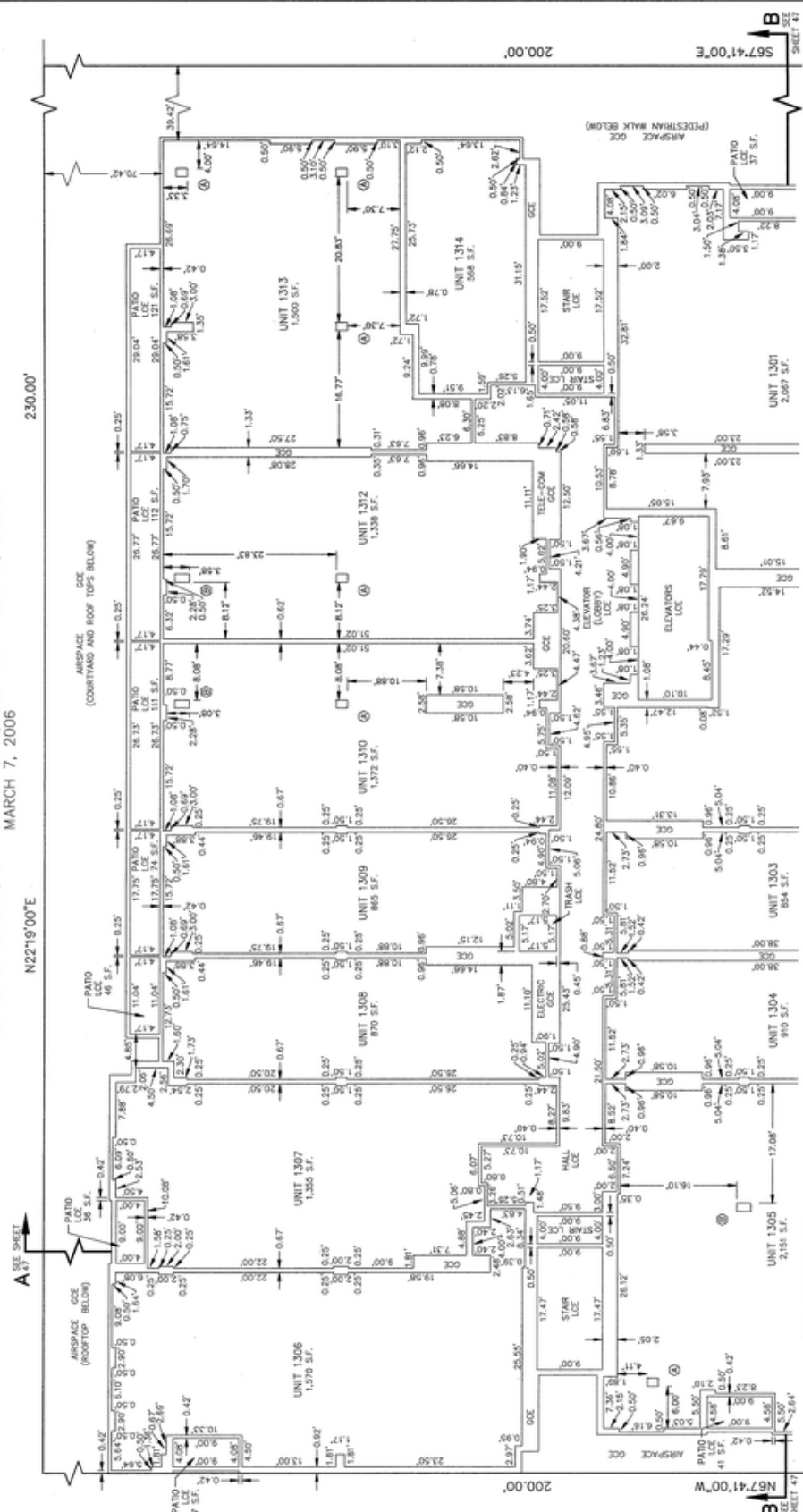

SEE SHEET 35

SEE SHEET 35

SEE SHEET 35

SEE SHEET 35

SEE SHEET 35

SEE SHEET 35

SEE SHEET 35

13TH FLOOR - WEST

REGISTERED PROFESSIONAL LAND SURVEYOR

LEGEND

NOTES

COLUMN TYPE DETAIL

SCALE: 1" = 10'

1042087130W3

I HEREBY CERTIFY THIS TO BE A TRUE AND CORRECT COPY OF THE ORIGINAL PLAT.
 GARY R. ANDERSON P.L.S. NO. 2434

REGISTERED PROFESSIONAL LAND SURVEYOR
 GARY R. ANDERSON
 OREGON
 P.L.S. NO. 2434

PRIMARY UNIT (RESIDENTIAL)
 GENERAL COMMON ELEMENT
 LIMITED COMMON ELEMENT
 SQUARE FEET
 COLUMN TYPE

1. ALL WALLS ARE PARALLEL, PERPENDICULAR OR AT 45 DEGREES TO THE BOUNDARY LINES SHOWN, UNLESS OTHERWISE NOTED.
 2. EXTERIOR THICKNESS SHOWN HEREON REPRESENT THE DIMENSION FROM THE EXTERIOR FACE OF THE WALL TO THE INTERIOR WALL SURFACE, UNLESS OTHERWISE NOTED.
 3. ALL PRIMARY UNIT DIMENSIONS SHOWN ARE TO THE FACE OF STUD OF THE WALL OR SURFACE OF CONCRETE WALLS AND COLUMNS.
 4. AREAS UNLABLED ARE G.O.E.

1.17' G.O.E.
 1.17' G.O.E.
 1.17' G.O.E.
 1.17' G.O.E.

1.17' G.O.E.
 1.17' G.O.E.

1042087130W3

1042-08(B)
 12-31-07
 RENEWAL DATE

1042-08(B)

1042-08(B)

1042-08(B)

1042-08(B)

1042-08(B)

1042-08(B)

1042-08(B)

1042-08(B)

1042-08(B)

1042-08(B)

1042-08(B)

1042-08(B)

1042-08(B)

1042-08(B)

1042-08(B)

1042-08(B)

1042-08(B)

1042-08(B)

1042-08(B)

1042-08(B)

1042-08(B)

1042-08(B)

1042-08(B)

1042-08(B)

1042-08(B)

1042-08(B)

1042-08(B)

1042-08(B)

1042-08(B)

1042-08(B)

1042-08(B)

1042-08(B)

1042-08(B)

1042-08(B)

1042-08(B)

1042-08(B)

1042-08(B)

1042-08(B)

1042-08(B)

1042-08(B)

1042-08(B)

1042-08(B)

1042-08(B)

1042-08(B)

1042-08(B)

1042-08(B)

1042-08(B)

1042-08(B)

1042-08(B)

1042-08(B)

1042-08(B)

1042-08(B)

1042-08(B)

1042-08(B)

1042-08(B)

1042-08(B)

1042-08(B)

1042-08(B)

1042-08(B)

1042-08(B)

1042-08(B)

1042-08(B)

1042-08(B)

1042-08(B)

1042-08(B)

1042-08(B)

1042-08(B)

1042-08(B)

1042-08(B)

1042-08(B)

1042-08(B)

1042-08(B)

1042-08(B)

1042-08(B)

1042-08(B)

1042-08(B)

1042-08(B)

1042-08(B)

1042-08(B)

1042-08(B)

1042-08(B)

1042-08(B)

1042-08(B)

1042-08(B)

1042-08(B)

1042-08(B)

1042-08(B)

1042-08(B)

1042-08(B)

1042-08(B)

1042-08(B)

1042-08(B)

1042-08(B)

1042-08(B)

1042-08(B)

1042-08(B)

1042-08(B)

1042-08(B)

1042-08(B)

1042-08(B)

1042-08(B)

1042-08(B)

1042-08(B)

1042-08(B)

1042-08(B)

1042-08(B)

1042-08(B)

1042-08(B)

1042-08(B)

1042-08(B)

1042-08(B)

1042-08(B)

1042-08(B)

1042-08(B)

1042-08(B)

1042-08(B)

1042-08(B)

1042-08(B)

1042-08(B)

1042-08(B)

1042-08(B)

1042-08(B)

1042-08(B)

1042-08(B)

1042-08(B)

1042-08(B)

1042-08(B)

1042-08(B)

1042-08(B)

1042-08(B)

1042-08(B)

1042-08(B)

1042-08(B)

1042-08(B)

1042-08(B)

1042-08(B)

1042-08(B)

1042-08(B)

1042-08(B)

1042-08(B)

1042-08(B)

1042-08(B)

1042-08(B)

1042-08(B)

1042-08(B)

1042-08(B)

1042-08(B)

1042-08(B)

1042-08(B)

1042-08(B)

1042-08(B)

1042-08(B)

1042-08(B)

1042-08(B)

1042-08(B)

1042-08(B)

1042-08(B)

1042-08(B)

1042-08(B)

1042-08(B)

1042-08(B)

1042-08(B)

1042-08(B)

1042-08(B)

1042-08(B)

1042-08(B)

1042-08(B)

1042-08(B)

1042-08(B)

1042-08(B)

1042-08(B)

1042-08(B)

1042-08(B)

1042-08(B)

1042-08(B)

1042-08(B)

1042-08(B)

1042-08(B)

1042-08(B)

1042-08(B)

1042-08(B)

1042-08(B)

1042-08(B)

1042-08(B)

1042-08(B)

1042-08(B)

1042-08(B)

1042-08(B)

1042-08(B)

1042-08(B)

1042-08(B)

1042-08(B)

1042-08(B)

1042-08(B)

1042-08(B)

1042-08(B)

1042-08(B)

1042-08(B)

1042-08(B)

1042-08(B)

1042-08(B)

1042-08(B)

1042-08(B)

1042-08(B)

1042-08(B)

1042-08(B)

1042-08(B)

1042-08(B)

1042-08(B)

1042-08(B)

1042-08(B)

1042-08(B)

1042-08(B)

1042-08(B)

1042-08(B)

1042-08(B)

1042-08(B)

1042-08(B)

1042-08(B)

1042-08(B)

1042-08(B)

1042-08(B)

1042-08(B)

1042-08(B)

1042-08(B)

1042-08(B)

1042-08(B)

1042-08(B)

ELIOT TOWER CONDOMINIUMS

BLOCK 246, "CITY OF PORTLAND"
 TOGETHER WITH THE SOUTHERLY 30 FEET OF VACATED SW MADISON STREET,
 SITUATED IN THE NORTHEAST 1/4 OF SECTION 4, TOWNSHIP 1 EAST,
 WILLAMETTE MERIDIAN, CITY OF PORTLAND, MULTNOMAH COUNTY, OREGON
 MARCH 7, 2006

SEE SHEET 34

SEE SHEET 34

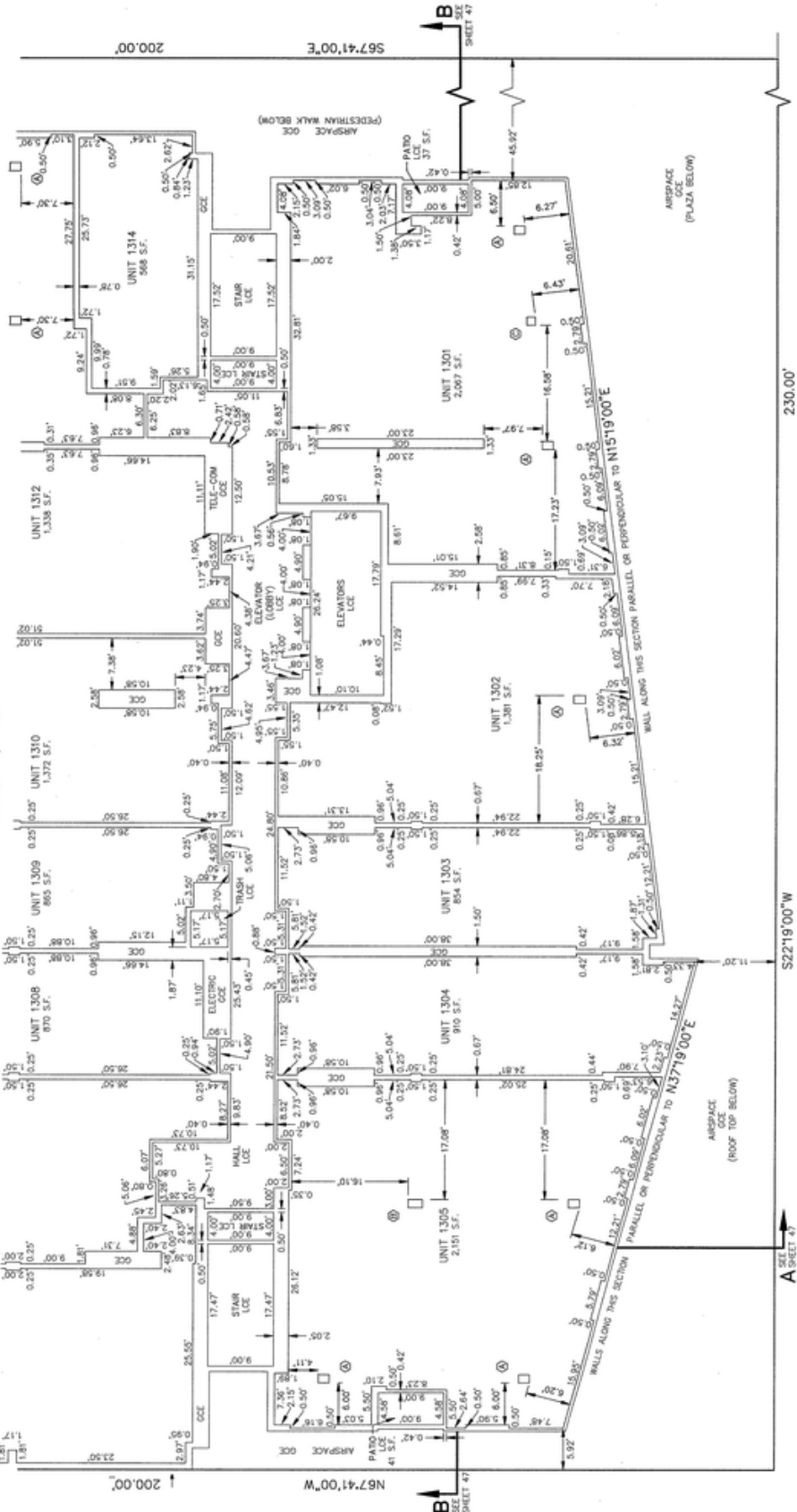

13TH FLOOR—EAST



LEGEND

- UNIT-### PRIMARY UNIT (RESIDENTIAL)
- COMMON ELEMENT
- LIMITED COMMON ELEMENT
- SF. SQUARE FEET
- COLUMN TYPE

NOTES

1. ALL WALLS ARE PARALLEL, PERPENDICULAR OR AT 45 DEGREES TO THE BOUNDARY LINES SHOWN, UNLESS OTHERWISE NOTED.
2. EXTERIOR THICKNESS SHOWN HEREON REPRESENT THE DIMENSION FROM THAT APPLICABLE BOUNDARY LINE TO THE INTERIOR WALL SURFACE, UNLESS OTHERWISE NOTED.
3. ALL PRIMARY UNIT DIMENSIONS SHOWN ARE TO THE FACE OF STUD OF THE WALL OR SURFACE OF CONCRETE WALLS AND COLUMNS.
4. AREAS UNLABELED ARE G.C.E.

COLUMN TYPE DETAIL



SCALE: 1" = 10'

I HEREBY CERTIFY THIS TO BE A TRUE AND EXACT COPY OF THE ORIGINAL PLAT

SURVEYED BY:
 WESTLAKE CONSULTANTS, INC.
 15115 S.W. SEQUOIA PARKWAY, SUITE 150
 TIGARD, OREGON 97224
 (503)684-6652

GARY R. ANDERSON P.L.S. NO. 2454

RENEWAL DATE

12-31-07

SHEET 35 OF 48

104208F13.0WG

BLOCK 246, "CITY OF PORTLAND"
 TOGETHER WITH THE SOUTHERLY 30 FEET OF VACATED SW MADISON STREET,
 SITUATED IN THE NORTHEAST 1/4 OF SECTION 4, TOWNSHIP 1 SOUTH, RANGE 1 EAST,
 WILLAMETTE MERIDIAN, CITY OF PORTLAND, MULTNOMAH COUNTY, OREGON
 MARCH 7, 2006

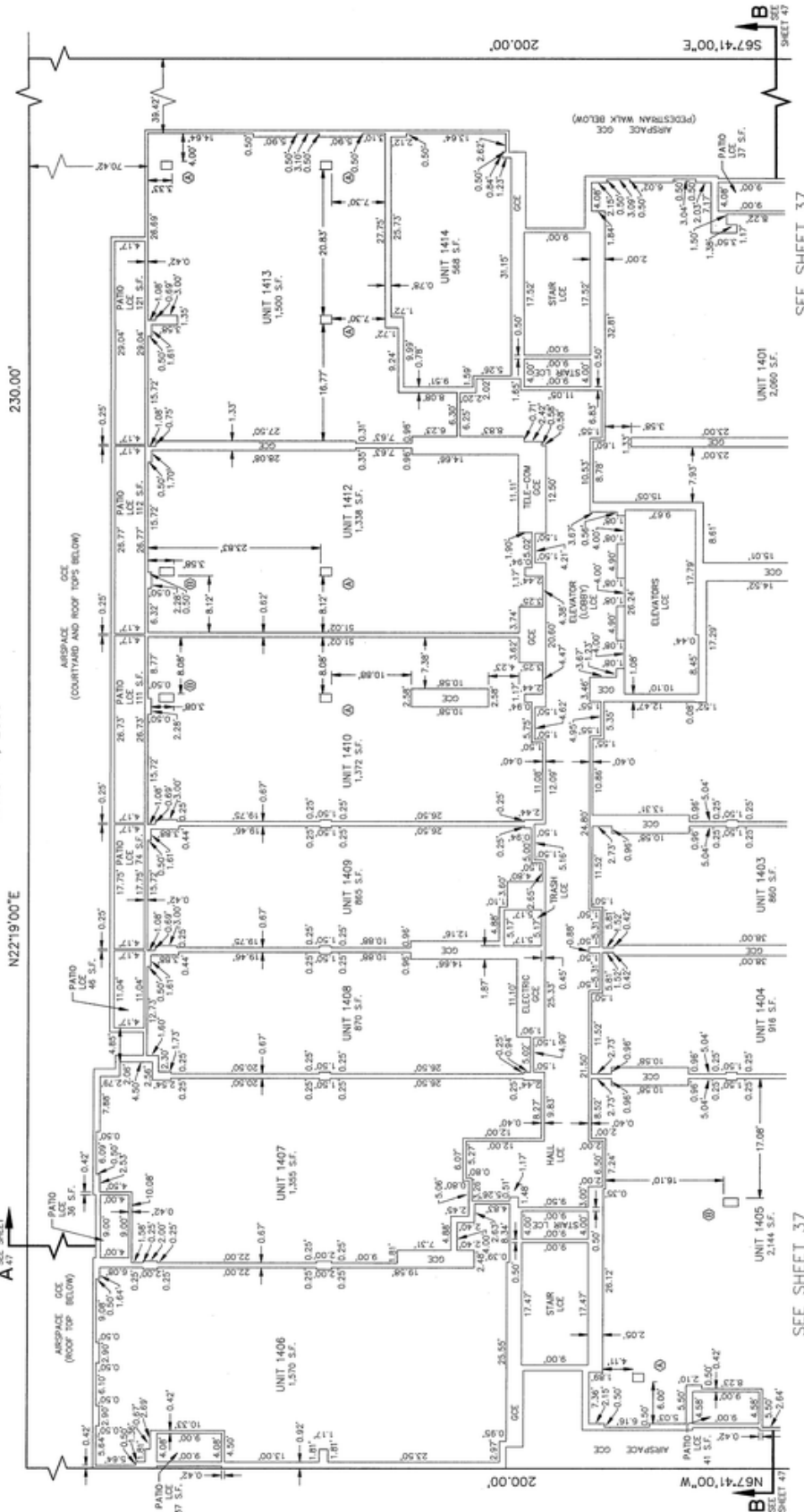

14TH FLOOR—WEST

I HEREBY CERTIFY THIS TO BE A TRUE AND EXACT COPY OF THE ORIGINAL PLAT
 GARY R. ANDERSON P.L.L.C. NO. 2434

REGISTERED PROFESSIONAL LAND SURVEYOR
 GARY R. ANDERSON
 OREGON LICENSE NO. 2434

LEGEND

- UNIT-## PRIMARY UNIT (RESIDENTIAL)
- LOBBY COMMON ELEMENT
- LOBBY COMMON ELEMENT
- LOBBY COMMON ELEMENT
- S.F. SQUARE FEET
- COLUMN TYPE

NOTES

1. ALL WALLS ARE PARALLEL PERPENDICULAR OR AT 45 DEGREES TO THE BOUNDARY LINES SHOWN, UNLESS OTHERWISE NOTED.
2. ELEVATOR THRESHOLDS SHOWN HEREIN REPRESENT THE AMERICAN BIRM THAT APPLICABLE BOUNDARY LINE TO THE OUTDOOR WALL SURFACE, UNLESS OTHERWISE NOTED.
3. ALL PRIMARY UNIT DIMENSIONS SHOWN ARE TO THE FACE OF STUD OF THE WALL, OR SURFACE OF CONCRETE WALLS AND COLUMNS.
4. AREAS UNLABELED ARE GZE.

COLUMN TYPE DETAIL

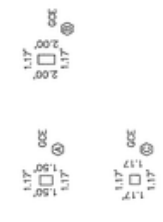

SEE SHEET 37

SEE SHEET 37

ELIOT TOWER CONDOMINIUMS

TOGETHER WITH THE SOUTHERLY 30 FEET OF VACATED SW MADISON STREET,
 BLOCK 246, "CITY OF PORTLAND"
 SITUATED IN THE NORTHEAST 1/4 OF SECTION 4, TOWNSHIP 1 SOUTH, RANGE 1 EAST,
 WILLAMETTE MERIDIAN, CITY OF PORTLAND, MULTNOMAH COUNTY, OREGON
 MARCH 7, 2006

PLAT BOOK 1275 PAGE 51

SEE SHEET 36

SEE SHEET 36

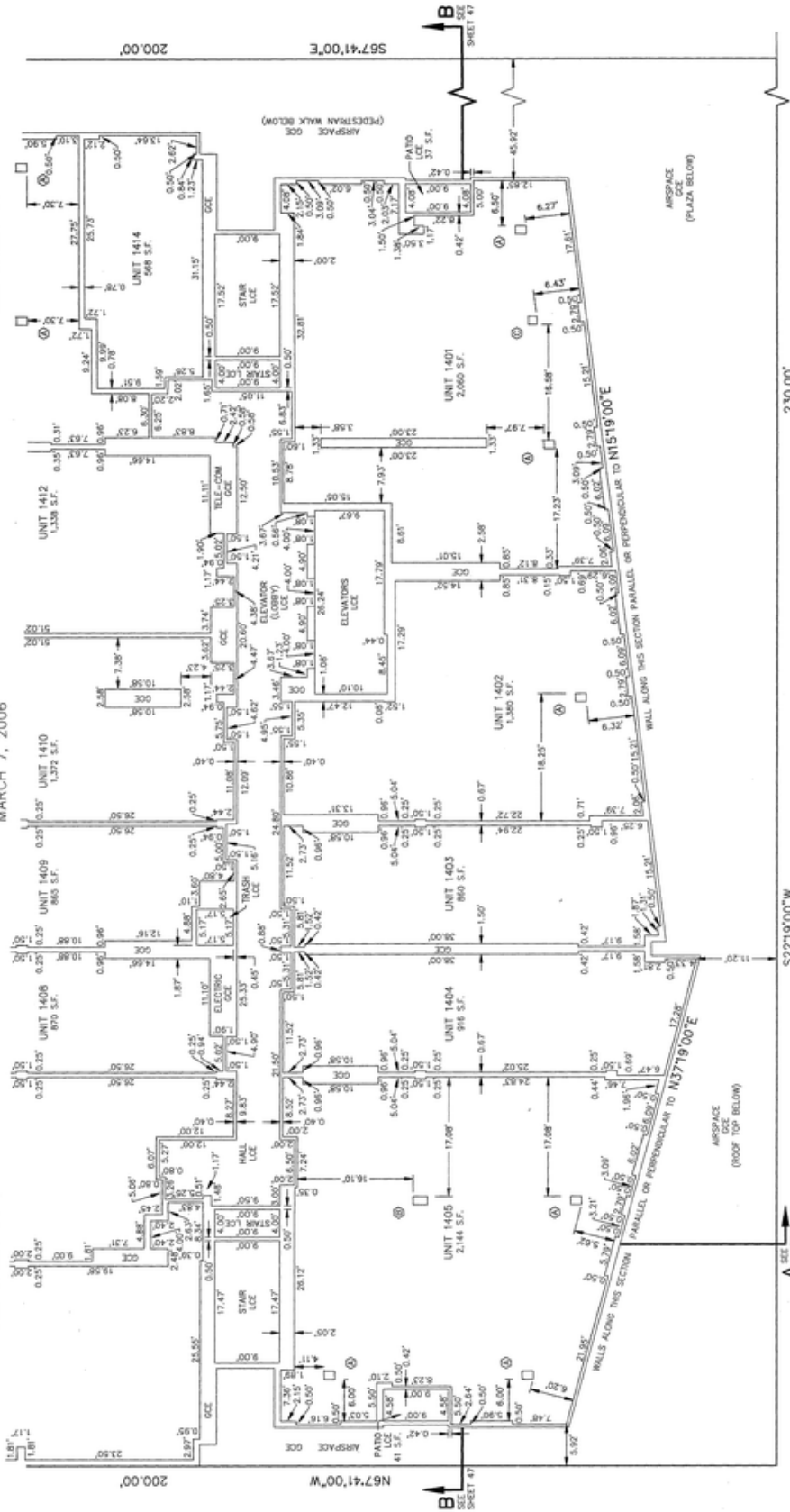

COLUMN TYPE DETAIL

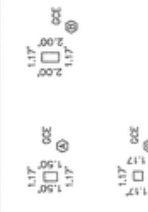

NOTES

1. WALLS ARE PARALLEL, PERPENDICULAR OR AT 45 DEGREES TO THE BOUNDARIES SHOWN, UNLESS OTHERWISE NOTED.
2. DIMENSIONS SHOWN BETWEEN FACES REPRESENT THE DIMENSION FROM EXTERIOR SURFACE TO EXTERIOR SURFACE UNLESS OTHERWISE NOTED.
3. ALL PRIMARY UNIT DIMENSIONS SHOWN ARE TO THE FACE OF STUD OF THE WALL OR SURFACE OF CONCRETE WALLS AND COLUMNS.
4. AREAS UNLABELED ARE GCE.

LEGEND

- UNIT-## PRIMARY UNIT (RESIDENTIAL)
- GCE GENERAL COMMON ELEMENT
- STAIR STAIR COMMON ELEMENT
- SF SQUARE FEET
- COLUMN TYPE

14TH FLOOR-EAST

I HEREBY CERTIFY THIS TO BE A TRUE AND
 EXACT COPY OF THE ORIGINAL PLAT

GARY R. ANDERSON P.L.S. NO. 2448

SURVEYED BY:
 WESTLAKE CONSULTANTS, INC.
 15115 S.W. SEQUOIA PARKWAY, SUITE 150
 TIGARD, OREGON 97224
 (503)684-0652

1042-08(B)
 SHEET 37 OF 48

104208B140WC

ELIOT TOWER CONDOMINIUMS

BLOCK 246, "CITY OF PORTLAND"
 TOGETHER WITH THE SOUTHERLY 30 FEET OF VACATED SW MADISON STREET,
 SITUATED IN THE NORTHEAST 1/4 OF SECTION 4, TOWNSHIP 1 SOUTH, RANGE 1 EAST,
 WILLAMETTE MERIDIAN, CITY OF PORTLAND, MULTNOMAH COUNTY, OREGON
 MARCH 7, 2006

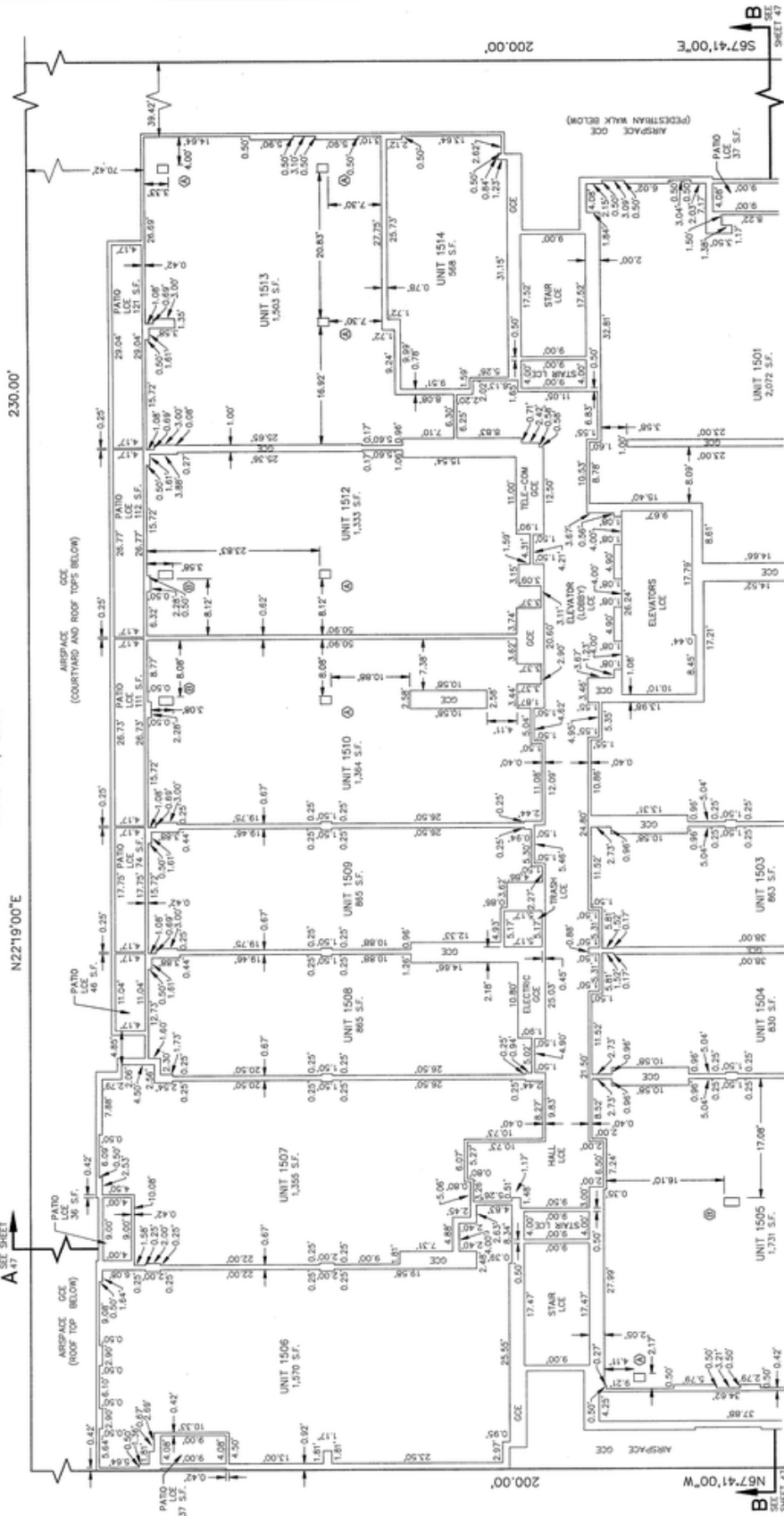

SEE SHEET 39

SEE SHEET 39

LEGEND

- UNIT-## PRIMARY UNIT (RESIDENTIAL)
- GOE GENERAL COMMON ELEMENT
- LCE LIMITED COMMON ELEMENT
- S.F. SQUARE FEET
- COLUMN TYPE

NOTES

1. ALL WALLS ARE PARALLEL, PERPENDICULAR OR AT 45 DEGREES TO THE BOUNDARY LINES SHOWN, UNLESS OTHERWISE NOTED.
2. EXTERIOR THICKNESS SHOWN HEREIN REPRESENT THE DIMENSION FROM THAT APPLICABLE BOUNDARY LINE TO THE INTERIOR WALL SURFACE, UNLESS OTHERWISE NOTED.
3. ALL PRIMARY UNIT DIMENSIONS SHOWN ARE TO THE FACE OF STUD OF THE WALL OR SURFACE OF CONCRETE WALLS AND COLUMNS.
4. AREAS UNLABELED ARE GOE.

COLUMN TYPE DETAIL



SCALE: 1" = 10'

SEE SHEET 39

SEE SHEET 39

SEE SHEET 39

SEE SHEET 39

SEE SHEET 39

REGISTERED PROFESSIONAL LAND SURVEYOR

15TH FLOOR - WEST

I HEREBY CERTIFY THIS TO BE A TRUE AND EXACT COPY OF THE ORIGINAL PLAT

SURVEYED BY:
 WESTLAKE CONSULTANTS, INC.
 15300 S. SEASIDE PARKWAY, SUITE 150
 TIGARD, OREGON 97224
 (503) 684-0652

RENEWAL DATE
 12-31-07

1042-08(B)

SHEET 38 OF 48

10420R15.DWG

ELIOT TOWER CONDOMINIUMS

BLOCK 246, "CITY OF PORTLAND"
 TOGETHER WITH THE SOUTHERLY 30 FEET OF VACATED SW MADISON STREET,
 SITUATED IN THE NORTHEAST 1/4 OF SECTION 4, TOWNSHIP 1 SOUTH, RANGE 1 EAST,
 WILLAMETTE MERIDIAN, CITY OF PORTLAND, MULTNOMAH COUNTY, OREGON
 MARCH 7, 2006

SEE SHEET 38

SEE SHEET 38

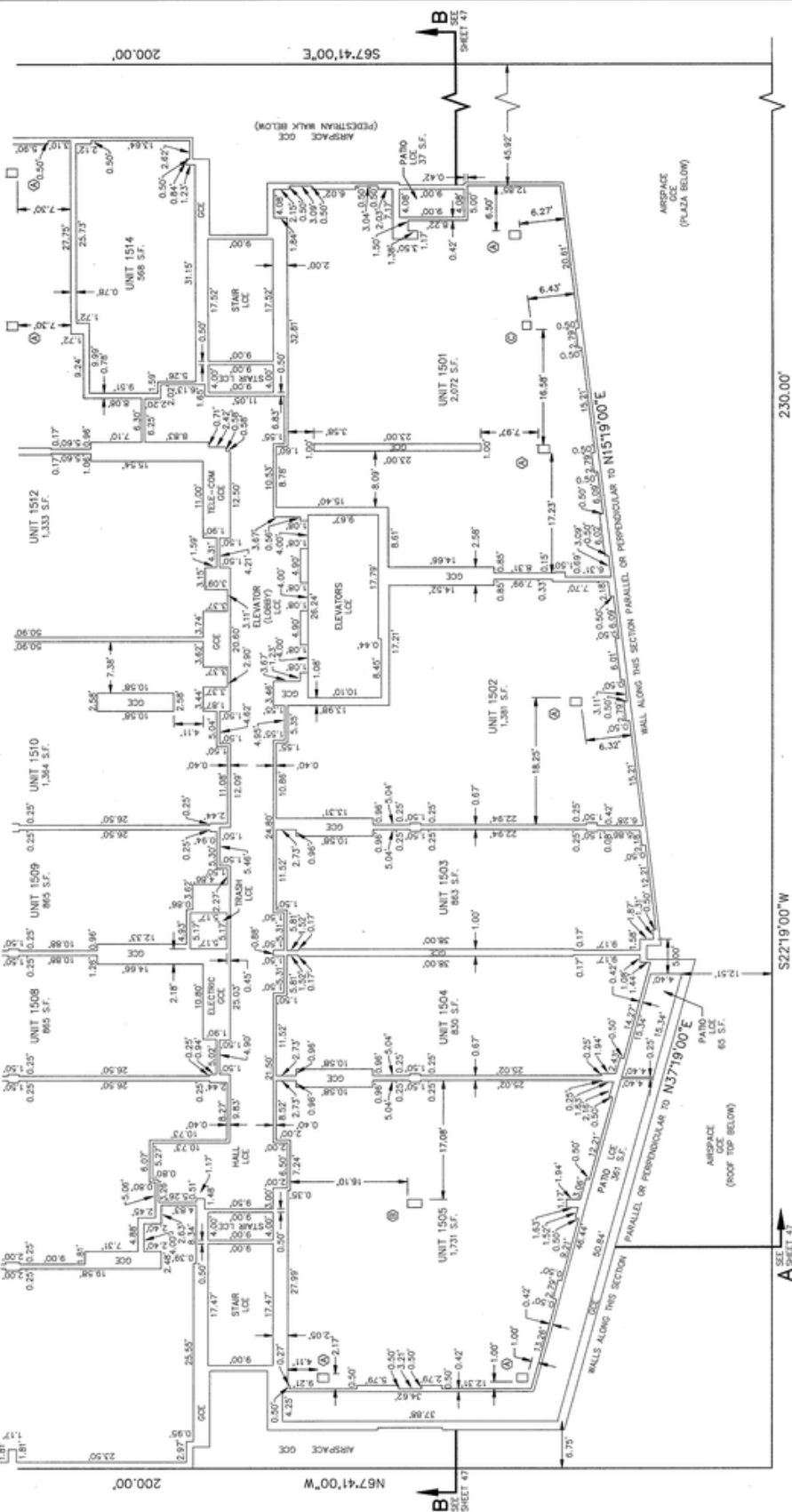

15TH FLOOR—EAST

I HEREBY CERTIFY THIS TO BE A TRUE AND EXACT COPY OF THE ORIGINAL PLAT

REGISTERED PROFESSIONAL LAND SURVEYOR
 GARY R. ANDERSON P.L.S. NO. 2434
 OREGON
 JULY 25, 1990
 GARY R. ANDERSON 2434

SURVEYED BY:
 WESTLAKE CONSULTANTS, INC.
 15115 S.W. SECUCIA PARKWAY, SUITE 150
 HIGARD, OREGON 97224
 (503)984-0652

104208715.DWG

LEGEND

- UNIT-## PRIMARY UNIT (RESIDENTIAL)
- OCZ GENERAL COMMON ELEMENT
- S.F. SQUARE FEET
- COLUMN TYPE

NOTES

1. ALL WALLS ARE PARALLEL, PERPENDICULAR OR AT 45 DEGREES TO THE BOUNDARY LINES SHOWN, UNLESS OTHERWISE NOTED.
2. EXTERIOR THICKNESS SHOWN HEREON REPRESENTS THE DIMENSION FROM THAT APPLICABLE BOUNDARY LINE TO THE INTERIOR WALL SURFACE, UNLESS OTHERWISE NOTED.
3. ALL PRIMARY UNIT DIMENSIONS SHOWN ARE TO THE FACE OF STUD OF THE WALL OR SURFACE OF CONCRETE WALLS AND COLUMNS.
4. AREAS UNLABELED ARE OCZ.

COLUMN TYPE DETAIL



SCALE: 1" = 10'

12-31-07

RENEWAL DATE

1042-08(B)

SHEET 39 OF 48

ELIOT TOWER CONDOMINIUMS

BLOCK 246, "CITY OF PORTLAND"
 TOGETHER WITH THE SOUTHERLY 30 FEET OF VACATED SW MADISON STREET,
 SITUATED IN THE NORTHEAST 1/4 OF SECTION 4, TOWNSHIP 1 EAST,
 WILLAMETTE MERIDIAN, CITY OF PORTLAND, MULTNOMAH COUNTY, OREGON
 MARCH 7, 2006

SEE SHEET 40

SEE SHEET 40

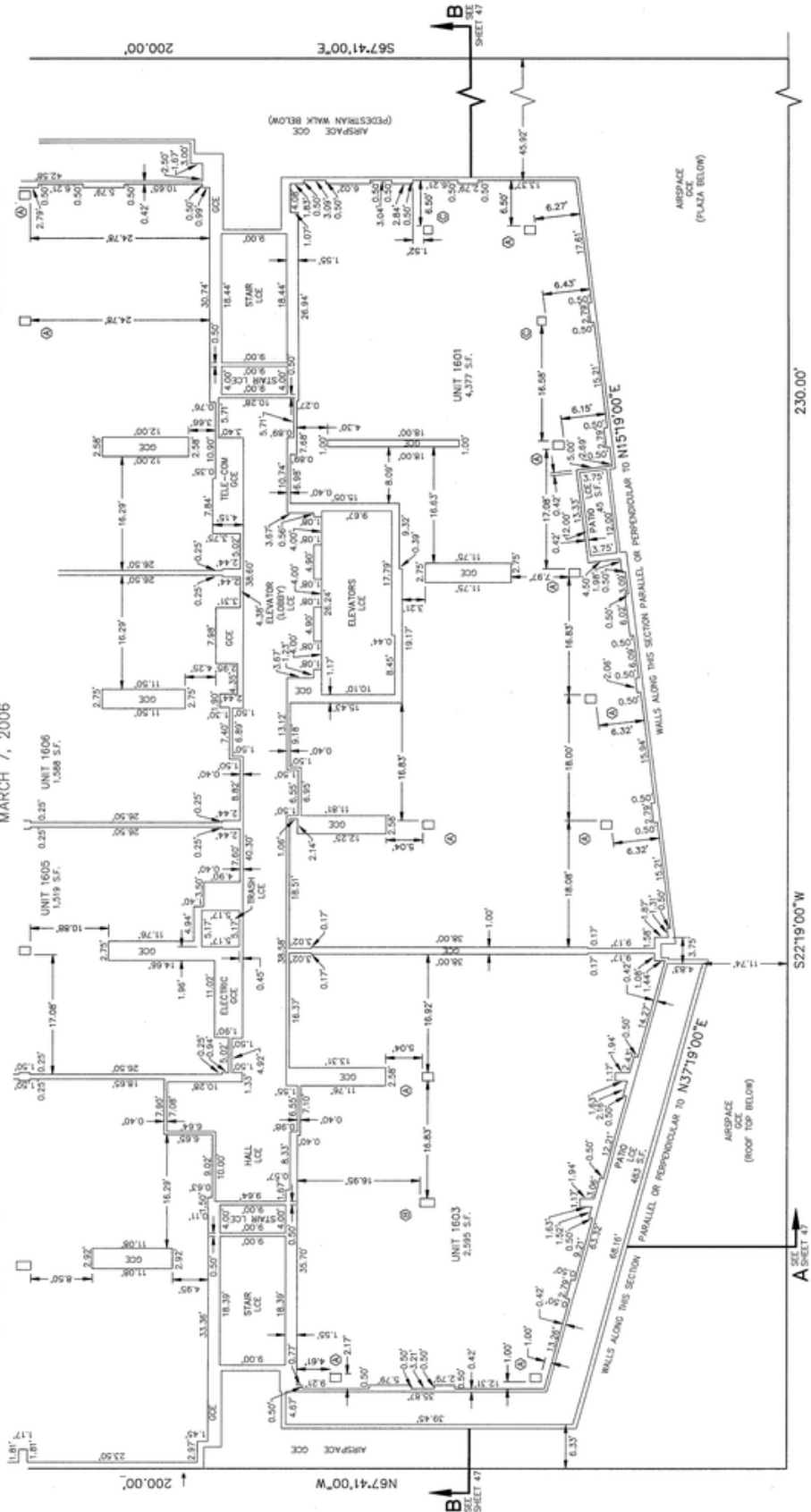

16TH FLOOR-EAST

I HEREBY CERTIFY THIS TO BE A TRUE AND
 EXACT COPY OF THE ORIGINAL PLAT
 GARY R. ANDERSON P.L.S. NO. 2404



SURVEYED BY:
 WESTLAKE CONSULTANTS, INC.
 1015 S. BOGARD AVENUE, SUITE 150
 TOLSON, OREGON 97224
 (503)864-0662

1042-08(B) SHEET 41 OF 48

LEGEND

- UNIT-## PRIMARY UNIT (RESIDENTIAL)
- OCCE GENERAL COMMON ELEMENT
- LOCE LIMITED COMMON ELEMENT
- S.F. SQUARE FEET
- O COLUMN TYPE

NOTES

1. ALL WALLS ARE PARALLEL, PERPENDICULAR OR AT 45 DEGREES TO THE BOUNDARY LINES SHOWN, UNLESS OTHERWISE NOTED.
2. EXTERIOR THICKNESS SHOWN HEREON REPRESENT THE DIMENSION FROM THAT APPLICABLE BOUNDARY LINE TO THE INTERIOR WALL SURFACE, UNLESS OTHERWISE NOTED.
3. ALL PRIMARY UNIT DIMENSIONS SHOWN ARE TO THE FACE OF STUD OF THE WALL OR SURFACE OF CONCRETE WALLS AND COLUMNS.
4. AREAS UNLABELED ARE OCCE.

COLUMN TYPE DETAIL

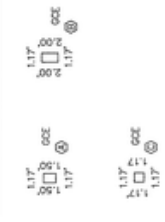

SCALE: 1" = 10'

BLOCK 246, "CITY OF PORTLAND"
 TOGETHER WITH THE SOUTHERLY 30 FEET OF VACATED SW MADISON STREET,
 SITUATED IN THE NORTHEAST 1/4 OF SECTION 4, TOWNSHIP 1 SOUTH, RANGE 1 EAST,
 WILLAMETTE MERIDIAN, CITY OF PORTLAND, MULTNOMAH COUNTY, OREGON
 MARCH 7, 2006

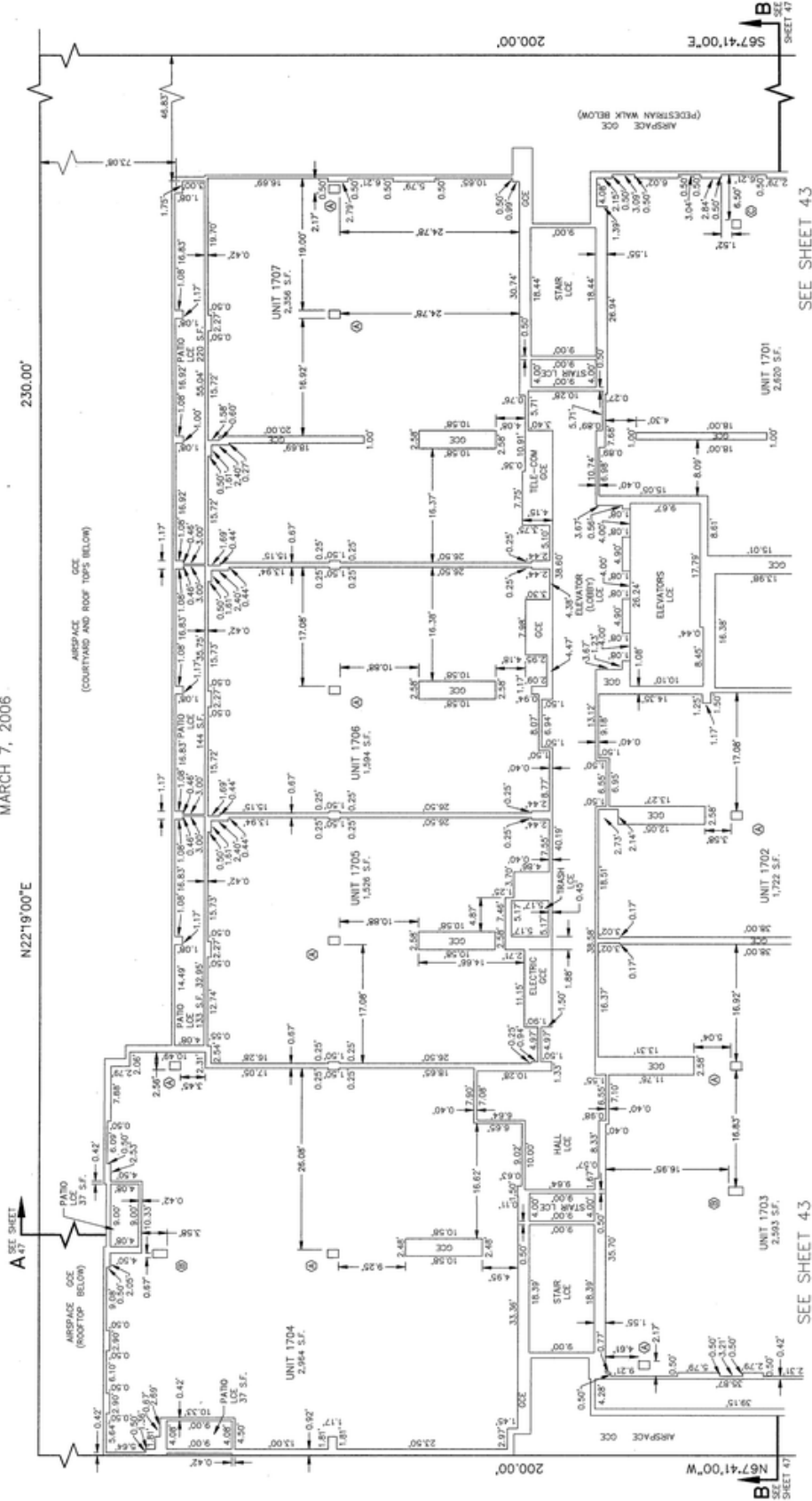

17TH FLOOR—WEST

I HEREBY CERTIFY THIS TO BE A TRUE AND EXACT COPY OF THE ORIGINAL PLAT

REGISTERED PROFESSIONAL LAND SURVEYOR
 GARY R. ANDERSON
 OREGON
 JULY 25, 1999
 5424

SURVEYED BY:
 WESTLAKE CONSULTANTS, INC.
 15115 S.W. SECODIA PARKWAY, SUITE 150
 PORTLAND, OREGON 97224
 (503)564-0852

12-31-07
 RENEWAL DATE

1042-08(8)
 SHEET 42 OF 48

LEGEND

- UNIT-## PRIMARY UNIT (RESIDENTIAL)
- OCZ GENERAL COMMON ELEMENT
- LCE LIMITED COMMON ELEMENT
- S.F. SQUARE FEET
- COLUMN TYPE

NOTES

1. ALL WALLS ARE PARALLEL, PERPENDICULAR OR AT 45 DEGREES TO THE BOUNDARY LINES SHOWN, UNLESS OTHERWISE NOTED.
2. EXTERIOR THICKNESS SHOWN HEREON REPRESENT THE DIMENSION FROM THAT APPLICABLE BOUNDARY LINE TO THE INTERIOR WALL SURFACE, UNLESS OTHERWISE NOTED.
3. ALL PRIMARY UNIT DIMENSIONS SHOWN ARE TO THE FACE OF STUD OF THE WALL, OR SURFACE OF CONCRETE WALLS AND COLUMNS.
4. AREAS UNLABELED ARE OCZ.

COLUMN TYPE DETAIL

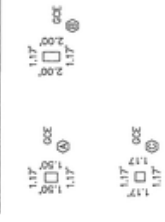

SCALE: 1" = 10'



SEE SHEET 4.3

SEE SHEET 4.3

10420877.DWG

ELIOT TOWER CONDOMINIUMS

BLOCK 246, "CITY OF PORTLAND"
 TOGETHER WITH THE SOUTHERLY 30 FEET OF VACATED SW MADISON STREET,
 SITUATED IN THE NORTHEAST 1/4 OF SECTION 4, TOWNSHIP 1 SOUTH, RANGE 1 EAST,
 WILLAMETTE MERIDIAN, CITY OF PORTLAND, MULTNOMAH COUNTY, OREGON
 MARCH 7, 2006

SEE SHEET 42

SEE SHEET 42

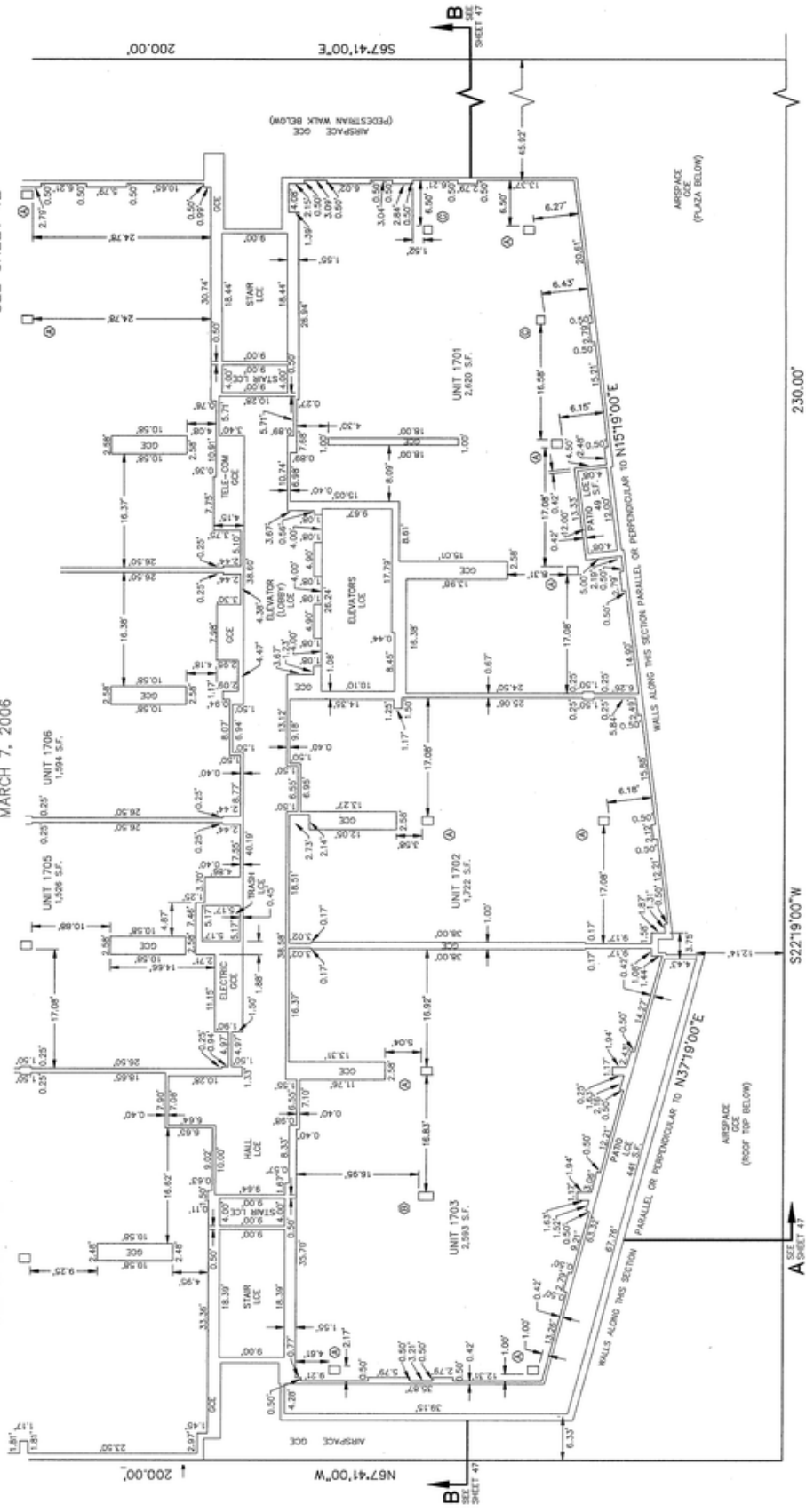

17TH FLOOR—EAST

LEGEND

NOTES

COLUMN TYPE DETAIL

I HEREBY CERTIFY THIS TO BE A TRUE AND EXACT COPY OF THE ORIGINAL PLAT
 GARY R. ANDERSON P.L.S. NO. 2434
 SURVEYED BY:
 WESTLAKE CONSULTANTS, INC.
 15115 S.W. SECODIA PARKWAY, SUITE 150
 TIGARD, OREGON 97224
 (503)864-0652

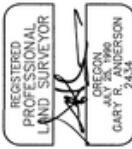

- UNIT—## PRIMARY UNIT (RESIDENTIAL)
- GENERAL COMMON ELEMENT
- LIMITED COMMON ELEMENT
- SQUARE FEET
- COLUMN TYPE

1. ALL WALLS ARE PARALLEL, PERPENDICULAR OR AT 45 DEGREES TO THE BOUNDARY LINES SHOWN, UNLESS OTHERWISE NOTED.
2. EXTERIOR THICKNESS SHOWN HEREIN REPRESENT THE DIMENSION FROM THAT APPLICABLE BOUNDARY LINE TO THE INTERIOR WALL SURFACE, UNLESS OTHERWISE NOTED.
3. ALL PRIMARY UNIT DIMENSIONS SHOWN ARE TO THE FACE OF STUO OF THE WALL OR SURFACE OF CONCRETE WALLS AND COLUMNS.
4. AREAS UNLABELED ARE OCE.

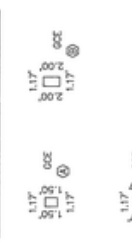

SCALE: 1" = 10'

RENEWAL DATE 12-31-07

1042-08(B)

SHEET 43 OF 48

104208F17.DWG

ELIOT TOWER CONDOMINIUMS

PLAT BOOK 1275 PAGE 58

BLOCK 246, "CITY OF PORTLAND"
 TOGETHER WITH THE SOUTHERLY 30 FEET OF VACATED SW MADISON STREET,
 SITUATED IN THE NORTHEAST 1/4 OF SECTION 4, TOWNSHIP 1 SOUTH, RANGE 1 EAST,
 WILLAMETTE MERIDIAN, CITY OF PORTLAND, MULTNOMAH COUNTY, OREGON
 MARCH 7, 2006

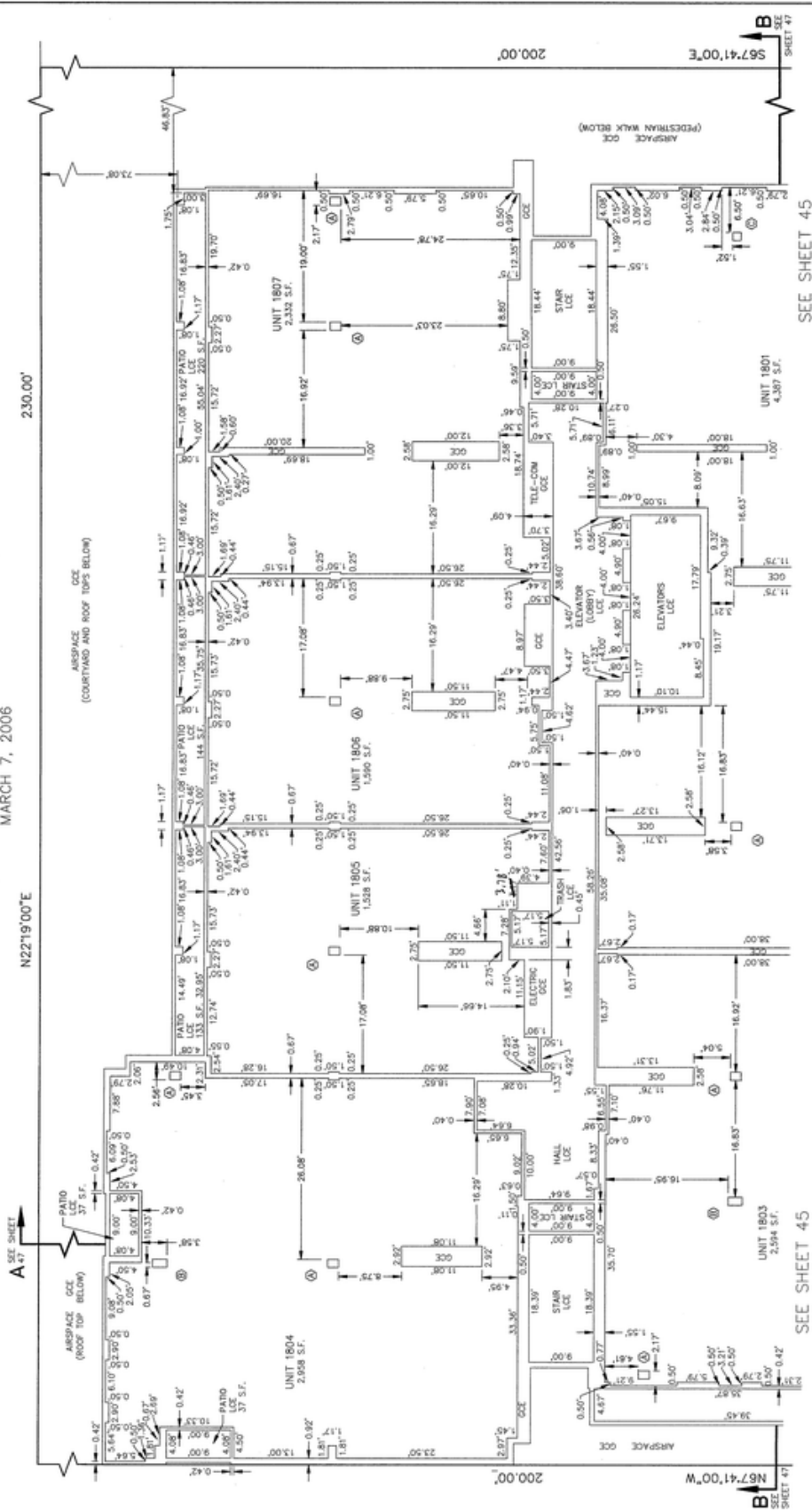

18TH FLOOR-WEST
 I HEREBY CERTIFY THIS TO BE A TRUE AND
 EXACT COPY OF THE ORIGINAL PLAT
 GARY R. ANDERSON P.L.L.C. NO. 2434

REGISTERED
 PROFESSIONAL
 LAND SURVEYOR
 OREGON
 GARY R. ANDERSON
 2434

LEGEND
 UNIT-## PRIMARY UNIT (RESIDENTIAL)
 OCE GENERAL COMMON ELEMENT
 LCE COMMON ELEMENT
 SF SQUARE FEET
 O COLUMN TYPE

NOTES
 1. ALL WALLS ARE PARALLEL, PERPENDICULAR OR AT 45 DEGREES TO THE BOUNDARY LINES SHOWN, UNLESS OTHERWISE NOTED.
 2. EXTERIOR FINISHES SHOWN PERIODICALLY TO INDICATE THE FINISH FROM THAT APPLICABLE BOUNDARY LINE TO THE INTERIOR WALL SURFACE, UNLESS OTHERWISE NOTED.
 3. ALL PRIMARY UNIT DIMENSIONS SHOWN ARE TO THE FACE OF STUD OF THE WALL OR SURFACE OF CONCRETE WALLS AND COLUMNS.
 4. AREAS UNLABLED ARE OCE.

COLUMN TYPE DETAIL
 1.17' OCE
 1.17' OCE
 1.17' OCE
 1.17' OCE

SCALE: 1" = 10'
 1.17' OCE
 1.17' OCE

SEE SHEET 45

SEE SHEET 45

SEE SHEET 45

SEE SHEET 45

SEE SHEET 45

SEE SHEET 45

104208F18.DWG

RENEWAL DATE

12-31-07

1942-08(B)

SHEET 44 OF 48

ELIOT TOWER CONDOMINIUMS

BLOCK 246, "CITY OF PORTLAND"
 TOGETHER WITH THE SOUTHERLY 30 FEET OF VACATED SW MADISON STREET,
 SITUATED IN THE NORTHEAST 1/4 OF SECTION 4, TOWNSHIP 1 SOUTH, RANGE 1 EAST,
 WILLAMETTE MERIDIAN, CITY OF PORTLAND, MULTNOMAH COUNTY, OREGON
 MARCH 7, 2006

SEE SHEET 44

SEE SHEET 44

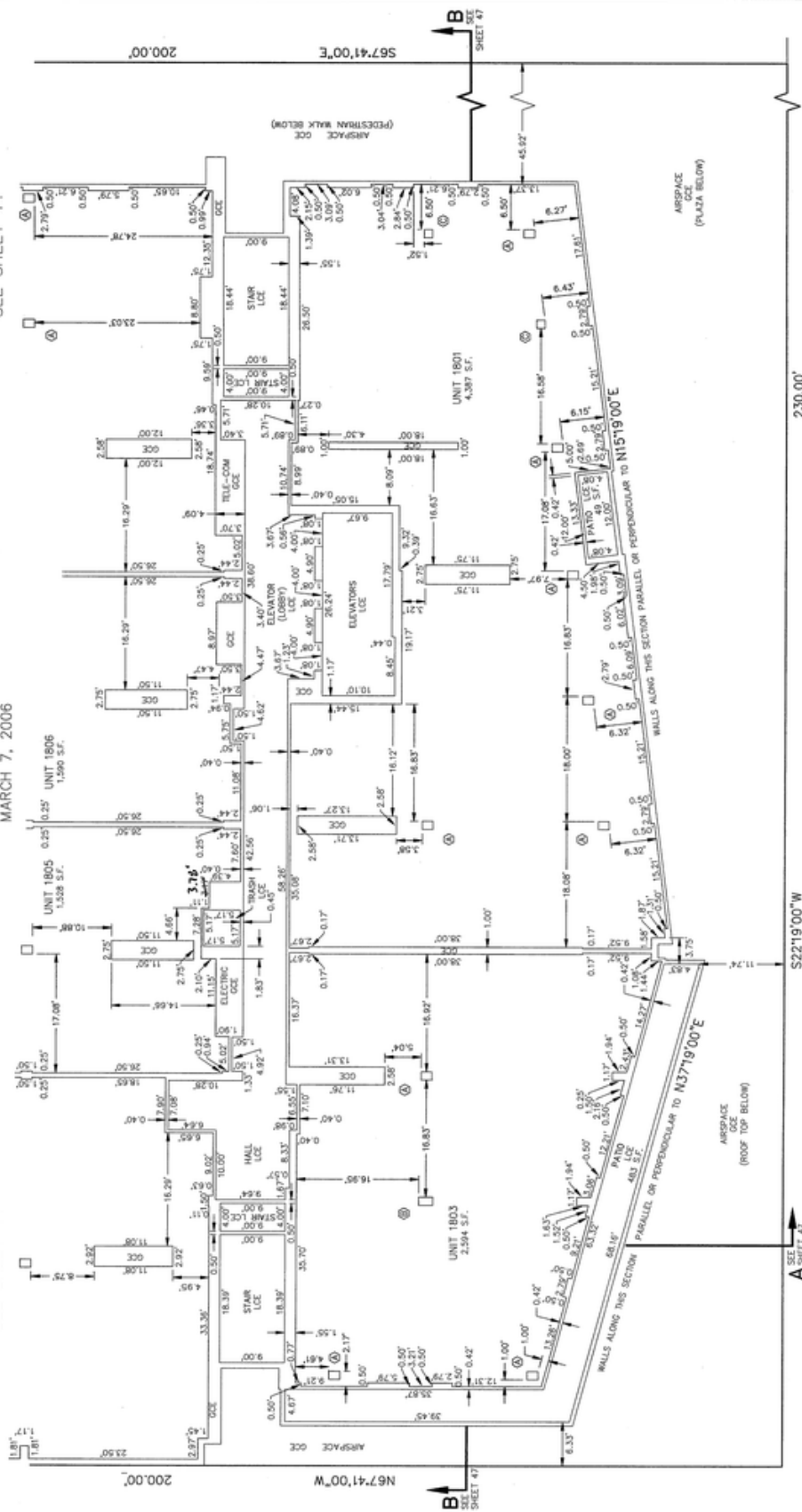

18TH FLOOR-EAST

I HEREBY CERTIFY THIS TO BE A TRUE AND EXACT COPY OF THE ORIGINAL PLAN

GARY R. ANDERSON P.L.S. NO. 2444

SURVEYED BY:
 WESTLAKE CONSULTANTS, INC.
 15115 S.W. SEQUOIA PARKWAY, SUITE 150
 TIGARD, OREGON 97224
 (503)684-0652

1042-08(B) SHEET 45 OF 48



LEGEND

- UNIT-### PRIMARY UNIT (RESIDENTIAL)
- ###-### SECONDARY UNIT (RESIDENTIAL)
- ###-### GENERAL COMMON ELEMENT
- LCE LIMITED COMMON ELEMENT
- S.F. SQUARE FEET
- (TYP.) TYPICAL MEASUREMENT
- COLUMN TYPE

NOTES

1. ALL WALLS ARE PARALLEL, PERPENDICULAR OR AT 45 DEGREES TO THE BOUNDARY LINES SHOWN, UNLESS OTHERWISE NOTED.
2. EXTERIOR THICKNESS SHOWN SECTION REPRESENT THE DIMENSION FROM THAT APPLICABLE BOUNDARY LINE TO THE EXTERIOR WALL SURFACE, UNLESS OTHERWISE NOTED.
3. ALL PRIMARY UNIT DIMENSIONS SHOWN ARE TO THE FACE OF STUD OF THE WALL OR SURFACE OF CONCRETE WALLS AND COLUMNS.
4. AREAS UNLABELED ARE GCE.

COLUMN TYPE DETAIL



SCALE: 1" = 10'

ELIOT TOWER CONDOMINIUMS

BLOCK 246, "CITY OF PORTLAND"
 TOGETHER WITH THE SOUTHERLY 30 FEET OF VACATED SW MADISON STREET,
 SITUATED IN THE NORTHEAST 1/4 OF SECTION 4, TOWNSHIP 1 SOUTH, RANGE 1 EAST,
 WILLAMETTE MERIDIAN, CITY OF PORTLAND, MULTNOMAH COUNTY, OREGON
 MARCH 7, 2006



SCALE VARIES
 (SEE DETAILS)

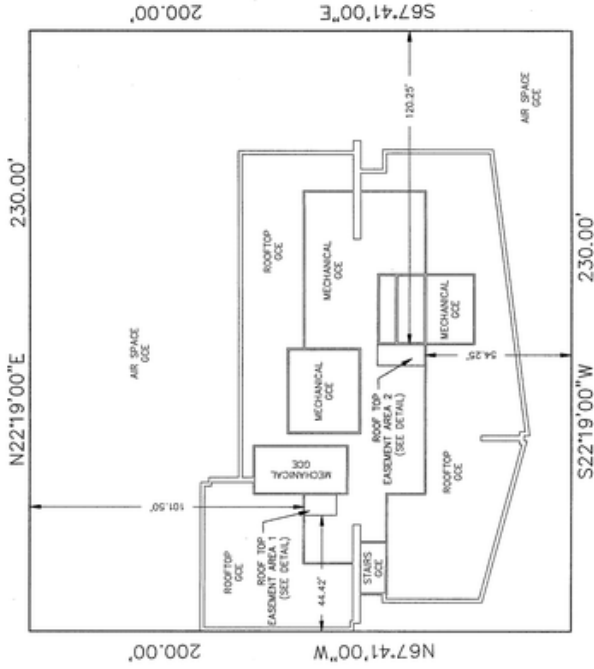
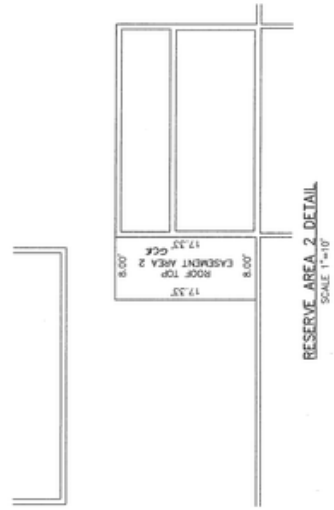
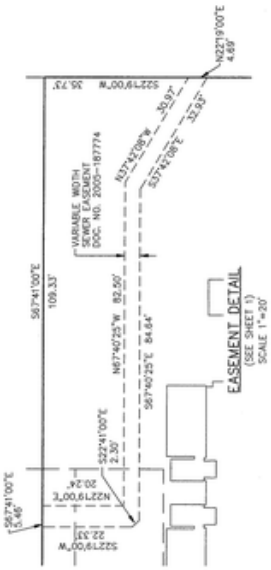

ROOFTOP
 SCALE 1"=30'

LEGEND

- OCE GENERAL COMMON ELEMENT
- LOE LIMITED COMMON ELEMENT

NOTES

- ALL WALLS ARE PARALLEL, PERPENDICULAR OR AT 45 DEGREES TO THE BOUNDARY LINES SHOWN, UNLESS OTHERWISE NOTED.
- AREAS UNLABELED ARE OCE.

I HEREBY CERTIFY THIS TO BE A TRUE AND EXACT COPY OF THE ORIGINAL PLAT

GARY R. ANDERSON P.L.S. NO. 2434

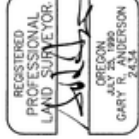

SURVEYED BY:
 WESTLAKE CONSULTANTS, INC.
 15115 S.W. SEQUOIA PARKWAY, SUITE 150
 TIGARD, OREGON 97224
 (503)864-0652

12-31-07
 RENEWAL DATE

1042-08(B)

SHEET 46 OF 48

ELIOT TOWER CONDOMINIUMS

BLOCK 246, "CITY OF PORTLAND"
 TOGETHER WITH THE SOUTHERLY 30 FEET OF VACATED SW MADISON STREET,
 SITUATED IN THE NORTHEAST 1/4 OF SECTION 4, TOWNSHIP 1 SOUTH, RANGE 1 EAST,
 WILLAMETTE MERIDIAN, CITY OF PORTLAND, MULTNOMAH COUNTY, OREGON
 MARCH 7, 2006

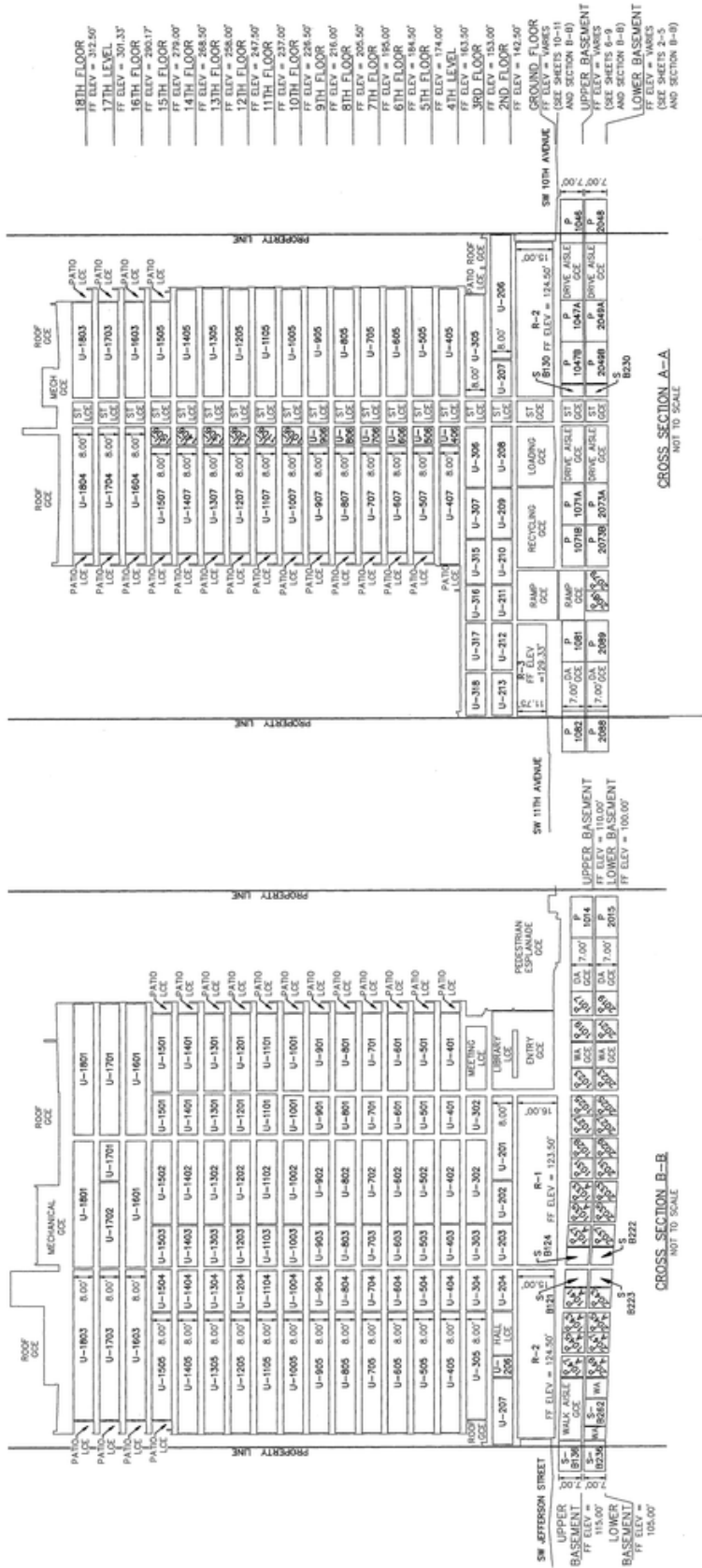

CROSS SECTION A-A
 NOT TO SCALE

CROSS SECTION B-B
 NOT TO SCALE

NOTES
 1. ELEVATIONS ARE BASED ON CITY OF PORTLAND BENCHMARK NO. 2860.
 FOUND 2-1/2" DIAMETER BRASS DISK IN TOP OF CURB AT THE
 CORNER OF SW JEFFERSON ST. AND SW 10TH AVE. ELEVATION = 124.88'
 2. UNIT HEIGHTS ARE TYPICAL (AS DISPLAYED ON CROSS SECTIONS).
 UNLESS NOTED OTHERWISE, SEE SHEETS 2-11 FOR UNITS WHICH ARE NOT
 TYPICAL.

LEGEND
 U-### PRIMARY RESIDENTIAL UNIT NUMBER
 R-### STORAGE UNIT NUMBER
 S-### PARKING UNIT NUMBER
 P-### GENERAL COMMON ELEMENT
 LCE UNITED COMMON ELEMENT

MECH MECHANICAL
 FF ELEV FINISHED FLOOR ELEVATION
 DA DRIVE ASLE
 WA WALK ASLE (OCC. UNO)
 ST STAIRS
 UNO UNLESS NOTED OTHERWISE



REGISTERED PROFESSIONAL LAND SURVEYOR
 GARY R. ANDERSON P.L.S. NO. 2434
 SURVEYED BY:
 WESTLAKE CONSULTANTS, INC.
 15115 S.W. SEQUOIA PARKWAY, SUITE 150
 TIGARD, OREGON 97224
 (503)884-0652

10420R00.0DW

ELIOT TOWER CONDOMINIUMS

BLOCK 246, "CITY OF PORTLAND"
TOGETHER WITH THE SOUTHERLY 30 FEET OF VACATED SW MADISON STREET,
SITUATED IN THE NORTHEAST 1/4 OF SECTION 4, TOWNSHIP 1 SOUTH, RANGE 1 EAST,
WILLAMETTE MERIDIAN, CITY OF PORTLAND, MULTNOMAH COUNTY, OREGON
MARCH 7, 2006

DECLARATION

KNOW ALL PERSONS BY THESE PRESENTS, THAT ELIOT TOWER LLC, AN OREGON LIMITED LIABILITY COMPANY, AS OWNER OF THE LANDS DESCRIBED IN THE ACCOMPANYING SURVEYOR'S CERTIFICATE DOES HEREBY DECLARE THE ANNEXED MAP OF "ELIOT TOWER CONDOMINIUMS" TO BE TRUE AND CORRECT, AND DOES HEREBY COMMIT SAID PROPERTY TO THE OPERATION AND MAINTENANCE OF SAID CONDOMINIUM ACT. THE PROPERTY AND IMPROVEMENTS DESCRIBED AND REFERRED TO HEREIN ARE SUBJECT TO THE PROVISIONS OF OREGON REVISED STATUTES 100.005 TO 100.625.

ELIOT TOWER LLC, AN OREGON LIMITED LIABILITY COMPANY

BY: CARROLL ELIOT DEVELOPMENT SERVICES, LLC,
ITS MANAGING MEMBER
MANAGER

BY: John Carroll MEMBER
AUTHORIZED AGENT

* BY: ELIOT EQUITY INVESTORS LLC, AN OREGON LIMITED LIABILITY COMPANY
ITS MANAGER

ACKNOWLEDGMENT

STATE OF OREGON }
COUNTY OF Multnomah } SS

I DO HEREBY CERTIFY THAT ON THIS 13 DAY OF April 2006 PUBLIC RECORDS FOR MULTNOMAH COUNTY, OREGON, PERSONALLY APPEARED JOHN CARROLL BEING FULLY SENSIBLE AND THAT HE IS THE IDENTICAL PERSON NAMED IN THE FOREGOING INSTRUMENT AND THAT SAID INSTRUMENT WAS EXECUTED BY HIM, AS MANAGING MEMBER, ON BEHALF OF CARROLL ELIOT DEVELOPMENT SERVICES, LLC, MANAGING MEMBER OF ELIOT TOWER LLC, AN OREGON LIMITED LIABILITY COMPANY AND HEREBY ACKNOWLEDGED SAID INSTRUMENT TO BE OF HIS OWN FREE ACT AND DEED, ON BEHALF OF SUCH COMPANIES.

BY: Bill McCorkle
NOTARY SIGNATURE
BILL MC CORKLE
NOTARY PUBLIC FOR OREGON

COMMISSION NO.: 358025
MY COMMISSION EXPIRES: July 06, 2006

APPROVALS

APPROVED THIS 4th DAY OF May 2006
COUNTY SURVEYOR, MULTNOMAH COUNTY, OREGON

BY: Robert A. Hardin

ALL TAXES, FEES, ASSESSMENTS OR OTHER CHARGES AS PROVIDED BY O.R.S. 100.110 HAVE BEEN PAID AS OF May 5 2006
DIRECTOR, DIVISION OF ASSESSMENT AND TAXATION
MULTNOMAH COUNTY, OREGON

BY: J. Brown DEPUTY

STATE OF OREGON }
COUNTY OF MULTNOMAH } SS

I DO HEREBY CERTIFY THAT THE ATTACHED CONDOMINIUM PLAT WAS RECEIVED FOR RECORD AND RECORDED AT 9:13 AM IN BOOK 1275 ON PAGES 5-62 COUNTY RECORDING OFFICE. MAY 5 2006

BY: Robert A. Hardin DEPUTY
DOCUMENT NO. 2006-082513

SURVEYOR'S CERTIFICATE OF COMPLETION

I, GARY R. ANDERSON, A REGISTERED PROFESSIONAL LAND SURVEYOR, HEREBY CERTIFY THAT THE PLAT OF "ELIOT TOWER CONDOMINIUMS" FULLY AND ACCURATELY DEPICTS THE BOUNDARIES OF THE UNITS AND THE BUILDING AND THAT CONSTRUCTION OF THE UNITS AND BUILDING, AS DEPICTED ON SUCH PLAT, HAS BEEN COMPLETED.

DATED THIS 12th DAY OF April 2006

BY: Gary R. Anderson
GARY R. ANDERSON, P.L.S. 2434

NOTE:

THIS PLAT IS SUBJECT TO AN EASEMENT AGREEMENT WITH THE YUCA OF GREATER PORTLAND RECORDED MARCH 6, 2006 AS DOC. NO. 2006-047265 MULTNOMAH COUNTY DEED RECORDS.



I HEREBY CERTIFY THIS TO BE A TRUE AND EXACT COPY OF THE ORIGINAL PLAT

GARY R. ANDERSON P.L.S. NO. 2434
SURVEYED BY:
WESTLAKE CONSULTANTS, INC.
15115 S.W. SEQUOIA PARKWAY, SUITE 150
TIGARD, OREGON 97224
(503)884-0652

12-31-07
RENEWAL DATE

1042-08(B)

SHEET 48 OF 48

Table of Contents

	<u>Page</u>
1. Definitions and Interpretation.....	1
1.1 Definitions.....	1
1.2 Liberal Construction.....	3
1.3 Mortgagee Approval.....	3
1.4 No Fiduciary Standard.....	3
1.5 Original Owner of Units.....	3
1.6 Captions and Exhibits.....	3
1.7 Miscellaneous.....	3
2. Property Submitted.....	3
3. Name.....	3
4. Units.....	4
4.1 General Description of Buildings.....	4
4.2 General Description, Location, and Designation of Units.....	4
4.3 Boundaries of Units.....	5
5. Owner's Interest in Common Elements; General Common Elements.....	6
6. Limited Common Elements.....	6
7. Allocation of Common Profits and Expenses; Enforcement of Assessments.....	7
7.1 Method of Allocation.....	7
7.2 Commencement of Assessments.....	8
7.3 No Exception.....	8
7.4 Default in Payment of Common Expenses.....	8
7.5 Foreclosure of Liens for Unpaid Common Expenses.....	9
7.6 First Mortgages; Liability of Subsequent Purchaser.....	9
8. Voting Rights.....	9
9. Use.....	9
10. Service of Process.....	10
11. Authority Regarding Easements and Other Property Rights.....	10
12. No Restrictions on Alienation.....	10
13. Maintenance and Repairs; Reserve Fund.....	11
13.1 Maintenance of Common Elements and Parking Units.....	11

13.2	Maintenance of Units.....	11
13.3	Reserve Fund for Replacing Common Elements.....	12
14.	Rights of Access and Use; Reservations by Declarant; Special Declarant Rights.....	12
14.1	In General.....	12
14.2	Water Intrusion and Mold Inspection.....	13
14.3	Additional Rights Created by Association.....	13
14.4	Right of Entry.....	13
14.5	Right of Access and Use for Declarant.....	13
14.6	Easement and License Reserved for Declarant.....	14
14.7	YWCA Easement.....	14
14.8	Madison Place Easement.....	14
14.9	Special Declarant Rights.....	14
14.10	Reservation of Unused FAR.....	16
15.	Partition; Division.....	16
15.1	Partition.....	16
15.2	Creating Additional Units from the Retail Units.....	16
16.	Encroachments.....	17
17.	Notices to Mortgagees.....	17
18.	Operating Entity.....	17
19.	Managing Agent.....	18
20.	Taxation of Units.....	18
21.	Administrative Control.....	18
22.	Casualty.....	19
22.1	Responsibility of Association.....	19
22.2	Responsibility of Owner.....	19
23.	Condemnation.....	20
23.1	Total Condemnation.....	20
23.2	Partial Condemnation.....	20
24.	Fidelity Bond.....	20
25.	Amendment.....	20
25.1	Approval by Owners.....	20
25.2	Approval by Mortgagees.....	21
25.3	Approval by Governmental Authorities.....	22
25.4	Recordation.....	22

26.	Termination	22
27.	Dispute Resolution	23
	27.1 Required Procedure	23
	27.2 Negotiated Resolution	23
	27.3 Mediation	23
	27.4 Small Claims.....	24
	27.5 Arbitration.....	24
	27.6 Claims Procedure.....	24
	27.7 Limitations on Actions.....	24
	27.8 Confidentiality	25
	27.9 No Attorneys' Fees.....	25
28.	Waiver; Time Limitation	25
	28.1 RELEASE AND WAIVER OF ALL OTHER PAST, PRESENT, AND FUTURE CLAIMS REGARDING CONDITION OF PROPERTY	25
	28.2 TIME LIMITATION ON ACTIONS.....	26
29.	Severability	27

Exhibits to Declaration

- Exhibit A - Property Description
- Exhibit B - Allocation of Interest in Common Elements
- Exhibit C-1 - Listing of Retail and Residential Expenses
- Exhibit C-2 - Allocation of Retail Expenses
- Exhibit C-3 - Allocation of Residential Expenses
- Exhibit D - Bylaws of Eliot Tower Condominiums Owners' Association

**DECLARATION OF CONDOMINIUM OWNERSHIP FOR
ELIOT TOWER CONDOMINIUMS
MADE PURSUANT TO THE OREGON CONDOMINIUM ACT**

This Declaration, to be effective upon its recording in Multnomah County, Oregon, pursuant to the provisions of the Oregon Condominium Act, is made and executed this 12th day of April, 2006, by Eliot Tower LLC, an Oregon limited liability company ("Declarant").

Declarant proposes to create a condominium located in the City of Portland, Multnomah County, Oregon, to be known as Eliot Tower Condominiums, composed of 232 Primary Units, 279 Parking Units, and 150 Storage Units located in one newly constructed building and associated landscaping. The newly constructed building will consist of eighteen (18) floors above grade and a two-level basement. The purpose of this Declaration is to submit Eliot Tower Condominiums to the condominium form of ownership and use in the manner provided by the Oregon Condominium Act.

1. Definitions and Interpretation.

1.1 Definitions. As used in this Declaration, the Articles of Incorporation of the Eliot Tower Condominiums Owners' Association, its Bylaws, its Rules and Regulations, and any exhibits thereto, unless the context shall otherwise require, the following definitions shall be applied:

1.1.1 Act shall mean the Oregon Condominium Act, currently ORS 100.005 to 100.990, as amended from time to time.

1.1.2 Association shall mean the nonprofit corporate entity responsible for the administration, management and operation of the Condominium.

1.1.3 Association Property shall mean any real property or interest in real property acquired, held, or possessed by the Association pursuant to ORS 100.405.

1.1.4 Board shall mean the Board of Directors of the Association.

1.1.5 Bylaws shall mean the Bylaws of the Association, as amended from time to time.

1.1.6 Common Elements shall mean all those portions of the Condominium exclusive of the Units.

1.1.7 Condominium shall mean the Property that is hereby submitted to condominium ownership and all improvements thereon and all easements and rights appurtenant thereto.

1.1.8 Declaration shall mean this Declaration of Condominium Ownership for Eliot Tower Condominiums and any amendments thereto.

1.1.9 General Common Elements shall mean those Common Elements designated in Section 5.

1.1.10 Legal Requirements shall mean any and all laws, orders, rules, and regulations of any governmental entity.

1.1.11 Limited Common Elements shall mean those Common Elements designated in Section 6.

1.1.12 Mortgage shall include a deed of trust and a contract for the sale of real estate.

1.1.13 Mortgagee shall include a deed of trust beneficiary and a vendor under a contract for the sale of real estate.

1.1.14 Owner shall mean the owner or owners of a Unit, but shall not include a Mortgagee unless in possession of a Unit. A person or entity who does not own a Unit shall not be an Owner.

1.1.15 Parking Unit shall mean that part of the Condominium designated as such in Section 4 and comprised of the space enclosed by its boundaries as described in Section 4.

1.1.16 Plans shall mean the plat for the Condominium which is being recorded in the deed records of Multnomah County, Oregon, concurrently with this Declaration and any revisions of such plat subsequently recorded.

1.1.17 Primary Unit shall mean the part of the Condominium designated as either a Residential Unit or a Retail Unit. The Retail Units and Residential Units are referred to collectively herein as the "Primary Units."

1.1.18 Property shall mean the property submitted to the provisions of the Act, as described more particularly in Section 2.

1.1.19 Rules and Regulations shall mean those rules and regulations governing the use and enjoyment of the Condominium, as adopted by the Board pursuant to the Bylaws.

1.1.20 Storage Unit shall mean the part of the Condominium designated as such in Section 4 and comprised of the space enclosed by its boundaries as described in Section 4.

1.1.21 Turnover Meeting shall mean the meeting at which Declarant relinquishes control of the administration of the Association pursuant to Section 100.210 of the Act.

1.1.22 Units shall mean those parts of the Condominium designated in Section 4 as Primary Units and comprised of the spaces enclosed by each of their respective boundaries as described in Section 4; Unit shall mean any one of the Units.

1.2 Liberal Construction. The provisions of this Declaration shall be liberally construed to effectuate its purpose of creating a uniform plan for the development and operation of the Condominium under the provisions of Oregon law. The terms used herein are intended to have the same meaning as may be given in the Act to such terms unless the context clearly requires otherwise or definition in this manner would have an unlawful consequence.

1.3 Mortgagee Approval. For purposes of determining the percentage of first Mortgagees approving a proposed decision or course of action in cases where a Mortgagee holds first Mortgages on more than one Primary Unit, such Mortgagee shall be deemed a separate Mortgagee as to each such Primary Unit.

1.4 No Fiduciary Standard. In no event shall Declarant be deemed to be a fiduciary of the Owners or be held to a fiduciary standard with respect to activities hereunder. The foregoing language does not apply to fiduciary responsibilities officers or directors of the Association may otherwise have.

1.5 Original Owner of Units. Declarant is the original Owner of all Units and will continue to be deemed the Owner of each Unit until conveyances or other documents changing the ownership of specifically described Units are filed of record.

1.6 Captions and Exhibits. The captions given herein are for convenience only and are not intended to modify or affect the meaning of any of the substantive provisions hereof. The various exhibits referred to herein and attached hereto shall be deemed incorporated herein by reference as though fully set forth where such reference is made.

1.7 Miscellaneous. All terms and words used in this Declaration, regardless of the number or gender in which they are used, shall be deemed to include any other number and any other gender as the context may require. "And/or" when applied to two or more matters or things shall be construed to apply to any one or more or all thereof, as the circumstances then warrant. "Herein," "hereof," "hereunder," and words of similar import shall be construed to refer to this Declaration as a whole, and not to any particular section, unless expressly stated otherwise.

2. Property Submitted. The Property hereby submitted to the provisions of the Act is the land owned in fee simple by Declarant and described on the attached Exhibit A, together with all easements, rights, and appurtenances belonging thereto and all improvements now existing or hereafter constructed on such land and excluding ownership of the unused floor area ratio as provided in Section 14.10.

3. Name. The name by which the Property is to be identified is "Eliot Tower Condominiums."

4. Units.

4.1 General Description of Buildings. The Condominium shall consist of one newly constructed building of cast concrete construction. The building has eighteen (18) floors above grade and a two-level basement.

4.2 General Description, Location, and Designation of Units. The Condominium consists of a total of 232 Primary Units, 279 Parking Units, and 150 Storage Units located on a generally level site as shown on the Plans. The Primary Units will be designated for residential or retail use in accordance with Section 9 below. The Primary Units to be designated in Section 9 for retail use will be located on the ground floor of the building (the "Retail Units"). The Retail Units are designated as R1, R2, and R3, as shown on the Plans. The Primary Units to be designated for residential use will be located on the first through eighteenth floors of the building (the "Residential Units"). The Parking Units are located in the basement levels. The Storage Units are located in the basement and on the first and the second floors. The Residential Units are designated as Units 101 through 110, inclusive, located on the first floor of the building, Units 201 through 220, inclusive, located on the second floor of the building, Units 302 through 318, inclusive, located on the third floor of the building; Units 401 through 414, inclusive, located on the fourth floor of the building; Units 501 through 514, inclusive, located on the fifth floor of the building; Units 601 through 614, inclusive, located on the sixth floor of the building; Units 701 through 714, inclusive, located on the seventh floor of the building; Units 801 through 814, inclusive, located on the eighth floor of the building; Units 901 through 914, inclusive, located on the ninth floor of the building; Units 1001 through 1014, inclusive, located on the tenth floor of the building; Units 1101 through 1110, inclusive, and 1112 through 1114, inclusive, located on the eleventh floor of the building; Units 1201 through 1210, inclusive, and 1212 through 1214, inclusive, located on the twelfth floor of the building; Units 1301 through 1310, inclusive, and 1312 through 1314, inclusive, located on the thirteenth floor of the building; Units 1401 through 1410, inclusive, and 1412 through 1414, inclusive, located on the fourteenth floor of the building; Units 1501 through 1510, inclusive, and 1512 through 1514, inclusive, located on the fifteenth floor of the building; Units 1601 and 1603 through 1607, inclusive, located on the sixteenth floor of the building; Units 1701 through 1707, inclusive, located on the seventeenth floor of the building; and Units 1801 and 1803 through 1807, inclusive, located on the eighteenth floor of the building. The Storage Units shall be designated as S-B103 through S-B118, inclusive, S-B120 through S-B140, inclusive, S-B142, S-B145 through S-B148, inclusive, S-B151, inclusive, S-B203 through S-B248, inclusive, S-B250, S-B251, S-B254, S-B260 through S-B263, inclusive, S-121 through S-143, inclusive, S-160, S-161, S-222 through S-225, inclusive, S-227, S-229 through S-236, inclusive, S-238 through S-245, inclusive, S-249 through S-255, inclusive, S-280 and S-281, as shown on the Plans. The Parking Units shall be designated as P-1001 through P-1032, P-1033A, P-1033B, P-1034, P-1035A, P-1035B, P-1036, P-1037A, P-1037B, P-1038 through P-1040, inclusive, P-1041A, P-1041B, P-1042, P-1043A, P-1043B, P-1044, P-1045A, P-1045B, P-1046, P-1047A, P-1047B, P-1048 through P-1055, inclusive, P-1056A, P-1056B, P-1057A, P-1057B, P-1058, P-1059A, P-1059B, P-1060, P-1061A, P-1061B, P-1062, P-1063A, P-1063B, P-1064A, P-1064B, P-1065A, P-1065B, P-1066, P-1067A, P-1067B, P-1068, P-1069A, P-1069B, P-1070A, P-1070B, P-1071A, P-1071B, P-1072 through P-1117, inclusive, P-2001 through P-2044, inclusive, P-2045A, P-2045B, P-2046, P-2047A, P-2047B, P-2048, P-2049A, P-2049B, P-2050 through P-2057, inclusive, P-2058A, P-2058B, P-2059A, P-

2059B, P-2060A, P-2060B, P-2061A, P-2061B, P-2062A, P-2062B, P-2063A, P-2063B, P-2064A, P-2064B, P-2065A, P-2065B, P-2066A, P-2066B, P-2067A, P-2067B, P-2068, P-2069A, P-2069B, P-2070A, P-2070B, P-2071A, P-2071B, P-2072A, P-2072B, P-2073A, P-2073B, P-2074 through P-2126. Parking Units P-1001 through P-1117 are located in the first basement parking level of the building, and Parking Units P-2001 through P-2126 are located on the second basement parking level of the building. The square footage of the Units is set forth on the attached Exhibit B and as shown on the Plans.

4.3 Boundaries of Units.

4.3.1 Primary Units. The Primary Units shall be bounded as follows:

(a) Each Residential Unit shall be bounded by the interior surfaces of its perimeter and demising stud walls, including the surface of any concrete perimeter or demising wall, floors, ceilings, windows and window frames, doors and door frames, and trim, and shall include both the interior surfaces so described (including the unexposed face of the sheetrock or similar material and the underside of the finished floor and any other materials constituting any part of its finished surfaces) and the air space so encompassed. In addition, Residential Units with a fireplace shall include the fireplace box within such Residential Unit's boundaries as described above, but shall exclude the vertical chase for serving such fireplace. Each Residential Unit with a second floor shall also include the stairwell between the first and second floors of such Unit, which is located within the foregoing boundaries of each such Residential Unit.

(b) The Retail Units shall be bounded by the interior surfaces of the exterior perimeter walls of the building, the interior demising walls that bound Common Element areas, as shown on the Plans, floors, ceilings, windows and window frames and doors and door frames located in the exterior perimeter walls or interior demising walls that bound Common Element areas, and perimeter trim, and shall include both the interior surfaces so described (including the unexposed face of the sheetrock of such walls or similar material and the underside of the finished floor, if any) and the air space so encompassed, without regard to intervening demising walls, and shall include all areas so described on the ground level as shown on the Plans.

In addition, each Primary Unit shall include the outlet of any utility service lines, including water, sewer, electricity, or cable television, and of ventilating or air conditioning ducts, but shall not include any part of such lines or ducts themselves.

4.3.2 Parking Units. Each Unit identified on the Plans as a parking unit (a "Parking Unit") shall consist of the paved surface of the Parking Unit, a vertical plane extending upwards at a 90° angle from the boundaries of the paved surface of the Parking Unit, and a horizontal plane coextensive with the boundaries of the paved surface of the Parking Unit, and a horizontal plane coextensive with the boundaries formed by the uppermost edge of each vertical plane, as shown on the Plans. The height of such horizontal plane may vary in some Parking Units, due to the existence of or reservation of space for the installation of mechanical equipment above such Parking Units. Regardless of the actual location of the painted striping

for Parking Units, the boundaries of the Parking Units shall be as set forth herein and on the Plans. Parking Units do not include the floor, ceiling or perimeter walls.

4.3.3 Storage Units. Each Unit identified on the Plans as a storage unit (a "Storage Unit") shall be bounded by (i) the interior surfaces of its doorway or face panel, including any fixtures thereon or attached thereto, such as knobs, handles, and hinges and (ii) the interior surfaces of the side and back walls (or side and back panels), floor (or bottom panel), and ceiling (or top panel) of each Storage Unit, and shall include the air space so encompassed.

5. Owner's Interest in Common Elements; General Common Elements. Each Owner shall be entitled to an undivided percentage ownership interest in the Common Elements, as shown on the Plans and the table attached as Exhibit B. The method used to establish this allocation consists of (i) an allocation of an 0.01 percent undivided interest to each of the Parking Units and Storage Units, and (ii) an allocation of the remaining undivided interests to the Primary Units determined by the ratio which the area of each Primary Unit bears to the total area of all Primary Units combined, as shown on the Plans. The general location of the Common Elements is shown on the Plans. The General Common Elements shall consist of all parts of the Condominium other than the Units and the Limited Common Elements and include, without limitation, the following:

5.1 All floor slabs; common corridors (except as specified in Section 6); stairwells (except as specified in Sections 4 and 6); elevators (except as specified in Sections 4 and 6); vestibules, drive aisles in parking areas; mechanical rooms; electrical room; water room; foundations; exterior windows; crawl spaces; roofs (except as specified in Section 6); columns; beams; girders; supports; and bearing walls.

5.2 Pipes, ducts, conduits, wires, and other utility installations, in each case to their respective outlets.

5.3 The recycling/trash room and loading area on the ground floor, as shown on the Plans.

5.4 Landscaping, ground level plaza and exterior walkways.

5.5 The lobby located on the ground floor, including the concierge desk and office area and adjoining bathroom.

5.6 The land included in the Property, together with any rights or appurtenances related thereto.

5.7 All other elements of the Condominium necessary or convenient to its existence, maintenance, or safety, or normally in common use, except as may be expressly designated herein as a part of a Unit or a Limited Common Element.

6. Limited Common Elements. The Limited Common Elements shall consist of (i) the ground level gated courtyard, the use of which is reserved for the Owners and occupants of Residential Units, as shown on the Plans; (ii) common corridors located in the first through

eighteenth floors of the building, the use of which is reserved on an equal and exclusive basis for the Owners of Residential Units, as shown on the Plans; (iii) the elevator and stairwells located on from the 2nd through the 18th floors of the building, the use of which is reserved on an exclusive basis for Owners and occupants of the Residential Units; (iv) mail area located on the ground floor of the building, as shown on the Plans, the use of which is reserved on an exclusive basis for the Residential Unit Owners and occupants; (v) outdoor patios adjacent to certain Residential Units, as shown on the Plans, the use of which is reserved on an exclusive basis for the Owner of the adjacent Residential Unit; (vi) rooms located on the second through eighteenth floors of the building in which the residential trash chute is located, as shown on the Plans, the use of which is reserved on an equal and exclusive basis for the Owners and occupants of Residential Units; (vii) the library, exercise rooms and bathrooms located on the second floor, the use of which is reserved on an equal and exclusive basis for the Owners and occupants of Residential Units, as shown on the Plans; (viii) the meeting room located on the third floor, the use of which is reserved on an equal and exclusive basis for the Owners and occupants of the Residential Units, as shown on the Plans; and (ix) the outdoor patio and adjoining indoor kitchen located on the third floor, as shown on the Plans, the use of which is reserved on an equal and exclusive basis for the Owners and occupants of Residential Units. The dimensions, designation, and location of the Limited Common Elements are shown on the Plans.

7. Allocation of Common Profits and Expenses; Enforcement of Assessments.

7.1 Method of Allocation. The common profits of the Property shall be distributed among the Owners according to the percentage of each Owner's respective undivided interest in the Common Elements pertaining to their Primary Units, without regard to any interest in the Common Elements pertaining to their Parking or Storage Units. The common expenses of the Property shall be divided into retail expenses, including any reserve assessments allocated to the Owners of the Retail Units pursuant to Section 5.2 of the Bylaws (the "Retail Expenses"), as shown on the attached Exhibit C-1; and residential expenses, including any reserve assessments allocated to Owners of Residential Units pursuant to Section 5.2 of the Bylaws (the "Residential Expenses"), as shown on the attached Exhibit C-1. The Retail Expenses shall be charged to the Owners of the Retail Units according to the percentage determined by the ratio which the area of each Retail Unit bears to the total area of all Retail Units, as shown on the attached Exhibit C-2. The Residential Expenses shall be charged to the Owners of the Residential Units according to the percentage determined by the ratio which the area of each Residential Unit and the Limited Common Element patio adjoining such Unit, if any, bears to the total area of all Residential Units and Limited Common Element patios, as shown on the attached Exhibit C-3. In the event an Owner of a Primary Unit shall use an unreasonably disproportionate amount of a service included in the common expenses, as determined by the Board in its reasonable discretion, then such Owner shall be required to bear the expense of such service individually (as, for example, by separate metering of utilities) and the common expenses incurred by the other Owners shall thereupon be adjusted accordingly. Any costs or expenses incurred by the Association (including, without limitation, capital improvements and maintenance, upkeep, and repair of Association Property) that are not assessable to an Owner pursuant to Section 5.8 of the Bylaws and not shown on Exhibit C shall be allocated between Retail Expenses and Residential Expenses in a proportion that reasonably and equitably reflects the benefit realized as a result of such cost or expense by the Owners of

the Retail Units and Residential Units, respectively. The allocation described in the preceding sentence shall be determined by the agreement of the director elected by the Owner of the Retail Unit and by a majority of the directors elected by the Owners of Residential Units. In the event such directors are unable to reach agreement on an allocation within 30 days following written notice given to all directors of the cost or expense requiring allocation, the issue shall be submitted to arbitration in accordance with Section 27.5 and the allocation shall be determined conclusively by the arbitrator.

7.2 Commencement of Assessments. Assessments of common expenses shall commence upon closing of the first sale of a Unit provided that Declarant may elect to defer the commencement of assessment of common expenses (other than assessments for reserves pursuant to Section 5.2 of the Bylaws) for a period of 60 days following such initial closing. Assessments for reserves pursuant to Section 14.3 of this Declarations and Section 5.2 of the Bylaws shall commence upon closing of the first sale of a Unit, subject to the right of Declarant to defer the payment of assessments for reserves pursuant to Section 14.3. Declarant shall give not less than 10 days' written notice to all Owners of the commencement of assessments of all common expenses. Until the commencement of assessments for all common expenses, Declarant shall be responsible for payment of all common expenses of the Association (other than assessment for reserves pursuant to Section 5.2 of the Bylaws). Except to the extent provided in the Bylaws, the common expenses of the Property shall be assessed on a monthly basis.

7.3 No Exception. No Owner may claim exemption from liability for contribution toward the common expenses by waiver by the Owner of the use or enjoyment of any of the Common Elements or by abandonment by the Owner of the Owner's Unit. No Owner may claim an offset against an assessment for common expenses for failure of the Board of Directors or Association to perform its obligations.

7.4 Default in Payment of Common Expenses. In the event of default by any Owner in paying to the Association the assessed common expenses (including, but not limited to, reserve assessments or any other special assessments) or any other amounts owing to the Association, such Owner shall be obligated to pay interest on such common expenses from the due date thereof, together with all expenses, including attorneys' fees, incurred by the Association in any proceeding brought to collect such unpaid expenses, or any appeal therefrom. No interest or late charges will be assessed on common expenses paid within 30 days after the due date therefor. Delinquent payments of common expense assessments shall bear interest from the date thereof at a rate equal to four percentage points over the prime or base rate of interest offered by U.S. National Bank of Oregon, or a similar rate of interest at a similar institution if the foregoing rate or bank no longer exists, as in effect on the due date for such payment, but in no event higher than the maximum rate permitted by law. The Board of Directors may also establish and impose charges for late payments of assessments, if the charge imposed is based upon a resolution adopted by the Board of Directors that is delivered to each Unit, mailed to the mailing address of each Unit, or mailed to the mailing addresses designated by the Owners in writing. The Board of Directors shall have the right and duty to recover for the Association such common expenses, together with interest thereon, late charges, if any, and expenses of the proceeding, including attorneys' fees, by an action brought against such Owner

or by foreclosure of the lien which the Board of Directors shall have upon such Owner's Units with respect to all such obligations.

7.5 Foreclosure of Liens for Unpaid Common Expenses. In any action brought by the Association to foreclose a lien on a Unit or Units because of unpaid common expenses, the Owner shall be required to pay a reasonable rental for the use of the Unit or Units during the pendency of the suit, and the plaintiff in such foreclosure suit shall be entitled to the appointment of a receiver to collect such rental. The Board of Directors, acting on behalf of the Association, shall have the power to purchase such Unit or Units at the foreclosure sale and to acquire, hold, lease, mortgage, vote the votes appurtenant to, convey, or otherwise deal with the Unit or Units. An action to recover a money judgment for unpaid common expenses shall be maintainable without foreclosing any lien securing the same.

7.6 First Mortgages; Liability of Subsequent Purchaser. Any lien of the Association against a Unit or Units for common expenses shall be subordinate to tax and assessment liens and any first Mortgage of record, unless there has been compliance with all requirements of Section 100.450(7) of the Act. Where the purchaser or Mortgagee of a Unit or Units obtains title to the Unit or Units as a result of foreclosure of a first Mortgage or by deed in lieu of foreclosure, such purchaser or Mortgagee, his successors and assigns shall not be liable for any of the common expenses chargeable to such Unit or Units which became due prior to the acquisition of title to such Unit or Units by such purchaser or Mortgagee except to the extent provided in Section 100.475(2) of the Act; provided, in the case of a deed in lieu of foreclosure, that the Mortgagee complies with the requirements of Section 100.465(1) of the Act; and provided further, that any sale or transfer of a Unit pursuant to a foreclosure shall not relieve the purchaser or transferee of such Unit from liability for, nor such Unit or Units from the lien of, any common expenses thereafter becoming due. In a voluntary conveyance of a Unit or Units (subject to the restrictions of this Declaration), the grantee shall be jointly and severally liable with the grantor for all unpaid assessments against the grantor of the Unit or Units to the time of grant of conveyance, without prejudice to the grantee's right to recover from the grantor the amounts paid by the grantee therefor. However, upon request of a prospective purchaser, the Board of Directors shall make and deliver a statement of the unpaid assessments against the prospective grantor of the Unit or Units, and the grantee in such case shall not be liable for, nor shall the Unit or Units when conveyed be subject to, a lien filed thereafter for any unpaid assessments against the grantor in excess of the amounts therein set forth.

8. Voting Rights. Subject to the provisions of Section 21 of the Declaration and Section 2.8 of the Bylaws, one (1) vote shall be allocated to each Residential Unit and five (5) votes shall be allocated to Retail Unit R1, three (3) votes to Retail Unit R2 and two (2) votes to R3, all as shown on the Plans. The votes are allocated based on approximate square footage of each of the Retail Units in comparison with the approximate combined square footage of the Residential Units.

9. Use. The Retail Units may be used for commercial purposes only in accordance with the Bylaws. The Residential Units are intended for residential use, as described in Section 7.2 of the Bylaws. The use of the Parking Units shall be limited to the parking of vehicles owned or operated by the Owner, tenant or resident or a Primary Unit, or the employees of such

Owner or tenant (but in no event shall the general public be allowed to use such Parking Units). The Storage Units shall be limited to storing items associated with a Primary Unit.

10. Service of Process. The designated agent to receive service of process in cases described in Section 100.550(1) of the Act is named in the Condominium Information Report which will be filed with the Real Estate Agency in accordance with Section 100.250(1)(a) of the Act.

11. Authority Regarding Easements and Other Property Rights. The Association has the authority, pursuant to Section 100.405(5) and (6) of the Act, to execute, acknowledge, deliver, and record on behalf of the Owners leases, easements, rights of way, licenses, and other similar interests affecting the Common Elements and to consent to vacation of roadways within and adjacent to the Condominium. The granting of any interest pursuant to this Section 11 shall first be approved by Owners holding at least 75 percent of the voting power of the Association, unless otherwise allowed to be approved by the Board under ORS 100.405(6)(a)(B). Consents to vacation of roadways may be approved by the Board.

12. No Restrictions on Alienation. This Declaration and the Bylaws impose no restrictions on the alienation of any Primary Unit. No person or entity may own or shall be entitled to acquire a Parking or Storage Unit unless such person or entity owns or shall simultaneously acquire a Primary Unit, provided that Declarant or its successors and assigns may own unsold Parking and Storage Units even if it has conveyed all Primary Units). Any conveyance, transfer or other disposition ("Transfer") of a Parking or Storage Unit to a person or entity who does not own or who will not acquire a Primary Unit is prohibited. In addition, the following Parking Units may only be sold together: P-1033A and P-1033B; P-1035A and P-1035B; P-1037A and P-1037B; P-1041A and P-1041B; P-1043A and P-1043B; P-1045A and P-1045B; P-1047A and P-1047B; P-1056A and P-1056B; P-1059A and P-1059B; P-1061A and P-1061B; P-1063A and P-1063B; P-1064A and P-1064B; P-1065A and P-1065B; P-1067A and P-1067B; P-1069A and P-1069B; P-1070A and P-1070B; P-1071A and P-1071B; P-2045A and P-2045B; P-2047A and P-2047B; P-2049A and P-2049B; P-2058A and P-2058B; P-2059A and P-2059B; P-2060A and P-2060B; P-2061A and P-2061B; P-2062A and P-2062B; P-2063A and P-2063B; P-2064A and P-2064B; P-2065A and P-2065B; P-2066A and P-2066B; P-2067A and P-2067B; P-2069A and P-2069B; P-2070A and P-2070B; P-2071A and P-2071B; P-2072A and P-2072B; and P-2073A and P-2073B. The following Parking Units and Storage Units may only be sold together: P-1001 and S-B-109; P-1002 and S-B-104; P-1012 and S-B-113; P-1025 and S-B-115; P-1027 and S-B-116; P-1029 and S-B-117; P-1031 and S-B-118; P-1037A, P-1037B and S-B-124; P-1041A, P-1041B and S-B-121; P-1043A, P-1043B and S-B-127; P-1045A, P-1045B and S-B-128; P-1047A, P-1047B and S-B-130; P-1049 and S-B-131; P-1050 and S-B-133; P-1054 and S-B-105; P-1055 and S-B-108; P-1066 and S-B-125; P-1068 and S-B-120; P-1072 and S-B-140; P-1078 and S-B-145; P-2001 and S-B-209; P-2002 and S-B-204; P-2014 and S-B-213; P-2025 and S-B-215; P-2027 and S-B-216; P-2029 and S-B-217; P-2031 and S-B-218; P-2037 and S-B-221; P-2043 and S-B-224; P-2045A, P-2045B and S-B-227; P-2047A, P-2047B and S-B-228; P-2049A, P-2049B and S-B-230; P-2052 and S-B-232; P-2056 and S-B-205; P-2057 and S-B-208; P-2064A, P-2064B and S-B-220; P-2068 and S-B-225; P-2074 and S-B-240; P-2075 and S-B-241; P-2077 and S-B-243; P-2085 and S-B-245; and P-2121 and S-B-250. In the case of a Transfer or attempted Transfer of a Parking or Storage Unit in violation of this

Section 12, in addition to the Association's other rights under this Section 12, the person or entity making or attempting such Transfer shall indemnify and hold harmless the Association and its members from all cost, liability, and damage that the Association or its members may incur (including, without limitation, attorneys' fees and expenses) as a result of such Transfer or attempted Transfer. In the event a person or entity engages or attempts to engage in a Transfer of a Parking or Storage Unit in violation of this Section 12, the Association acting through the Board may, in its sole discretion, fine the offending person or entity in such amounts as it may determine to be appropriate, in addition to any other rights or remedies available to the Association under this Declaration, the Bylaws or applicable law or in equity including, without limitation, the remedies of specific performance and injunction.

13. Maintenance and Repairs; Reserve Fund.

13.1 Maintenance of Common Elements and Parking Units. Except as otherwise provided in this Declaration or the Bylaws, the necessary work to inspect, maintain, repair, or replace the Common Elements, including the exterior surfaces of Storage Units (except the door thereto), and the Parking Units (notwithstanding that such Parking Units are not Common Elements) shall be the responsibility of the Board and shall be carried out as provided in the Bylaws and the Maintenance Plan (defined in Section 5.2 of the Bylaws). Without limitation of the foregoing, the Association shall be responsible for the painting, staining, repair and replacement of the exterior surfaces of all Units (including, without limitation, the repair and replacement of the roof, exterior doors and door frames, windows and window frames); cleaning of the exterior surfaces of all window and door glass; the repair and resurfacing of the ground level courtyard and steel structure located on the YWCA property adjacent to such plaza, pursuant to the terms of that certain Easement recorded as Document No. 2006-047265 in the deed records of Multnomah County, Oregon; and the cutting, pruning, trimming, and watering of all landscaping in the plaza, courtyard and patio on the third floor of the Condominium. The Association is responsible for maintaining warranties in effect for all portions of the Common Elements and Parking Units, to the fullest extent possible. Trash removal from the retail trash disposal area shall be arranged and paid for separately by the Owners and tenants of the Retail Units. If the Mortgagee of any Primary Unit determines that the Board is not providing an adequate inspection, maintenance, repair, and replacement program for the Common Elements and Parking Units, such Mortgagee, at its option, may deliver a notice to the registered agent of the Association, as required pursuant to Section 100.550 of the Act, setting forth the particular defect(s) which it believes exists in the maintenance, repair, and replacement program. If the specified defect(s) are not corrected within 60 days after receipt of such notice, then the Mortgagee, upon written notice to the registered agent that it is exercising its proxy rights thereunder, shall have the right to attend succeeding annual or special meetings of the Association and to cast a vote for each Primary Unit on which it holds a Mortgage on all business coming before such meeting, which proxy rights shall continue until the defect(s) described in the notice are corrected.

13.2 Maintenance of Units. All maintenance of and repairs to any Primary and Storage Unit shall be made by the Owner of such Unit, who shall keep the same in good order, condition, and repair and shall do all redecorating, painting, and staining which at any time may be necessary to maintain the good appearance and condition of his Unit or Units. In addition,

each Owner of a Primary Unit shall be responsible for the maintenance, repair, or replacement of any plumbing, heating or air conditioning fixtures, telephones, water heaters, fans, lighting fixtures and lamps, refrigerators, dishwashers, ranges, or other appliances and accessories that may be in his or her Primary Unit. Each Owner shall maintain the interior doors which provide the means of ingress and egress to and from his or her Primary Unit and Storage Unit (including the repair of any damage thereto), and the windows opening on to his or her Unit (including the repair or replacement of cracked or broken windows, but excluding exterior window washing, which shall be the responsibility of the Association), notwithstanding that such surfaces may be part of the Common Elements. Each Owner of a Storage Unit shall be responsible for the maintenance, repair, and replacement of the exterior doorway or face panel of any Storage Unit and any fixtures thereon, such as knobs, handles, and hinges, the interior surfaces of the Storage Unit, and any lighting fixtures or other fixtures located within, or attached to the interior of, the Storage Unit. Each Owner of a Residential Unit shall keep the patio located adjacent to such Owner's Unit, if any, clean and free of water and debris, notwithstanding that such patio is a Common Element.

13.3 Reserve Fund for Replacing Common Elements. Declarant shall conduct a reserve study as required by the Act and shall establish in the name of the Association a reserve fund for replacement of Common Elements which will normally require replacement in more than three and fewer than 30 years and for the painting of exterior painted surfaces, if any, as provided in Section 5.2 of the Bylaws. **The reserve study assumes that the Board conducts normal, routine maintenance for the items reserved for and that the Board is required to perform pursuant to this Declaration, the Bylaws, the Maintenance Plan and the Act. If the Board fails to perform required maintenance, the reserve fund may be inadequate at the time of the required replacement for one or more elements included in the reserve study.** The reserve fund shall also be governed by Section 5.2 of the Bylaws. Declarant may elect to defer payment of assessments for the reserve fund with respect to a Unit until the time of conveyance of the Unit; provided, however, that Declarant may not defer payment of accrued assessments for the reserve fund beyond the date of the Turnover Meeting, or if the Turnover Meeting is not held, the date the Owners assume administrative control of the Association. The books and records of the Association shall reflect the amount owed by Declarant for all reserve fund assessments.

14. Rights of Access and Use; Reservations by Declarant; Special Declarant Rights.

14.1 In General. Each Owner shall have a perpetual right of reasonable access and use to, through, over, and of each other Unit and the Common Elements as may be required for ingress and egress to and from such Owner's Unit or Units; for the support of such Owner's Unit or Units; and for the installation, operation, repair, maintenance, and replacement of utilities and other systems serving such Owner's Units, including, but not limited to, water, natural gas, air conditioning, cable television, electrical power and wiring, light, or plumbing serving a Primary Unit. The Owner shall use the foregoing rights only as necessary and shall exercise all due care in the exercise of such right and shall be responsible for and indemnify, defend and hold harmless the other Owners from any harm or damage resulting from the exercise of the Owner's rights under this Section 14.1. The specific reference to or reservation of

any rights of access and use in this Declaration does not limit or negate the general easement for Common Elements created by the Act.

14.2 Water Intrusion and Mold Inspection. The Board, acting on behalf of the Association, may authorize entry into any Owner's Unit or Units to conduct a periodic inspection of the Owner's Primary Unit and Storage Unit for water intrusion into the Unit and/or the appearance of mold or mildew within such Unit. Such inspection shall be made by an agent of the Association appointed by the Board of Directors and shall occur at such time as is reasonably convenient to the Owner (or Owner's tenant) and the inspector. Nothing contained within this Section 14.2 is intended to modify the maintenance and repair obligations of any party as provided in the Bylaws and this Declaration.

14.3 Additional Rights Created by Association. The Association, upon prior approval of Owners holding at least 75 percent of the voting power of the Association, may create on behalf of the Owners additional rights of access and use with respect to the General Common Elements. No such right may be granted with respect to a Limited Common Element unless the Owners and Mortgagees of the Primary Units having the right to use such Limited Common Elements consent to the creation of such a right. Nothing in this Section 14.3 shall be construed to enable the Association to revoke, alter, modify, or terminate any easements, rights of way, licenses, or similar interests of record on the date this Declaration is recorded.

14.4 Right of Entry. In addition to the rights granted to the Association elsewhere in this Declaration, the Bylaws, or by the Act, the Board, acting on behalf of the Association, or a managing agent, manager, or any other person authorized by the Board, shall have the right to enter any Owner's Unit or Units in the case of any emergency originating in or threatening such Unit or Units or other Units or Condominium property or requiring repairs in such Unit or Units to protect public safety, whether or not the Owner is present at the time. Each Owner shall also permit such persons to enter the Owner's Unit or Units for the purpose of performing installations, alterations, maintenance, cleaning, or repairs to any Common Element, preventing damage to the Common Elements or another Unit, or inspecting the Unit or Units to verify that the Owner is complying with the restrictions and requirements described in this Declaration, the Bylaws, and/or the Rules and Regulations, provided that requests for entry are made in advance.

14.5 Right of Access and Use for Declarant. Declarant and Declarant's agents, successors, and assigns shall have a right of access and use to, through, over, and of the Common Elements and Units for the purpose of (i) planning, designing, developing, constructing, inspecting, maintaining or repairing structures on the Property, to the extent Declarant is required or authorized to conduct such activities (a) pursuant to this Declaration, the Bylaws, or the Plans, (b) under contracts of sale with purchasers of Units, (c) satisfying any warranty obligation of the Declarant, (d) inspecting the Property for defects or to verify appropriate maintenance is being performed, or (e) under applicable law or regulations, and (ii) carrying out sales activities reasonably necessary for the sale of Units, including, without limitation, the right to use the Units owned by Declarant as model Units and the right to use a Primary Unit owned by Declarant as a sales office, until all Units have been conveyed to persons other than Declarant; provided, however, that Declarant shall restore the portions of the Property which it

accesses or uses pursuant to this Section 14.5 to substantially the same condition that existed prior to such access or use (except to the extent Declarant has constructed improvements contemplated by this Section 14.4). The right of entry and inspection provided in this Section 14.5 shall not in any way obligate the Declarant or Declarant's agents, successors and assigns to make such an inspection, and the decision on whether to inspect Units and the frequency of such inspections, if any, shall be solely within the discretion of the Declarant or its successors and assigns.

14.6 Easement and License Reserved for Declarant. Declarant hereby reserves for itself, its successors, assigns and licensees, a perpetual exclusive easement to use and license the use of the areas labeled on the Plans as "Roof Top Easement Area 1" and "Roof Top Easement Area 2" located on roof above the eighteenth floor, for purposes of installing, operating, and maintaining telecommunications and data transmission services, including, without limitation, the installation, maintenance, and operation of satellite dishes and associated equipment and to retain the revenues therefrom. In addition, Declarant reserves for itself, its successors, assigns and licensees, a perpetual, non-exclusive license to access and use the conduits from the foregoing mechanical space on the roof above the nineteenth floor to the first floor for purposes related to the foregoing easement and to retain the revenues therefrom.

14.7 YWCA Easement. The Association shall perform the obligations set forth in that certain Easement Agreement recorded in the deed records of Multnomah County, Oregon as Document No. 2006-047265, including maintenance of the steel structure located in the easement area.

14.8 Madison Place Easement. A portion of the plaza is subject to that certain Easement Agreement between Declarant, Sockeye Development, LLC and Alder Street Holdings, L.L.C. recorded in the deed records of Multnomah County, Oregon as Document No. 2005-187774 (the "Madison Place Easement"), pursuant to which Declarant granted to Sockeye Development, LLC, Street Holdings, L.L.C. and their respective successors and assigns with respect to the Madison Place property located adjacent to the Condominiums ("Madison Place") certain easements for ingress and egress from SW 11th Avenue to Madison Place for encroachment over the plaza by canopies, by windows, decks and other overhangs of buildings on Madison Place, for use of a portion of the plaza for restaurant service for restaurants located on the Madison Place property, and for the construction and maintenance of private sanitary sewer and storm sewer to serve Madison Place. Except as otherwise provided in the Madison Place Easement, the Association is responsible for operating, maintaining, repairing and replacing the plaza, including the easement area, and shall charge the owner(s) of Madison Place one-half of all such expenses for maintenance of the easement area of the Plaza. Pursuant to the Madison Place Easement, the owner of Madison Place shall be responsible for maintaining the sanitary and storm sewer system serving Madison Place and in the event such maintenance activities interfere with the use of Parking Units, the owner of Madison Place must provide reasonable replacement parking.

14.9 Special Declarant Rights. As more particularly provided in this Section, Declarant, for itself and any successor Declarant, has reserved the following special Declarant rights:

14.9.1 Completion of Improvements. Declarant and its agents, employees, and contractors shall have the right to complete improvements and otherwise perform work that is: (i) authorized by this Declaration; (ii) indicated on the Plans; (iii) authorized by building permits; (iv) provided for under any unit sales agreement between Declarant and a Unit purchaser; (v) necessary to satisfy any express or implied warranty obligation of Declarant; or (vi) otherwise authorized or required by law.

14.9.2 Sales Facilities of Declarant. Declarant and its agents, employees, and contractors shall be permitted to maintain during the period of sale of the Condominium upon such portion of the Property as Declarant may choose, such facilities as in the sole opinion of Declarant may be required, convenient, or incidental to the construction or sale of Units and appurtenant interests, including but not limited to, a business office, storage area, signs, model units, sales office, construction office, and parking areas for all prospective purchasers of Declarant. The provisions of this Section are subject to the provisions of other state law and to local ordinances. The number, size, location, and relocation of such facilities shall be determined from time to time by Declarant in the exercise of its sole discretion; *provided*, that the maintenance and use of such facilities shall not unreasonably interfere with an Owner's use and enjoyment of the Unit and those portions of the Common Elements reasonably necessary to use and enjoy such Unit.

14.9.3 Termination of Declarant Rights. Except as otherwise provided in this Declaration, the special Declarant rights set forth in this Section 14.9 shall continue for so long as (i) Declarant is completing improvements which are within or may be added to this Condominium; (ii) Declarant owns any Units; or (iii) for a period of 10 years after the date of the Turnover Meeting; *provided*, that Declarant may voluntarily terminate any or all of such rights at any time by recording an amendment to this Declaration, which amendment specifies which right is thereby terminated.

14.9.4 Declarant's Easements. Declarant has a non-exclusive easement to, through, and over the Common Elements as may be reasonably necessary for the purpose of discharging Declarant's obligations or exercising special Declarant rights, whether arising under the Act or reserved in this Declaration.

14.9.5 Right to Approve Amendments. Declarant shall have the right to approve amendments proposed by the Owners to this Declaration, the Bylaws, the Plans, and the Rules and Regulations for so long as Declarant owns a Unit or for 10 years from the date this Declaration is recorded, whichever is latest.

14.9.6 Right to Documents. Upon reasonable advance notice to the Board, Declarant shall have the perpetual right to review all inspection and maintenance records of the Association, including, without limitation, changes to the suggested maintenance schedule prepared by Declarant, if any. In addition, upon request from Declarant, the Board shall provide Declarant at Declarant's cost copies of all inspection reports, proposed plans for alterations and copies of all warranty claims. As provided in Section 7.6 of the Bylaws, the Board shall provide Declarant with copies of submissions for alteration requests, advance notice of the Board's

inspections of such alterations, and an opportunity for Declarant, its contractors or agents to accompany the Board's professional advisors on any such inspection.

14.10 Reservation of Unused FAR. Declarant reserves ownership of the air space and air rights above the Property, legally described as all air space lying above an elevation of 341.00 feet, City of Portland Datum, together with the right to transfer to other property the unused and remaining floor area ratio potential ("FAR") of 128,000 square feet for the Property. Promptly upon request of Declarant, its successors and assigns, the Association shall execute any document necessary to transfer the FAR from the Property to property designated by Declarant, its successors and assigns.

15. Partition; Division.

15.1 Partition. The Retail Units may be partitioned into individual discrete premises at any time by the Owner thereof without the consent of Owners of other Units or of the Board of Directors, by the erection of demising walls and partitions or other walls, as determined by the Owners of the Retail Units, in such Owners' sole discretion. The Owners of the Retail Units may change and reconfigure such partitioning at any time in such Owners' sole discretion, subject only to the rights of tenants of a portion of the Retail Units.

15.2 Creating Additional Units from the Retail Units. Pursuant to, and in accordance with the processes set forth in, ORS 100.625, each Owner of each Retail Unit may divide and create each Retail Unit as two or more Units. The maximum number of Units into which each Retail Unit may be divided is three (3). Any Units so created shall be used for commercial purposes, as required prior to such creation. In the event of such division and creation, the interest in the Common Elements reserved for the divided Retail Unit as of the date of this Declaration shall be reallocated by taking the total interest in the Common Elements reserved for the divided Retail Unit and allocating it among the newly created Units on the basis of the ratio of the square footage of each newly created Retail Unit bears to the square footage of all newly created Retail Units, such that there shall be no reallocation of the Retail Unit's interest in the Common Elements. The Limited Common Elements serving the divided Retail Unit shall continue to serve the Units created from such Retail Unit and be used for the same purposes. Retail Expenses assigned to the divided Retail Unit as of the date of this Declaration shall be allocated among all of the newly created Units of the former Retail Unit on the basis of the ratio by which the square footage of each newly created Unit bears to the square footage of all newly created Units, such that there shall be no reallocation of Residential Expenses. Common profits assigned to the Retail Unit then being divided as of the date of recordation of this Declaration shall be reallocated among all of the newly created Retail Units on the basis of the ratio by which the square footage of each newly created Retail Unit bears to the square footage of all newly created Retail Units, such that there shall be no reallocation of common profits assigned to Residential Units. Voting rights shall be allocated by assuming that votes are allocated to all Retail Units based roughly on one vote per 1,000 square feet as of the date of this Declaration

and then assigning votes to the newly created Units pro rata based on the number of square feet of each newly created Unit. For purposes of this Section 15.2, the square footage of the newly created Retail Units shall be measured to the centerpoint of the newly established boundary walls between newly created Retail Units, such that the total square footage of all newly created Retail Units equals the total square footage of the former Retail Unit.

16. Encroachments.

16.1 Each Unit and all Common Elements shall have an easement over all adjoining Units and Common Elements for the purpose of accommodating any present or future encroachment as a result of engineering errors, construction, reconstruction, repairs, settlement, shifting, or other movement of any portion of the Property, or any other similar cause, and any encroachment due to building overhang or projection, including but not limited to any encroachment from the building's HVAC equipment, pipes or utility installations extending down from the ceiling above a Parking Unit installed by Declarant or approved by the Association, provided that any such installation shall not adversely affect the use of the Parking Unit for the parking of motor vehicles that fit in the Parking Unit prior to such installation. There shall be a valid easement for the maintenance of the encroaching Units and Common Elements so long as the encroachment shall exist and, except as otherwise provided in Section 16.2, the rights and obligations of Owners shall not be altered in any way by the encroachment.

16.2 The easement described in Section 16.1 does not relieve an Owner of liability in case of willful misconduct of an Owner or relieve the Declarant or any contractor, subcontractor, or materialman of liability for failure to adhere to the Plans.

16.3 The encroachments described in Section 16.1 shall not be construed to be encumbrances affecting the marketability of title to any Unit.

17. Notices to Mortgagees. The Association shall provide timely written notice of the following matters to any Mortgagee of a Unit, or any insurer or guarantor of a Mortgage on a Unit:

17.1 Any condemnation or casualty loss that affects either a material portion of the Condominium or a Unit in which it holds an interest;

17.2 Any delinquency of 60 days in the payment of common expenses assessed to a Unit in which it holds an interest;

17.3 A lapse, cancellation, or material modification of any insurance policy or fidelity bond maintained by the Association; and

17.4 Any proposed action that requires the consent of a specified percentage of Mortgagees under this Declaration or the Bylaws.

18. Operating Entity. Eliot Tower Condominiums Owners' Association, an Oregon nonprofit corporation, has been organized to administer the operation and management of the

Condominium and to undertake and perform all acts and duties incident thereto in accordance with the terms of its Articles of Incorporation and the Bylaws. A copy of the Bylaws, which have been adopted by the Declarant as required by Section 100.410(1) of the Act, are attached hereto as Exhibit D. The Owner of each Primary Unit shall automatically become a member of the Association upon such Owner's acquisition of an ownership interest in any Primary Unit and the membership of an Owner shall terminate automatically upon such Owner's being divested of all of such Owner's ownership interest in the Primary Units, regardless of the means by which such ownership interest is divested. Each Owner shall be entitled to vote in the manner prescribed in the Articles of Incorporation of the Association and the Bylaws. Until the Turnover Meeting, the members of the Board need not be Owners. No person or entity holding any Mortgage, lien, or other encumbrance on any Unit shall be entitled, by virtue of such Mortgage, lien, or other encumbrance, to membership in the Association or to any of the rights or privileges of such membership, except as specifically described in this Declaration. In the administration of the operation and management of the Condominium, the Association shall have and is hereby granted the authority and power to enforce the provisions of this Declaration, to levy and collect assessments, and to adopt, promulgate, and enforce Rules and Regulations in the manner provided herein and in the Bylaws. Acquisition of an ownership interest in a Primary Unit by an Owner shall constitute appointment of the Association as that Owner's attorney-in-fact in connection with proceedings, negotiations, settlements, and agreements arising from condemnation, destruction, liquidation, or termination of the Condominium, subject to the rights of the Owners described in the Bylaws.

19. Managing Agent. Subject to the rights of the Association to terminate such agreement without penalty or cause upon not less than 30 days' written notice given not later than 60 days after the Turnover Meeting, the Board shall have the authority, on behalf of the Association, to enter into a management agreement with respect to the Condominium prior to the Turnover Meeting for a term not to exceed three (3) years. On behalf of the Association, the Board may, after the Turnover Meeting, employ or contract for a managing agent or manager in accordance with the Bylaws at a compensation to be established by the Board. The Board may delegate to the managing agent or manager such duties and powers as the Board may authorize. In the absence of such appointment, the Board shall act as manager of the Condominium.

20. Taxation of Units. Each Unit, together with the undivided percentage interest in the Common Elements allocated to such Unit, shall be considered a parcel of real property subject to separate assessment and taxation by any taxing authority in a manner comparable to the taxation of other parcels of real property. The Common Elements shall not be considered a separate parcel for purposes of taxation.

21. Administrative Control. Except as otherwise provided in this Declaration or in the Bylaws, Declarant reserves control until the earlier to occur of the date that is three years after the date on which the first Primary Unit is conveyed or the date at which 75 percent of all 661 Units have been conveyed to persons other than the Declarant, during which time:

21.1 Declarant may appoint and remove officers and members of the Board;

21.2 Declarant shall have five (5) votes with respect to each Residential Unit owned by it and twenty-five (25) votes for Retail Unit R1, fifteen (15) votes for Retail Unit R2 and ten (10) votes for Retail Unit R3, notwithstanding the provisions of Section 8; and

21.3 Declarant shall have the right to exercise all powers of the Association, the Board, or the Condominium officers under this Declaration, the Bylaws, and the Act, except that Declarant may not bind the Association to any management agreement, service contract, employment contract, lease of recreational areas or facilities, or contract or lease (other than a ground lease) to which Declarant is a party, which is made prior to the Turnover Meeting unless the Association or the Board is granted therein a right of termination thereof which is exercisable without cause or penalty upon not less than 30 days' written notice given to the other party thereto not later than 60 days after the Turnover Meeting.

22. Casualty.

22.1 Responsibility of Association. The Association shall be responsible for repairing, reconstructing, or rebuilding all damage or destruction of the Common Elements and Parking Units by casualty and, to the extent of the Association's insurance coverage, all such damage or destruction to the other Units. Each Owner shall be responsible for the repairing, reconstructing, or rebuilding of his Primary Units and Storage Units to the extent not covered by the Association's insurance. The Association shall rebuild and restore the damaged or destroyed portions of the Common Elements, Parking Units, and, to the extent of the Association's insurance coverage, of the other Units, so that the Property is rebuilt and restored to substantially the same condition in which it existed prior to such damage or destruction, unless Owners of at least 60 percent of the Primary Units and 75 percent of all first Mortgagees of Primary Units agree that the Property shall not be rebuilt or restored. The Association shall represent the Owners in any proceeding, negotiation, settlement, or agreement relating to the payment of proceeds under any insurance policies held by the Association. Any such proceeds shall be payable to the Association to the extent of its interest therein. If the Property is to be rebuilt and restored and the proceeds of the insurance policies held by the Association are insufficient to fund the full cost of rebuilding and restoration, the difference between the amount of such proceeds and such cost may be charged to all Owners as a common expense. If the required number of Owners and first Mortgagees agree that the Property shall not be rebuilt and restored, the Property shall be considered removed from the provisions of the Act in accordance with Section 100.605 thereof, and any proceeds resulting from such removal shall be distributed in accordance with Section 100.615 of the Act.

22.2 Responsibility of Owner. If, due to the act or neglect of an Owner, or of a member of his family or his household pet or of a guest, servant, invitee, or other authorized occupant or visitor of such Owner, damage shall be caused to the Common Elements or to a Unit owned by others, or maintenance, repairs, or replacements shall be required which would otherwise be a common expense, then such Owner shall pay for such damage and such maintenance, repairs, and replacements as may be determined by the Association, to the extent not covered by the Association's insurance.

23. Condemnation.

23.1 Total Condemnation. In the event of condemnation of the whole of the Condominium, the compensation to be paid to Owners of Units shall be negotiated and finalized, including, if required, by representation in any proceeding, by the Association, subject to ratification of such compensation by the Owners of at least 75 percent of the Primary Units at a special meeting called for that purpose, whether or not proceedings are necessary, and compensation, less expenses involved, if any, in obtaining the compensation shall be paid to the Association and then distributed among the Owners of Units in equitable proportions and payable to any Mortgagee to the extent required to obtain a discharge of Mortgage. Notwithstanding the award for the condemnation of the whole Condominium, the rights of each Owner of a Unit shall be separate to negotiate and finalize his personal compensation for improvements made to the Unit or Units, cost of moving, and other similar items personal to each Owner.

23.2 Partial Condemnation. In the event of a partial condemnation of the Condominium which includes some Units and/or Limited Common Elements, each Owner whose Unit or Units or associated Limited Common Elements are condemned shall deal with the condemning authority with regard to compensation therefor, and the compensation for such Unit or Units or Limited Common Elements shall be paid to such Owner (or the Mortgagee of that Owner's Unit). The Association shall negotiate compensation relating to any General Common Elements (except as provided above). The cost, if any, of restoring the balance of the Condominium so that it may be used shall be determined by the Association and the Association shall negotiate with the condemning authority with regard to compensation for this expenditure and shall, unless the Condominium is terminated within 30 days after the receipt of such compensation in accordance with the Act, reconstruct the Condominium, using the funds received for such reconstruction. Any moneys received by the Association for any such reconstruction shall be held in trust by the Association for the purpose of such reconstruction.

24. Fidelity Bond. The Board of Directors shall require that any person or entity, including, but not limited to, employees of any professional manager, who handles or is responsible for Association funds, whether or not such person or entity receives compensation for services, shall furnish a fidelity bond as the Board of Directors deems adequate under this Section 24. Such bonds shall name the Association as the obligee and shall cover the maximum funds that may be in the custody of the Association or any manager at any time while such bonds are in force but, in any event, not less than the sum of three months of common expense assessments on all Units. Any such bond shall include a provision requiring not less than ten days' written notice to the Association and any Mortgagee of a Unit requesting a copy thereof before cancellation or substantial modification of the bond for any reason. The premiums on such bonds shall be paid by the Association.

25. Amendment.

25.1 Approval by Owners. Except as may otherwise be provided in this Declaration or by the Act, this Declaration may be amended if such amendment is approved by Owners holding at least 75 percent of the voting power of the Association and the consent of

Declarant or its successors for 10 years after this Declaration is recorded in the deed records of Multnomah County, Oregon; provided that any amendment to the provisions of this Declaration that relates solely to, or that imposes additional burdens upon or takes away rights particular only to, the Residential Units or the Retail Units shall, in addition to the voting requirements stated previously in this sentence, require 75 percent of the voting power of the Residential Units, if the Residential Units are so affected, and 75 percent of the votes of the Retail Units, if the Retail Units are so affected. The unanimous consent of all Owners of Primary Units shall be required for amendments of Sections 14.2 and 17 of this Declaration. Section 9 of this Declaration may not be amended in a manner that limits or restricts the use for retail or office purposes of the Retail Units, shown on the Plan, without the written consent of the Owners of such Retail Units.

Except as otherwise provided in the Act, no amendment may change the allocation of undivided interest in the Common Elements, method for determining liability for common expenses, the method of determining the right to common profits, or the method of determining the voting rights of or with respect to any Unit unless such amendment has been approved by the Owners of the affected Units. Voting on any amendment to this Declaration shall be without regard to Declarant's enhanced voting power under Section 20.2, except for an amendment to approve a plat amendment, or to correct any provision of or exhibit to this Declaration, whether such correction is required due to a surveyor's error, factual error, miscalculation, omission or to comply with the requirements of any applicable statute, ordinance, regulation or guideline of the Federal Housing Administration, the Veterans Administration, the Farmers Home Administration of the United States, the Federal National Mortgage Association, the Government National Mortgage Association, the Federal Home Loan Mortgage Corporation, any department, bureau, board, commission or agency of the United States or the State of Oregon, or any corporation wholly owned, directly or indirectly, by the United States or the State of Oregon that insures, guarantees or provides financing for condominiums or to comply with the Act. For as long as Declarant remains the Owner of one or more Primary Units, the Bylaws, the Rules and Regulations, and this Declaration may not be modified, added to, amended, or repealed so as to eliminate, change, or impair any rights, privileges, easements, licenses, or exemptions granted therein or herein to Declarant or its designee, or otherwise so as adversely to affect Declarant or such designee, without Declarant's or such designee's prior written consent in each instance.

25.2 Approval by Mortgagees. Amendment of any of the following provisions of this Declaration shall require the prior written approval of at least 51 percent of those holders of first Mortgages on Units (based upon one vote for each first Mortgage held):

25.2.1 Section 4.3, which addresses Unit boundaries;

25.2.2 Section 5, which addresses the allocation of interests in the Common Elements and the description of the General Common Elements;

25.2.3 Section 6, which addresses the Limited Common Elements;

25.2.4 Section 7, which addresses the allocation of common profits and expenses and related matters;

25.2.5 Section 8, which addresses voting rights;

- 25.2.6 Section 12, which addresses restrictions on alienation of Units;
- 25.2.7 Section 13, which addresses maintenance and repairs;
- 25.2.8 Sections 14.1, 14.2, 14.3 and 14.4, which address use of and access to the Common Elements;
- 25.2.9 Section 17, which addresses notices to Mortgagees;
- 25.2.10 Section 22, which addresses casualty loss;
- 25.2.11 Section 23, which addresses condemnation;
- 25.2.12 Section 24, which addresses fidelity bonds;
- 25.2.13 This Section 25;
- 25.2.14 Section 26, which addresses termination of the Condominium; and
- 25.2.15 Any other provision of this Declaration which expressly benefits Mortgagees of a Unit or insurers or guarantors of a Mortgage on a Unit.

In addition, except as otherwise provided in the Act, no amendment to this Declaration may change the allocation of undivided interest in the Common Elements, method for determining liability for common expenses, right to common profits, or voting rights of or with respect to any Unit unless such amendment has been approved by the holders of any Mortgages on the affected Units. Any approval of a Mortgagee required under this Section 25 may be presumed by the Association if such Mortgagee fails to submit a response to a written proposal for an amendment to this Declaration within 60 days after it receives notice of such proposal by certified or registered mail, return receipt requested.

25.3 Approval by Governmental Authorities. The Association shall use reasonable efforts to obtain the approval of an amendment to this Declaration by a governmental authority engaged in the guaranty of, or the issuance of insurance with respect to, Mortgages, if required by such authority.

25.4 Recordation. Amendments to this Declaration shall be effective upon recordation of the Declaration as amended, or of the amendment thereto, certified by the chairman and secretary of the Association and approved by the county assessor and the Oregon Real Estate Commissioner, if required by law, in the deed records of Multnomah County, Oregon.

26. Termination. Termination of the Condominium shall be effected in accordance with Section 100.600 and any other applicable provision of the Act, but in no event shall be consummated, other than in connection with the substantial destruction or condemnation of the Property, without the prior written consent of at least 51 percent of those holders of first Mortgages on Units (based upon one vote for each first Mortgage held). Any approval of a

Mortgagee required under this Section 26 may be presumed by the Association if such Mortgagee fails to submit a response to a written proposal for an amendment to this Declaration within 60 days after it receives notice of such proposal by certified or registered mail, return receipt requested. The common profits and expenses of the Property following termination of the Condominium shall be allocated in accordance with the Act.

27. Dispute Resolution.

27.1 Required Procedure. Except as provided in Section 27 below, to the fullest extent allowed by law, if a dispute arises, all claims, controversies, or disputes, whether they are statutory, contractual, tort claims, and/or counterclaims between or among Declarant, Declarant's successors and assigns, the Association, and/or Owner(s) (collectively, the "Parties" and individually, a "Party") which arise out of or are related to the Condominium, the Act, this Declaration, the Bylaws, the Articles of Incorporation of the Association, or the Rules and Regulations, or which relate to the interpretation or breach of the Act, this Declaration or the Bylaws, the Articles of Incorporation of the Association, or the Rules and Regulations (collectively referred to as "Claims") shall be resolved in accordance with the procedures specified herein. Except as otherwise required by the Act, the following matters are excluded from this dispute resolution clause and do not constitute Claims: (i) judicial or non-judicial foreclosure or any other action or proceeding to enforce assessments, fines, interest or a trust deed, mortgage, Association lien, or land sale contract; (ii) a forcible entry and detainer action; or (iii) actions by the Association pursuant to Section 5.6 of the Bylaws prior to summary abatement and removal of a structure or other condition that violates this Declaration, the Bylaws or any Rules and Regulations; (iv) actions for the appointment of a receiver pursuant to Section 5.9 of the Bylaws; (v) provisional remedies such as injunctions or the filing of a lis pendens, or (vi) the filing or enforcement of a mechanic's lien. The filing of a notice of pending action (lis pendens) or the application to any court having jurisdiction thereof for the issuance of any provisional process remedy described in Rules 79 through 85 of the Oregon Rules of Civil Procedure (or corresponding federal statutory remedies), including a restraining order, attachment, or appointment of receiver, shall not constitute a waiver of the right to mediate or arbitrate under this Section, nor shall it constitute a breach of the duty to mediate or arbitrate. The proceeds resulting from the exercise of any such remedy shall be held by the Party obtaining such proceeds for disposition as may be determined by an agreement of the Parties pursuant to a mediation or by the arbitration award.

27.2 Negotiated Resolution. The Parties will seek a fair and prompt negotiated resolution of Claims and shall meet at least once to discuss and to seek to resolve such claims, but if this is not successful, all disputes shall be resolved in small claims court, by mediation or by binding arbitration as set forth in Sections 27.3, 27.4 and 27.5 below, as applicable.

27.3 Mediation. Prior to mediation of any Claim, the Parties shall have endeavored to resolve disputes through the process set forth in Section 27.2 above. All Claims that are not resolved by such process shall be subject to mediation as a condition precedent to arbitration. The request for mediation may be made concurrently with the filing of a demand for arbitration as set forth in Section 27.5 below, but, in such event, mediation shall proceed in advance of arbitration, which shall be stayed pending mediation for a period of 60 days from the date of

filing, unless stayed for a longer period by agreement of the Parties. All mediation shall be in accordance with the rules of procedure of any dispute resolution program available in Multnomah County, Oregon that is in substantial compliance with the standards and guidelines adopted under ORS 36.175, as it may be amended.

27.4 Small Claims. All Claims that have not been resolved by mediation and which are within the jurisdiction of the Small Claims Department of the Circuit Court of the State of Oregon shall be brought and determined there, and all Parties waive their right to a jury trial with respect to such claims.

27.5 Arbitration. Prior to arbitration of any Claim, the Parties shall have endeavored to resolve disputes through the processes set forth in Section 27.2, 27.3 and 27.4 above, as applicable. All Claims that have not been resolved by such processes shall be resolved by binding arbitration. Such arbitration shall be conducted by and pursuant to the then effective arbitration rules of the American Arbitration Association, or another reputable arbitration service selected by Declarant. If Declarant is not a Party to such dispute, the arbitration service shall be selected by the Association. Any judgment upon the award rendered pursuant to such arbitration may be entered in any court having jurisdiction thereof.

27.6 Claims Procedure. An Owner or the Association may not commence arbitration against Declarant or any contractor, subcontractor or supplier for construction defects unless the Owner or Association, as applicable, has given written notice of the claim and permitted them to view, inspect and respond to the claimed defect, as required by law.

OREGON LAW CONTAINS IMPORTANT REQUIREMENTS YOU MUST FOLLOW BEFORE YOU MAY COMMENCE ARBITRATION OR A COURT ACTION AGAINST ANY CONTRACTOR, SUBCONTRACTOR OR SUPPLIER FOR CONSTRUCTION DEFECTS. BEFORE YOU COMMENCE ARBITRATION OR A COURT ACTION YOU MUST DELIVER A WRITTEN NOTICE OF ANY CONDITIONS YOU ALLEGE ARE DEFECTIVE TO THE CONTRACTOR, SUBCONTRACTOR OR SUPPLIER YOU BELIEVE IS RESPONSIBLE FOR THE ALLEGED DEFECT AND PROVIDE THE CONTRACTOR, SUBCONTRACTOR OR SUPPLIER THE OPPORTUNITY TO MAKE AN OFFER TO REPAIR OR PAY FOR THE DEFECTS. YOU ARE NOT OBLIGATED TO ACCEPT ANY OFFER MADE BY THE CONTRACTOR, SUBCONTRACTOR OR SUPPLIER. THERE ARE STRICT DEADLINES AND PROCEDURES UNDER STATE LAW. FAILURE TO MEET THOSE DEADLINES OR FOLLOW THOSE PROCEDURES WILL AFFECT YOUR ABILITY TO COMMENCE ARBITRATION OR A COURT ACTION.

27.7 Limitations on Actions. Notwithstanding any other provision of the Declaration or these Bylaws, the Association shall not expend or commit to expend in excess of

\$2,500 for attorneys' fees and costs unless first approved by at least 75 percent of the outstanding votes of the Owners. The foregoing limitation shall not apply to actions for delinquent assessments or other charges under the Declaration or these Bylaws, for actions initiated by the Association during Declarant's period of administrative control pursuant to Section 21 of this Declaration; for actions challenging ad valorem taxation or condemnation proceedings; initiated against any contractor or vendor hired by the Association or supplier of goods and services to the Association; to defend claims filed against the Association or to assert counterclaims in proceedings instituted against it; actions to appoint a receiver pursuant to Section 5.9 of the Bylaws; actions to summarily abate and remove a structure or condition that violates this Declaration or the Bylaws; or for the defense of the Association of an action or proceeding brought against the Association (except for non-mandatory counterclaims).

27.8 Confidentiality. The Parties shall keep all discussions of disputes, all settlements and arbitration awards and decisions confidential and shall not disclose any such information, whether directly or indirectly, to any third parties unless compelled to do so by an order of a court of competent jurisdiction. The Parties agree in the event a Party breaches its confidentiality obligation that the other Party or Parties to the dispute shall be entitled to seek and obtain any and all equitable remedies, including injunctive relief and specific performance and each Party hereby waives any claim or defense that the other Party has an adequate remedy at law for any such breach and the Parties agree that the aggrieved Party shall not be required to post any bond or other security in connection with any such equitable relief.

27.9 No Attorneys' Fees. Except as specifically provided for in this Declaration or the Bylaws, no Party in the arbitration, mediation or other proceeding shall be entitled to recover costs or attorneys' fees in connection therewith.

28. Waiver, Time Limitation.

28.1 **RELEASE AND WAIVER OF ALL OTHER PAST, PRESENT, AND FUTURE CLAIMS REGARDING CONDITION OF PROPERTY**. EXCEPT FOR ANY EXPRESS WARRANTY CLAIMS PURSUANT TO SECTION 8 OF THE UNIT SALES AGREEMENT BETWEEN DECLARANT AND A PURCHASER OF A UNIT, TO THE FULLEST EXTENT ALLOWED BY LAW, EACH PURCHASER OF A UNIT, THE ASSOCIATION AND ALL SUCCESSOR OWNERS AND OCCUPANTS, RELEASE AND WAIVE ANY CLAIM WHENEVER ARISING AGAINST DECLARANT OR ITS AGENTS, BROKERS, SUCCESSORS, EMPLOYEES, AFFILIATES, CONTRACTORS, REPRESENTATIVES, OFFICERS, DIRECTORS AND MEMBERS OR AGAINST THE ASSOCIATION OR ANY BOARD MEMBER THEREOF (COLLECTIVELY, THE "DECLARANT PARTIES"), RELATING TO OR ARISING FROM THE CONDITION OF THE CONDOMINIUM PROPERTY AT ANY TIME. THE WAIVER IS ABSOLUTE AND UNCONDITIONAL, AND THIS RELEASE AND WAIVER APPLIES WHETHER OR NOT THE PURCHASER HAD KNOWLEDGE OF ANY POTENTIAL CAUSE OF ACTION FOR SUCH CLAIMS. THE WAIVER APPLIES TO CLAIMS UNDER ANY LEGAL THEORY OTHER THAN THE WARRANTY GIVEN BY DECLARANT IN A UNIT SALES AGREEMENT, INCLUDING BUT NOT LIMITED TO NEGLIGENCE, NEGLIGENCE PER SE, NEGLIGENT OR INTENTIONAL MISREPRESENTATION, DEFECTIVE

CONSTRUCTION, BREACH OF CONTRACT, UNLAWFUL TRADE PRACTICE, BREACH OF FIDUCIARY DUTY, STRICT LIABILITY, NUISANCE, TRESPASS OR ANY OTHER THEORY, WHETHER ARISING FROM STATUTE, CONTRACT, TORT OR OTHERWISE. THIS WAIVER INCLUDES, WITHOUT LIMITATION, CLAIMS RELATING TO CONSTRUCTION DEFECTS, WATER INTRUSION, MOLD, MILDEW, FUNGUS AND/OR ODORS IN THE UNIT OR COMMON ELEMENTS; PRODUCTS OR CONDITIONS IN THE UNIT OR COMMON ELEMENTS, INCLUDING FOR EXAMPLE CARBON MONOXIDE, RADON OR CARPET GLUE; NOISE OR SOUND TRANSMISSION; LOSS OF USE; EMOTIONAL DISTRESS; INCIDENTAL OR CONSEQUENTIAL DAMAGES; ATTORNEY FEES AND COSTS; OR RELOCATION EXPENSES (TEMPORARY OR OTHERWISE). IT IS ACKNOWLEDGED THAT DECLARANT WOULD HAVE REQUIRED A SIGNIFICANTLY HIGHER PURCHASE PRICE FOR THE UNITS IF THE PURCHASER REFUSED TO PROVIDE THIS RELEASE AND WAIVER. THIS SECTION 28.1 SERVES AS NOTICE OF RECORD THAT THE RELEASE AND WAIVER SHALL BE BINDING UPON SUCH PURCHASERS, ALL SUCCESSOR OWNERS OR OCCUPANTS OF THE UNIT, THE ASSOCIATION, AND THEIR RESPECTIVE EMPLOYEES, CONTRACTORS, PROPERTY MANAGERS, BROKERS, HEIRS, SUCCESSORS, ASSIGNS, GUESTS AND INVITEES. CLAIMS OF THE ASSOCIATION ARE DERIVATIVE OF CLAIMS OF UNIT OWNERS AND THE ASSOCIATION SHALL BE BOUND BY THE WAIVER. THE WAIVER ACTS AS A COMPLETE BAR AND DEFENSE AGAINST ANY RELEASED OR WAIVED CLAIM.

28.2 TIME LIMITATION ON ACTIONS. THE FOREGOING RELEASES AND WAIVERS OF CLAIMS ARE INTENDED TO BE COMPREHENSIVE AND FINAL. TO THE EXTENT IT IS DETERMINED THAT ANY CLAIMS AGAINST ANY DECLARANT PARTY, UNDER ANY LEGAL THEORY, SURVIVE THE FOREGOING RELEASE AND WAIVER FOR ANY REASON, SUCH CLAIM MUST BE BROUGHT ON OR BEFORE THE EARLIER OF (A) THE EXPIRATION OF THE APPLICABLE STATUTE OF LIMITATIONS, OR (B) WITHIN 60 DAYS AFTER THE DATE PURCHASER, PURCHASER'S SUCCESSORS OR THE ASSOCIATION KNEW OR REASONABLY SHOULD HAVE KNOWN OF FACTS SUFFICIENT TO PUT IT ON NOTICE OF THE CLAIM, OR (C) WITH RESPECT TO THE UNIT AND RELATED LIMITED COMMON ELEMENTS, BY NO LATER THAN THE FIRST ANNIVERSARY OF THE CLOSING DATE OF THE SALE OF THE APPLICABLE UNIT FROM DECLARANT TO THE INITIAL PURCHASER OR, (D) WITH RESPECT TO THE GENERAL COMMON ELEMENTS, ON THE LATER TO OCCUR OF (I) THE FIRST ANNIVERSARY OF THE DATE OF THE FIRST CONVEYANCE OF A UNIT IN THE CONDOMINIUM TO A UNIT OWNER OTHER THAN DECLARANT OR (II) THE FIRST ANNIVERSARY OF THE DATE OF COMPLETION OF CONSTRUCTION OR RENOVATION OF THE GENERAL COMMON ELEMENT IN QUESTION. ANY AND ALL SUCH CLAIMS NOT BROUGHT WITHIN THIS TIME PERIOD WILL BE DEEMED TIME BARRED, REGARDLESS OF WHEN PURCHASER, PURCHASER'S SUCCESSORS OR THE ASSOCIATION ACTUALLY DISCOVERED THE ALLEGED BASIS FOR THE CLAIM. FOR PURPOSES OF THIS SECTION 28.2, A CLAIM IS "BROUGHT" WHEN ARBITRATION IS FORMALLY INITIATED OR A COMPLAINT IS FILED IN THE APPROPRIATE COURT AND SERVED PROMPTLY ON DECLARANT.

29. Severability. Each provision of this Declaration and the Bylaws shall be deemed independent and severable, and the validity or partial invalidity of any provision shall not affect the validity or enforceability of the remaining part of that or any other provision of this Declaration or the Bylaws.

12th IN WITNESS WHEREOF, Declarant has caused this Declaration to be executed this day of April, 2006.

ELIOT TOWER LLC, an Oregon limited liability company
By: Eliot Equity Investors, LLC, an Oregon limited liability company, Its: Manager
By: Carroll Eliot Development Services, LLC, an Oregon limited liability company, its Manager

By: [Signature]
Its: Authorized Agent

STATE OF OREGON)
County of Multnomah)

) ss. Eliot Equity Investors, LLC, Manager of)

This instrument was acknowledged before me on April 12, 2006, by John Carroll, Authorized Agent of Carroll Eliot Development Services, LLC, Manager of Eliot Tower LLC, an Oregon limited liability company, on behalf of and as the act and deed of said limited liability company.



[Signature]
Notary Public for Oregon
My Commission Expires: 5-24-06

The foregoing Declaration is approved pursuant to ORS 100.110 this 3rd day of May, 2006, and in accordance with ORS 100.110(7), this approval shall automatically expire if this Declaration is not recorded within two (2) years from this date.

SCOTT W. TAYLOR
Real Estate Commissioner

By: [Signature]
Laurie Skillman

APPROVED MAY 5, 2006

By Dan Bunn
County Assessor, MULTNOMAH COUNTY
OREGON

By J. Bunn MAY 5, 2006
County Tax Collector, MULTNOMAH COUNTY
OREGON

EXHIBIT A

Property Description

"ELIOT TOWER CONDOMINIUMS", BEING LOTS 1-8, BLOCK 246, "CITY OF PORTLAND", A DULY RECORDED SUBDIVISION, MULTNOMAH COUNTY PLAT RECORDS, TOGETHER WITH THE SOUTHERLY 30 FEET OF VACATED SW MADISON STREET, SITUATED IN THE NE 1/4 OF SECTION 4, T. 1 S., R. 1 E., W.M., CITY OF PORTLAND, MULTNOMAH COUNTY, OREGON, AND BEING MORE PARTICULARLY DESCRIBED AS FOLLOWS:

BEGINNING AT THE INITIAL POINT, BEING THE SOUTHWEST CORNER OF SAID BLOCK 246 AND REFERENCED BY A FOUND BRASS SCREW WITH 3/4" BRASS WASHER STAMPED "PLS 2613" BEARING SOUTH 67°19'00" WEST 7.07 FEET FROM THE INITIAL POINT WHICH WAS DESTROYED BY CONSTRUCTION AND REPLACED WITH A SET 5/8" x 30" IRON ROD WITH YELLOW PLASTIC CAP MARKED "WESTLAKE CONSULTANTS"; THENCE, ALONG THE EASTERLY RIGHT-OF-WAY LINE OF SW 11TH AVENUE (40.00 FEET FROM THE CENTERLINE THEREOF, WHEN MEASURED AT RIGHT ANGLES), NORTH 22°19'00" EAST A DISTANCE OF 230.00 FEET TO THE CENTERLINE OF VACATED S.W. MADISON STREET; THENCE, ALONG SAID CENTERLINE, SOUTH 67°41'00" EAST A DISTANCE OF 200.00 FEET TO THE WESTERLY RIGHT-OF-WAY LINE OF SW 10TH AVENUE (40.00 FEET FROM THE CENTERLINE THEREOF, WHEN MEASURED AT RIGHT ANGLES); THENCE, ALONG SAID WESTERLY RIGHT-OF-WAY LINE, SOUTH 22°19'00" WEST A DISTANCE OF 230.00 FEET TO THE NORTHERLY RIGHT-OF-WAY LINE OF SW JEFFERSON STREET (30.00 FEET FROM THE CENTERLINE THEREOF, WHEN MEASURED AT RIGHT ANGLES); THENCE, ALONG SAID NORTHERLY RIGHT-OF-WAY LINE, NORTH 67°41'00" WEST A DISTANCE OF 200.00 FEET TO THE INITIAL POINT.

EXCEPTING THEREFROM ALL AIR SPACE LYING ABOVE AN ELEVATION OF 341.00 FEET, CITY OF PORTLAND DATUM.

CONTAINING: 46,000 SQUARE FEET, MORE OR LESS.

TOGETHER WITH THOSE PORTIONS OF THE BUILDING WHICH EXTEND INTO THE PUBLIC RIGHTS-OF-WAY PURSUANT TO AN APPURTENANT RIGHT TO USE ADJOINING RIGHT-OF-WAY PER CITY OF PORTLAND PERMIT NUMBER 03-174704-000-00-CO.

EXHIBIT B
Area of Units and Allocation of Interest in Common Elements

<u>Unit No.</u>	<u>Area (sq. ft.)</u>	<u>Allocation of Interest</u>
<i>Retail</i>		
R-1	3,108	0.99%
R-2	4,790	1.52%
R-3	1,320	0.42%
<i>Residential</i>		
101	953	0.30%
102	942	0.30%
103	1,498	0.48%
104	1,512	0.48%
105	1,512	0.48%
106	1,535	0.49%
107	763	0.24%
108	773	0.25%
109	773	0.25%
110	791	0.25%
201	1,523	0.48%
202	832	0.26%
203	842	0.27%
204	840	0.27%
205	748	0.24%
206	1,525	0.48%
207	1,138	0.36%
208	1,145	0.36%
209	922	0.29%
210	775	0.25%
211	742	0.24%
212	734	0.23%
213	726	0.23%
214	690	0.22%
215	685	0.22%
216	685	0.22%
217	724	0.23%
218	936	0.30%
219	1,025	0.33%
220	891	0.28%
302	1,822	0.58%
303	798	0.25%
304	854	0.27%
305	1,854	0.59%
306	1,134	0.36%
307	916	0.29%

EXHIBIT B
Area of Units and Allocation of Interest in Common Elements

<u>Unit No.</u>	<u>Area (sq. ft.)</u>	<u>Allocation of Interest</u>
308	827	0.26%
309	831	0.26%
310	878	0.28%
311	847	0.27%
312	817	0.26%
313	1,302	0.41%
314	508	0.16%
315	771	0.25%
316	739	0.23%
317	730	0.23%
318	722	0.23%
401	2,038	0.65%
402	1,378	0.44%
403	853	0.27%
404	907	0.29%
405	2,135	0.68%
406	1,568	0.50%
407	1,396	0.44%
408	872	0.28%
409	872	0.28%
410	916	0.29%
411	893	0.28%
412	857	0.27%
413	1,487	0.47%
414	559	0.18%
501	2,056	0.65%
502	1,379	0.44%
503	853	0.27%
504	908	0.29%
505	2,144	0.68%
506	1,568	0.50%
507	1,346	0.43%
508	872	0.28%
509	872	0.28%
510	916	0.29%
511	893	0.28%
512	857	0.27%
513	1,487	0.47%
514	559	0.18%
601	2,050	0.65%
602	1,378	0.44%
603	859	0.27%

EXHIBIT B
Area of Units and Allocation of Interest in Common Elements

<u>Unit No.</u>	<u>Area (sq. ft.)</u>	<u>Allocation of Interest</u>
604	915	0.29%
605	2,137	0.68%
606	1,568	0.50%
607	1,346	0.43%
608	872	0.28%
609	872	0.28%
610	916	0.29%
611	893	0.28%
612	857	0.27%
613	1,487	0.47%
614	559	0.18%
701	2,056	0.65%
702	1,379	0.44%
703	853	0.27%
704	908	0.29%
705	2,144	0.68%
706	1,568	0.50%
707	1,346	0.43%
708	872	0.28%
709	872	0.28%
710	916	0.29%
711	893	0.28%
712	857	0.27%
713	1,487	0.47%
714	559	0.18%
801	2,050	0.65%
802	1,378	0.44%
803	859	0.27%
804	915	0.29%
805	2,137	0.68%
806	1,568	0.50%
807	1,346	0.43%
808	868	0.28%
809	865	0.27%
810	916	0.29%
811	893	0.28%
812	857	0.27%
813	1,487	0.47%
814	559	0.18%
901	2,056	0.65%
902	1,379	0.44%
903	853	0.27%

EXHIBIT B
Area of Units and Allocation of Interest in Common Elements

<u>Unit No.</u>	<u>Area (sq. ft.)</u>	<u>Allocation of Interest</u>
904	908	0.29%
905	2,144	0.68%
906	1,568	0.50%
907	1,346	0.43%
908	868	0.28%
909	865	0.27%
910	916	0.29%
911	891	0.28%
912	857	0.27%
913	1,487	0.47%
914	559	0.18%
1001	2,050	0.65%
1002	1,378	0.44%
1003	859	0.27%
1004	915	0.29%
1005	2,137	0.68%
1006	1,568	0.50%
1007	1,346	0.43%
1008	868	0.28%
1009	865	0.27%
1010	916	0.29%
1011	891	0.28%
1012	857	0.27%
1013	1,487	0.47%
1014	559	0.18%
1101	2,067	0.66%
1102	1,381	0.44%
1103	848	0.27%
1104	903	0.29%
1105	2,149	0.68%
1106	1,570	0.50%
1107	1,351	0.43%
1108	870	0.28%
1109	865	0.27%
1110	1,360	0.43%
1112	1,319	0.42%
1113	1,500	0.48%
1114	568	0.18%
1201	2,060	0.65%
1202	1,380	0.44%
1203	854	0.27%
1204	910	0.29%

EXHIBIT B
Area of Units and Allocation of Interest in Common Elements

<u>Unit No.</u>	<u>Area (sq. ft.)</u>	<u>Allocation of Interest</u>
1205	2,144	0.68%
1206	1,570	0.50%
1207	1,351	0.43%
1208	870	0.28%
1209	866	0.28%
1210	1,360	0.43%
1212	1,319	0.42%
1213	1,500	0.48%
1214	568	0.18%
1301	2,067	0.66%
1302	1,381	0.44%
1303	854	0.27%
1304	910	0.29%
1305	2,151	0.68%
1306	1,570	0.50%
1307	1,355	0.43%
1308	870	0.28%
1309	865	0.27%
1310	1,372	0.44%
1312	1,338	0.42%
1313	1,500	0.48%
1314	568	0.18%
1401	2,060	0.65%
1402	1,380	0.44%
1403	860	0.27%
1404	916	0.29%
1405	2,144	0.68%
1406	1,570	0.50%
1407	1,355	0.43%
1408	870	0.28%
1409	865	0.27%
1410	1,372	0.44%
1412	1,338	0.42%
1413	1,500	0.48%
1414	568	0.18%
1501	2,072	0.66%
1502	1,381	0.44%
1503	863	0.27%
1504	830	0.26%
1505	1,731	0.55%
1506	1,570	0.50%
1507	1,355	0.43%

EXHIBIT B
Area of Units and Allocation of Interest in Common Elements

<u>Unit No.</u>	<u>Area (sq. ft.)</u>	<u>Allocation of Interest</u>
1508	865	0.27%
1509	865	0.27%
1510	1,364	0.43%
1512	1,333	0.42%
1513	1,503	0.48%
1514	568	0.18%
1601	4,377	1.39%
1603	2,595	0.83%
1604	2,957	0.94%
1605	1,519	0.48%
1606	1,588	0.49%
1607	2,351	0.75%
1701	2,620	0.83%
1702	1,722	0.55%
1703	2,593	0.82%
1704	2,964	0.94%
1705	1,526	0.49%
1706	1,594	0.51%
1707	2,356	0.75%
1801	4,387	1.39%
1803	2,594	0.82%
1804	2,958	0.94%
1805	1,528	0.49%
1806	1,590	0.51%
1807	2,332	0.74%
 <i>Parking</i>		
P-1001	141	0.01%
P-1002	141	0.01%
P-1003	165	0.01%
P-1004	165	0.01%
P-1005	159	0.01%
P-1006	165	0.01%
P-1007	165	0.01%
P-1008	150	0.01%
P-1009	133	0.01%
P-1010	133	0.01%
P-1011	139	0.01%
P-1012	171	0.01%
P-1013	145	0.01%
P-1014	142	0.01%
P-1015	158	0.01%

EXHIBIT B
Area of Units and Allocation of Interest in Common Elements

<u>Unit No.</u>	<u>Area (sq. ft.)</u>	<u>Allocation of Interest</u>
P-1016	158	0.01%
P-1017	216	0.01%
P-1018	153	0.01%
P-1019	193	0.01%
P-1020	153	0.01%
P-1021	153	0.01%
P-1022	153	0.01%
P-1023	193	0.01%
P-1024	153	0.01%
P-1025	145	0.01%
P-1026	153	0.01%
P-1027	145	0.01%
P-1028	153	0.01%
P-1029	150	0.01%
P-1030	153	0.01%
P-1031	150	0.01%
P-1032	153	0.01%
P-1033A	152	0.01%
P-1033B	138	0.01%
P-1034	153	0.01%
P-1035A	152	0.01%
P-1035B	138	0.01%
P-1036	153	0.01%
P-1037A	159	0.01%
P-1037B	145	0.01%
P-1038	153	0.01%
P-1039	153	0.01%
P-1040	153	0.01%
P-1041A	157	0.01%
P-1041B	144	0.01%
P-1042	153	0.01%
P-1043A	150	0.01%
P-1043B	138	0.01%
P-1044	153	0.01%
P-1045A	150	0.01%
P-1045B	138	0.01%
P-1046	158	0.01%
P-1047A	159	0.01%
P-1047B	146	0.01%
P-1048	158	0.01%
P-1049	146	0.01%
P-1050	158	0.01%

EXHIBIT B
Area of Units and Allocation of Interest in Common Elements

<u>Unit No.</u>	<u>Area (sq. ft.)</u>	<u>Allocation of Interest</u>
P-1051	158	0.01%
P-1052	191	0.01%
P-1053	191	0.01%
P-1054	163	0.01%
P-1055	163	0.01%
P-1056A	154	0.01%
P-1056B	133	0.01%
P-1057A	154	0.01%
P-1057B	133	0.01%
P-1058	139	0.01%
P-1059A	154	0.01%
P-1059B	133	0.01%
P-1060	139	0.01%
P-1061A	154	0.01%
P-1061B	133	0.01%
P-1062	137	0.01%
P-1063A	154	0.01%
P-1063B	133	0.01%
P-1064A	154	0.01%
P-1064B	133	0.01%
P-1065A	154	0.01%
P-1065B	133	0.01%
P-1066	137	0.01%
P-1067A	154	0.01%
P-1067B	133	0.01%
P-1068	146	0.01%
P-1069A	154	0.01%
P-1069B	131	0.01%
P-1070A	163	0.01%
P-1070B	138	0.01%
P-1071A	154	0.01%
P-1071B	133	0.01%
P-1072	149	0.01%
P-1073	149	0.01%
P-1074	151	0.01%
P-1075	151	0.01%
P-1076	140	0.01%
P-1077	140	0.01%
P-1078	143	0.01%
P-1079	149	0.01%
P-1080	149	0.01%
P-1081	143	0.01%

EXHIBIT B
Area of Units and Allocation of Interest in Common Elements

<u>Unit No.</u>	<u>Area (sq. ft.)</u>	<u>Allocation of Interest</u>
P-1082	142	0.01%
P-1083	142	0.01%
P-1084	142	0.01%
P-1085	132	0.01%
P-1086	152	0.01%
P-1087	141	0.01%
P-1088	142	0.01%
P-1089	135	0.01%
P-1090	142	0.01%
P-1091	135	0.01%
P-1092	142	0.01%
P-1093	135	0.01%
P-1094	142	0.01%
P-1095	135	0.01%
P-1096	142	0.01%
P-1097	135	0.01%
P-1098	142	0.01%
P-1099	135	0.01%
P-1100	142	0.01%
P-1101	135	0.01%
P-1102	142	0.01%
P-1103	135	0.01%
P-1104	142	0.01%
P-1105	135	0.01%
P-1106	142	0.01%
P-1107	135	0.01%
P-1108	142	0.01%
P-1109	135	0.01%
P-1110	170	0.01%
P-1111	167	0.01%
P-1112	170	0.01%
P-1113	167	0.01%
P-1114	146	0.01%
P-1115	143	0.01%
P-1116	153	0.01%
P-1117	143	0.01%
P-2001	150	0.01%
P-2002	150	0.01%
P-2003	176	0.01%
P-2004	176	0.01%
P-2005	159	0.01%
P-2006	165	0.01%

EXHIBIT B
Area of Units and Allocation of Interest in Common Elements

<u>Unit No.</u>	<u>Area (sq. ft.)</u>	<u>Allocation of Interest</u>
P-2007	165	0.01%
P-2008	140	0.01%
P-2009	145	0.01%
P-2010	140	0.01%
P-2011	142	0.01%
P-2012	133	0.01%
P-2013	162	0.01%
P-2014	171	0.01%
P-2015	162	0.01%
P-2016	162	0.01%
P-2017	168	0.01%
P-2018	168	0.01%
P-2019	216	0.01%
P-2020	153	0.01%
P-2021	193	0.01%
P-2022	153	0.01%
P-2023	193	0.01%
P-2024	153	0.01%
P-2025	153	0.01%
P-2026	153	0.01%
P-2027	153	0.01%
P-2028	153	0.01%
P-2029	159	0.01%
P-2030	153	0.01%
P-2031	159	0.01%
P-2032	153	0.01%
P-2033	152	0.01%
P-2034	153	0.01%
P-2035	152	0.01%
P-2036	153	0.01%
P-2037	159	0.01%
P-2038	153	0.01%
P-2039	153	0.01%
P-2040	153	0.01%
P-2041	153	0.01%
P-2042	153	0.01%
P-2043	153	0.01%
P-2044	153	0.01%
P-2045A	146	0.01%
P-2045B	138	0.01%
P-2046	153	0.01%
P-2047A	146	0.01%

EXHIBIT B
Area of Units and Allocation of Interest in Common Elements

<u>Unit No.</u>	<u>Area (sq. ft.)</u>	<u>Allocation of Interest</u>
P-2047B	138	0.01%
P-2048	158	0.01%
P-2049A	153	0.01%
P-2049B	144	0.01%
P-2050	158	0.01%
P-2051	149	0.01%
P-2052	158	0.01%
P-2053	158	0.01%
P-2054	184	0.01%
P-2055	184	0.01%
P-2056	157	0.01%
P-2057	157	0.01%
P-2058A	149	0.01%
P-2058B	142	0.01%
P-2059A	149	0.01%
P-2059B	142	0.01%
P-2060A	150	0.01%
P-2060B	133	0.01%
P-2061A	149	0.01%
P-2061B	142	0.01%
P-2062A	150	0.01%
P-2062B	133	0.01%
P-2063A	149	0.01%
P-2063B	142	0.01%
P-2064A	158	0.01%
P-2064B	140	0.01%
P-2065A	149	0.01%
P-2065B	142	0.01%
P-2066A	149	0.01%
P-2066B	142	0.01%
P-2067A	149	0.01%
P-2067B	142	0.01%
P-2068	148	0.01%
P-2069A	149	0.01%
P-2069B	142	0.01%
P-2070A	148	0.01%
P-2070B	145	0.01%
P-2071A	149	0.01%
P-2071B	139	0.01%
P-2072A	157	0.01%
P-2072B	147	0.01%
P-2073A	149	0.01%

EXHIBIT B
Area of Units and Allocation of Interest in Common Elements

<u>Unit No.</u>	<u>Area (sq. ft.)</u>	<u>Allocation of Interest</u>
P-2073B	142	0.01%
P-2074	150	0.01%
P-2075	150	0.01%
P-2076	174	0.01%
P-2077	174	0.01%
P-2078	144	0.01%
P-2079	156	0.01%
P-2080	144	0.01%
P-2081	156	0.01%
P-2082	144	0.01%
P-2083	140	0.01%
P-2084	140	0.01%
P-2085	143	0.01%
P-2086	149	0.01%
P-2087	149	0.01%
P-2088	142	0.01%
P-2089	143	0.01%
P-2090	142	0.01%
P-2091	132	0.01%
P-2092	142	0.01%
P-2093	141	0.01%
P-2094	152	0.01%
P-2095	135	0.01%
P-2096	142	0.01%
P-2097	135	0.01%
P-2098	142	0.01%
P-2099	135	0.01%
P-2100	142	0.01%
P-2101	135	0.01%
P-2102	142	0.01%
P-2103	135	0.01%
P-2104	142	0.01%
P-2105	135	0.01%
P-2106	142	0.01%
P-2107	135	0.01%
P-2108	142	0.01%
P-2109	135	0.01%
P-2110	142	0.01%
P-2111	135	0.01%
P-2112	142	0.01%
P-2113	135	0.01%
P-2114	142	0.01%

EXHIBIT B
Area of Units and Allocation of Interest in Common Elements

<u>Unit No.</u>	<u>Area (sq. ft.)</u>	<u>Allocation of Interest</u>
P-2115	135	0.01%
P-2116	142	0.01%
P-2117	167	0.01%
P-2118	155	0.01%
P-2119	167	0.01%
P-2120	155	0.01%
P-2121	146	0.01%
P-2122	143	0.01%
P-2123	143	0.01%
P-2124	143	0.01%
P-2125	153	0.01%
P-2126	143	0.01%
		0.01%
<i>Storage</i>		0.01%
S-121	77	0.01%
S-122	42	0.01%
S-123	43	0.01%
S-124	36	0.01%
S-125	60	0.01%
S-126	64	0.01%
S-127	60	0.01%
S-128	64	0.01%
S-129	63	0.01%
S-130	44	0.01%
S-131	45	0.01%
S-132	44	0.01%
S-133	45	0.01%
S-134	77	0.01%
S-135	73	0.01%
S-136	82	0.01%
S-137	73	0.01%
S-138	79	0.01%
S-139	73	0.01%
S-140	127	0.01%
S-142	127	0.01%
S-143	87	0.01%
S-160	43	0.01%
S-161	46	0.01%
S-222	59	0.01%
S-223	63	0.01%
S-224	49	0.01%
S-225	63	0.01%

EXHIBIT B
Area of Units and Allocation of Interest in Common Elements

<u>Unit No.</u>	<u>Area (sq. ft.)</u>	<u>Allocation of Interest</u>
S-227	63	0.01%
S-229	63	0.01%
S-230	61	0.01%
S-231	63	0.01%
S-232	52	0.01%
S-233	63	0.01%
S-234	44	0.01%
S-235	63	0.01%
S-236	44	0.01%
S-238	88	0.01%
S-239	63	0.01%
S-240	84	0.01%
S-241	63	0.01%
S-242	71	0.01%
S-243	49	0.01%
S-244	72	0.01%
S-245	49	0.01%
S-249	80	0.01%
S-250	77	0.01%
S-251	80	0.01%
S-252	81	0.01%
S-253	63	0.01%
S-254	83	0.01%
S-255	81	0.01%
S-280	39	0.01%
S-281	35	0.01%
S-B103	63	0.01%
S-B104	55	0.01%
S-B105	55	0.01%
S-B106	56	0.01%
S-B107	56	0.01%
S-B108	55	0.01%
S-B109	55	0.01%
S-B110	63	0.01%
S-B111	91	0.01%
S-B112	75	0.01%
S-B113	67	0.01%
S-B114	62	0.01%
S-B115	61	0.01%
S-B116	56	0.01%
S-B117	55	0.01%
S-B118	58	0.01%

EXHIBIT B
Area of Units and Allocation of Interest in Common Elements

<u>Unit No.</u>	<u>Area (sq. ft.)</u>	<u>Allocation of Interest</u>
S-B120	87	0.01%
S-B121	87	0.01%
S-B122	88	0.01%
S-B123	78	0.01%
S-B124	77	0.01%
S-B125	76	0.01%
S-B126	81	0.01%
S-B127	54	0.01%
S-B128	50	0.01%
S-B129	65	0.01%
S-B130	43	0.01%
S-B131	46	0.01%
S-B132	90	0.01%
S-B133	94	0.01%
S-B134	80	0.01%
S-B135	75	0.01%
S-B136	77	0.01%
S-B137	77	0.01%
S-B138	76	0.01%
S-B139	108	0.01%
S-B140	120	0.01%
S-B142	110	0.01%
S-B145	72	0.01%
S-B146	59	0.01%
S-B147	74	0.01%
S-B148	80	0.01%
S-B151	58	0.01%
S-B203	63	0.01%
S-B204	55	0.01%
S-B205	55	0.01%
S-B206	56	0.01%
S-B207	56	0.01%
S-B208	55	0.01%
S-B209	55	0.01%
S-B210	63	0.01%
S-B211	91	0.01%
S-B212	75	0.01%
S-B213	67	0.01%
S-B214	62	0.01%
S-B215	61	0.01%
S-B216	56	0.01%
S-B217	55	0.01%

EXHIBIT B
Area of Units and Allocation of Interest in Common Elements

<u>Unit No.</u>	<u>Area (sq. ft.)</u>	<u>Allocation of Interest</u>
S-B218	54	0.01%
S-B219	90	0.01%
S-B220	87	0.01%
S-B221	87	0.01%
S-B222	88	0.01%
S-B223	78	0.01%
S-B224	77	0.01%
S-B225	76	0.01%
S-B226	81	0.01%
S-B227	54	0.01%
S-B228	50	0.01%
S-B229	65	0.01%
S-B230	43	0.01%
S-B231	46	0.01%
S-B232	94	0.01%
S-B233	90	0.01%
S-B234	80	0.01%
S-B235	75	0.01%
S-B236	77	0.01%
S-B237	77	0.01%
S-B238	76	0.01%
S-B239	108	0.01%
S-B240	120	0.01%
S-B241	68	0.01%
S-B242	44	0.01%
S-B243	87	0.01%
S-B244	48	0.01%
S-B245	69	0.01%
S-B246	62	0.01%
S-B247	74	0.01%
S-B248	80	0.01%
S-B250	55	0.01%
S-B251	48	0.01%
S-B254	58	0.01%
S-B260	63	0.01%
S-B261	63	0.01%
S-B262	63	0.01%
S-B263	62	<u>0.01%</u>
Total:		100.00%

EXHIBIT C-1

Listing of Retail and Residential Expenses

**THE ELIOT CONDOMINIUM
INITIAL PROPOSED OPERATING BUDGET**

CMI/10/TEC

<u>CODE</u>	<u>INCOME</u>	<u>INITIAL PROPOSED RESIDENTIAL BUDGET</u>	<u>INITIAL PROPOSED RETAIL BUDGET</u>	<u>INITIAL PROPOSED SHARED BUDGET</u>	<u>COMBINED INITIAL PROPOSED MONTHLY BUDGET</u>	<u>COMBINED INITIAL PROPOSED ANNUAL BUDGET</u>
5000	HOMEOWNERS DUES	3,052.00	256.00	87,841.00	91,149.00	1,093,788.00
	TOTAL INCOME	3,052.00	256.00	87,841.00	91,149.00	1,093,788.00
	EXPENSE ITEM					
6060	ELECTRIC			5,104.00	5,104.00	61,248.00
6090	GARBAGE	795.00			795.00	9,540.00
6105	GAS			4,640.00	4,640.00	55,680.00
6150	SEWER			4,060.00	4,060.00	48,720.00
6180	TELEPHONE	175.00		280.00	455.00	5,460.00
6195	WATER			3,480.00	3,480.00	41,760.00
6390	PLAZA	81.00	244.00		325.00	3,900.00
6465	ELEVATOR MAINTENANCE			2,205.00	2,205.00	26,460.00
6525	GARAGE MAINTENANCE			179.00	179.00	2,148.00
6555	HVAC SYSTEM			1,350.00	1,350.00	16,200.00
6585	JANITORIAL/SUPPLIES EXPENSE			8,970.00	8,970.00	107,640.00
6675	PEST CONTROL			105.00	105.00	1,260.00
6690	BUILDING MAINTENANCE			7,500.00	7,500.00	90,000.00
6735	ROOF REPAIRS			210.00	210.00	2,520.00
6765	SECURITY			1,262.00	1,262.00	15,144.00
6885	WINDOW CLEANING			2,590.00	2,590.00	31,080.00
7060	ALARM SYSTEM			35.00	35.00	420.00
7105	ASSOCIATION OPERATIONS			840.00	840.00	10,080.00
7120	INSPECTIONS			1,000.00	1,000.00	12,000.00
7225	INSURANCE			10,775.00	10,775.00	129,300.00
7255	LEGAL			158.00	158.00	1,896.00
7300	MANAGEMENT FEE			4,200.00	4,200.00	50,400.00
7450	CONCIERGE			16,770.00	16,770.00	201,240.00
7465	TAXES, LICENSE, FEES & AUDITS			507.00	507.00	6,084.00
7675	LANDSCAPE			420.00	420.00	5,040.00
7750	MAINTENANCE COORDINATOR			2,600.00	2,600.00	31,200.00
	TOTAL FROM OPERATIONS	1,051.00	244.00	79,240.00	80,535.00	966,420.00
	GENERAL RESERVES	0.00	0.00	0.00	0.00	0.00
	CAPITAL REPLACEMENT RESERVES	2,001.00	12.00	8,601.00	10,614.00	127,368.00
	TOTAL OPERATIONS & RESERVES	3,052.00	256.00	87,841.00	91,149.00	1,093,788.00

These projections are subject to increase or decrease to reflect changes in operating policies, and/or level of service, inflation or other causes. These projections are only estimates, prepared with due care.

NOTE: Expenses shared by both retail and residential units are allocated 2.91% to the retail units and 97.09% to the residential units.

COMMUNITY MANAGEMENT, INC.
4/12/2006

EXHIBIT C-2
Allocation of Retail Expenses

<u>Unit No.</u>	<u>Area (sq. ft.)</u>	<u>Allocation of Expenses</u>
R-1	3,108	33.72%
R-2	4,790	51.96%
R-3	1,320	<u>14.32%</u>
Total:		100.00%

EXHIBIT C-3
Allocation of Residential Expenses

<u>Unit No.</u>	<u>Area of Unit</u>	<u>Area of Patio</u>	<u>Total Area</u>	<u>Allocation of Expenses</u>
101	953	237	1,190	0.41%
102	942	175	1,117	0.36%
103	1,498	286	1,784	0.58%
104	1,512	286	1,798	0.59%
105	1,512	286	1,798	0.59%
106	1,535	261	1,796	0.58%
107	763	104	867	0.28%
108	773	113	886	0.29%
109	773	113	886	0.29%
110	791	104	895	0.29%
201	1,523	0	1,523	0.50%
202	832	0	832	0.27%
203	842	0	842	0.27%
204	840	0	840	0.27%
205	748	0	748	0.24%
206	1,525	0	1,525	0.50%
207	1,138	0	1,138	0.37%
208	1,145	0	1,145	0.37%
209	922	33	955	0.31%
210	775	0	775	0.25%
211	742	0	742	0.24%
212	734	0	734	0.24%
213	726	0	726	0.24%
214	690	0	690	0.22%
215	685	0	685	0.22%
216	685	0	685	0.22%
217	724	0	724	0.24%
218	936	0	936	0.30%
219	1,025	0	1,025	0.33%
220	891	0	891	0.29%
302	1,822	303	2,125	0.69%
303	798	182	980	0.32%
304	854	202	1,056	0.34%
305	1,854	202	2,056	0.67%
306	1,134	0	1,134	0.37%
307	916	40	956	0.31%
308	827	141	968	0.32%
309	831	149	980	0.32%
310	878	0	878	0.29%
311	847	0	847	0.28%
312	817	0	817	0.27%
313	1,302	344	1,646	0.54%

EXHIBIT C-3
Allocation of Residential Expenses

<u>Unit No.</u>	<u>Area of Unit</u>	<u>Area of Patio</u>	<u>Total Area</u>	<u>Allocation of Expenses</u>
314	508	0	508	0.17%
315	771	0	771	0.25%
316	739	0	739	0.24%
317	730	0	730	0.24%
318	722	0	722	0.23%
401	2,038	37	2,075	0.68%
402	1,378	0	1,378	0.45%
403	853	0	853	0.28%
404	907	0	907	0.30%
405	2,135	41	2,176	0.71%
406	1,568	178	1,746	0.57%
407	1,396	141	1,537	0.50%
408	872	46	918	0.30%
409	872	74	946	0.31%
410	916	74	990	0.32%
411	893	74	967	0.31%
412	857	74	931	0.30%
413	1,487	121	1,608	0.52%
414	559	0	559	0.18%
501	2,056	37	2,093	0.68%
502	1,379	0	1,379	0.45%
503	853	0	853	0.28%
504	908	0	908	0.30%
505	2,144	41	2,185	0.71%
506	1,568	37	1,605	0.52%
507	1,346	36	1,382	0.45%
508	872	46	918	0.30%
509	872	74	946	0.31%
510	916	74	990	0.32%
511	893	74	967	0.31%
512	857	74	931	0.30%
513	1,487	121	1,608	0.52%
514	559	0	559	0.18%
601	2,050	37	2,087	0.68%
602	1,378	0	1,378	0.45%
603	859	0	859	0.28%
604	915	0	915	0.30%
605	2,137	41	2,178	0.71%
606	1,568	37	1,605	0.52%
607	1,346	36	1,382	0.45%
608	872	46	918	0.30%
609	872	74	946	0.31%

EXHIBIT C-3
Allocation of Residential Expenses

<u>Unit No.</u>	<u>Area of Unit</u>	<u>Area of Patio</u>	<u>Total Area</u>	<u>Allocation of Expenses</u>
610	916	74	990	0.32%
611	893	74	967	0.31%
612	857	74	931	0.30%
613	1,487	121	1,608	0.52%
614	559	0	559	0.18%
701	2,056	37	2,093	0.68%
702	1,379	0	1,379	0.45%
703	853	0	853	0.28%
704	908	0	908	0.30%
705	2,144	41	2,185	0.71%
706	1,568	37	1,605	0.52%
707	1,346	36	1,382	0.45%
708	872	46	918	0.30%
709	872	74	946	0.31%
710	916	74	990	0.32%
711	893	74	967	0.31%
712	857	74	931	0.30%
713	1,487	121	1,608	0.52%
714	559	0	559	0.18%
801	2,050	37	2,087	0.68%
802	1,378	0	1,378	0.45%
803	859	0	859	0.28%
804	915	0	915	0.30%
805	2,137	41	2,178	0.71%
806	1,568	37	1,605	0.52%
807	1,346	36	1,382	0.45%
808	868	46	914	0.30%
809	865	74	939	0.31%
810	916	74	990	0.32%
811	893	74	967	0.31%
812	857	74	931	0.30%
813	1,487	121	1,608	0.52%
814	559	0	559	0.18%
901	2,056	37	2,093	0.68%
902	1,379	0	1,379	0.45%
903	853	0	853	0.28%
904	908	0	908	0.30%
905	2,144	41	2,185	0.71%
906	1,568	37	1,605	0.52%
907	1,346	36	1,382	0.45%
908	868	46	914	0.30%
909	865	74	939	0.31%

EXHIBIT C-3
Allocation of Residential Expenses

<u>Unit No.</u>	<u>Area of Unit</u>	<u>Area of Patio</u>	<u>Total Area</u>	<u>Allocation of Expenses</u>
910	916	74	990	0.32%
911	891	74	965	0.31%
912	857	74	931	0.30%
913	1,487	121	1,608	0.52%
914	559	0	559	0.18%
1001	2,050	37	2,087	0.68%
1002	1,378	0	1,378	0.45%
1003	859	0	859	0.28%
1004	915	0	915	0.30%
1005	2,137	41	2,178	0.71%
1006	1,568	37	1,605	0.52%
1007	1,346	36	1,382	0.45%
1008	868	46	914	0.30%
1009	865	74	939	0.31%
1010	916	74	990	0.32%
1011	891	74	965	0.31%
1012	857	74	931	0.30%
1013	1,487	121	1,608	0.52%
1014	559	0	559	0.18%
1101	2,067	37	2,104	0.68%
1102	1,381	0	1,381	0.45%
1103	848	0	848	0.28%
1104	903	0	903	0.29%
1105	2,149	41	2,190	0.71%
1106	1,570	37	1,607	0.52%
1107	1,351	36	1,387	0.45%
1108	870	46	916	0.30%
1109	865	74	939	0.31%
1110	1,360	111	1,471	0.48%
1112	1,319	112	1,431	0.47%
1113	1,500	121	1,621	0.53%
1114	568	0	568	0.18%
1201	2,060	37	2,097	0.68%
1202	1,380	0	1,380	0.45%
1203	854	0	854	0.28%
1204	910	0	910	0.30%
1205	2,144	41	2,185	0.71%
1206	1,570	37	1,607	0.52%
1207	1,351	36	1,387	0.45%
1208	870	46	916	0.30%
1209	866	74	940	0.31%
1210	1,360	111	1,471	0.48%

EXHIBIT C-3
Allocation of Residential Expenses

<u>Unit No.</u>	<u>Area of Unit</u>	<u>Area of Patio</u>	<u>Total Area</u>	<u>Allocation of Expenses</u>
1212	1,319	112	1,431	0.47%
1213	1,500	121	1,621	0.53%
1214	568	0	568	0.18%
1301	2,067	37	2,104	0.68%
1302	1,381	0	1,381	0.45%
1303	854	0	854	0.28%
1304	910	0	910	0.30%
1305	2,151	41	2,192	0.71%
1306	1,570	37	1,607	0.52%
1307	1,355	36	1,391	0.45%
1308	870	46	916	0.30%
1309	865	74	939	0.31%
1310	1,372	111	1,483	0.48%
1312	1,338	112	1,450	0.47%
1313	1,500	121	1,621	0.53%
1314	568	0	568	0.18%
1401	2,060	37	2,097	0.68%
1402	1,380	0	1,380	0.45%
1403	860	0	860	0.28%
1404	916	0	916	0.30%
1405	2,144	41	2,185	0.71%
1406	1,570	37	1,607	0.52%
1407	1,355	36	1,391	0.45%
1408	870	46	916	0.30%
1409	865	74	939	0.31%
1410	1,372	111	1,483	0.48%
1412	1,338	112	1,450	0.47%
1413	1,500	121	1,621	0.53%
1414	568	0	568	0.18%
1501	2,072	37	2,109	0.69%
1502	1,381	0	1,381	0.45%
1503	863	0	863	0.28%
1504	830	65	895	0.29%
1505	1,731	361	2,092	0.68%
1506	1,570	37	1,607	0.52%
1507	1,355	36	1,391	0.45%
1508	865	46	911	0.30%
1509	865	74	939	0.31%
1510	1,364	111	1,475	0.48%
1512	1,333	112	1,445	0.47%
1513	1,503	121	1,624	0.53%
1514	568	0	568	0.18%

EXHIBIT C-3
Allocation of Residential Expenses

<u>Unit No.</u>	<u>Area of Unit</u>	<u>Area of Patio</u>	<u>Total Area</u>	<u>Allocation of Expenses</u>
1601	4,377	45	4,422	1.44%
1603	2,595	483	3,078	1.00%
1604	2,957	74	3,031	0.99%
1605	1,519	177	1,696	0.55%
1606	1,588	191	1,779	0.58%
1607	2,351	557	2,908	0.95%
1701	2,620	49	2,669	0.87%
1702	1,722	0	1,722	0.56%
1703	2,593	441	3,034	0.99%
1704	2,964	74	3,038	0.99%
1705	1,526	133	1,659	0.54%
1706	1,594	144	1,738	0.57%
1707	2,356	220	2,576	0.84%
1801	4,387	49	4,436	1.44%
1803	2,594	483	3,077	1.00%
1804	2,958	74	3,032	0.99%
1805	1,528	133	1,661	0.54%
1806	1,590	144	1,734	0.56%
1807	2,332	220	2,552	<u>0.83%</u>
Total:				100.00%

**BYLAWS
OF
ELIOT TOWER CONDOMINIUMS OWNERS' ASSOCIATION**

TABLE OF CONTENTS

	<u>Page</u>
1. GENERAL PROVISIONS	1
1.1 Identity	1
1.2 Bylaws Subject to Other Documents	1
1.3 Defined Terms	1
1.4 Applicability	1
1.5 Office	1
2. MEETINGS OF OWNERS	1
2.1 Administrative Control	1
2.2 Transitional Committee	1
2.3 Turnover Meeting	2
2.4 Annual Meetings	2
2.5 Place of Meetings	2
2.6 Special Meetings	3
2.7 Notice	3
2.8 Voting	3
2.9 Proxies	4
2.10 Fiduciary, Corporate and Joint Owners	4
2.11 Quorum	4
2.12 Binding Vote	5
2.13 Order of Business	5
2.14 Rules of Order	5
3. BOARD OF DIRECTORS	5
3.1 Number, Term and Qualification	5
3.2 Powers and Duties	6
3.3 Limitation	9
3.4 Organizational Meeting	9
3.5 Regular and Special Meetings	9
3.6 Waiver of Notice	10
3.7 Quorum	10
3.8 Removal	11
3.9 Resignation	11
3.10 Vacancies	11
3.11 Compensation	11
3.12 Liability and Indemnification of Directors, Officers, Manager or Managing Agent	11
3.13 Insurance	11
3.14 Special Committees	12

4.	OFFICERS.....	12
4.1	Designation.....	12
4.2	Election.....	12
4.3	Removal.....	12
4.4	Chairperson.....	12
4.5	Vice Chairperson.....	12
4.6	Secretary.....	13
4.7	Treasurer.....	13
4.8	Execution of Instruments.....	13
4.9	Compensation of Officers.....	13
5.	BUDGET, EXPENSES AND ASSESSMENTS.....	13
5.1	Budget.....	13
5.2	Reserve Fund for Replacing Common Elements.....	14
5.3	Determination of Common Expenses.....	15
5.4	Assessment of Common Expenses.....	16
5.5	Special Assessments.....	17
5.6	Violation by Owners; Remedies.....	18
5.7	Liability of Owners.....	18
5.8	No Waiver.....	19
5.9	Receiver.....	19
6.	RECORDS AND AUDITS.....	19
6.1	General Records.....	19
6.2	Records of Receipts and Expenditures.....	19
6.3	Assessment Roll.....	20
6.4	Payment of Vouchers.....	20
6.5	Reports and Audits.....	20
6.6	Notice of Sale, Mortgage, Rental or Lease.....	20
6.7	Statement of Assessments.....	20
7.	OCCUPATION AND USE.....	20
7.1	Rental.....	20
7.2	Residential Use.....	22
7.3	Commercial Use.....	22
7.4	Insurance Risk.....	23
7.5	Compliance.....	23
7.6	Alterations.....	23
7.7	Occupants of Corporate Unit.....	24
7.8	Non-Interference.....	24
7.9	Nuisances.....	24
7.10	Unlawful or Improper Activities.....	25
7.11	Contested Legal Requirements.....	25
7.12	Improper Discharge.....	25
7.13	Limitation on Storage Areas.....	26
7.14	Tradesmen.....	26

7.15	Animals.....	26
7.16	Signs and Displays.....	26
7.17	Sidewalk Areas.....	27
7.18	Trash.....	27
7.19	Auctions or Open House.....	27
7.20	Overloading.....	27
7.21	Hot Tubs.....	27
7.22	Exercise, Library and Meeting Rooms.....	27
7.23	Courtyard.....	28
7.24	Window Coverings.....	28
7.25	Patios.....	28
7.26	Over-the-Air Reception Devices.....	28
7.27	Association Rules and Regulations.....	29
7.28	Activities of Declarant.....	29
7.29	Entry System.....	29
8.	MAINTENANCE OF CONDOMINIUM PROPERTY; CONDEMNATION.....	29
8.1	Maintenance and Repair.....	29
8.2	Additions, Alterations, or Improvements.....	31
8.3	Failure to Follow Maintenance Plan.....	31
9.	INSURANCE.....	31
9.1	Types.....	31
9.2	Mandatory Policy Provisions.....	33
9.3	Discretionary Provisions.....	34
9.4	Additional Requirements.....	35
9.5	By the Owner.....	36
9.6	FannieMae and GNMA Requirements.....	37
10.	AMENDMENTS TO BYLAWS.....	37
10.1	How Proposed.....	37
10.2	Adoption.....	37
10.3	Execution and Recording.....	38
10.4	Rights of Declarant.....	38
11.	LITIGATION.....	38
11.1	By Less than All Owners.....	38
11.2	Complaints Against.....	38
11.3	Mediation.....	38
11.4	Limitations on Actions.....	39
11.5	No Attorneys' Fees.....	39
11.6	Suits Against Declarant.....	39
11.7	Initial Dispute Resolution Procedures.....	39
11.8	Reports on Litigation.....	39

12.	MISCELLANEOUS	39
12.1	Notices	39
12.2	Waiver.....	40
12.3	Invalidity, Number, Captions	40
12.4	Action Without a Meeting	40
12.5	Conflicts.....	40
12.6	Liability Survives Termination.....	40
12.7	Indexing	40
12.8	Declarant as Owner.....	41

BYLAWS

OF

ELIOT TOWER CONDOMINIUMS OWNERS' ASSOCIATION

1. GENERAL PROVISIONS.

1.1 Identity. Eliot Tower Condominiums Owners' Association, a nonprofit corporation organized under the laws of the State of Oregon, the Articles of Incorporation of which were filed in the Office of the Oregon Corporation Commissioner on the 9th day of February, 2006 (the "Association"), has been organized for the purpose of administering the operation and management of Eliot Tower Condominiums (the "Condominium"), in accordance with the terms of these Bylaws. The Condominium was established by Eliot Tower LLC, an Oregon limited liability company (the "Declarant"), in accordance with the provisions of ORS Chapter 100 (the "Act"). The Condominium is located upon property in Multnomah County, Oregon, as more particularly described in the Declaration of Condominium Ownership for Eliot Tower Condominiums (the "Declaration"), which is being recorded simultaneously herewith in the records of Multnomah County, Oregon.

1.2 Bylaws Subject to Other Documents. The provisions of these Bylaws are applicable to the Condominium and are expressly subject to the terms, provisions, and conditions contained in the Articles of Incorporation of the Association (the "Articles") and in the Declaration.

1.3 Defined Terms. All defined terms used in these Bylaws and not specifically defined herein shall have the meaning given such terms in the Declaration.

1.4 Applicability. All Owners; tenants and occupants of any Unit; and their respective agents, servants, invitees, licensees, and employees that use the Condominium, or any part thereof, are subject to these Bylaws, and all rules and regulations thereunder as promulgated from time to time.

1.5 Office. The office of the Association shall be at 420 NW 11th Avenue, Suite 1004, Portland, Oregon 97209, or at any other place within Portland, Oregon designated by the Association.

2. MEETINGS OF OWNERS.

2.1 Administrative Control. Notwithstanding any other provisions of these Bylaws, until the Turnover Meeting, the Declarant shall have the powers and authorities reserved to the Declarant in Section 21 of the Declaration.

2.2 Transitional Committee. Unless the Turnover Meeting has been held, the Declarant shall call a meeting of the Owners within 60 days after the conveyance to persons other than the Declarant of 50 percent of all 661 Units. Notice of the meeting shall be given as provided in Section 2.7 to each Owner at least seven but not more than 50 days prior to the meeting. The notice shall state the purpose, time, and place of the meeting. If the meeting is not called by the Declarant within the time specified, the meeting may be called and notice given by

any Owner. If at the meeting the Owners other than the Declarant fail to select a transitional committee (the "Transitional Committee"), the Declarant shall have no further responsibility to form such a committee. The Transitional Committee shall be advisory only and shall consist of two or more members selected by Owners other than the Declarant and shall not include more than one representative of the Declarant. The members of the Transitional Committee shall serve until the Turnover Meeting. The Transitional Committee shall function to ease the transition from control of the administration of the Association by the Declarant to control by the Owners. The Transitional Committee shall have access to the information, documents, and records that the Declarant must turn over to the Owners pursuant to Section 2.3.

2.3 Turnover Meeting. The Turnover Meeting, which shall constitute the initial meeting of the Association, shall be called by the Declarant within 90 days of the expiration of the period of Declarant's administrative control described in Section 21 of the Declaration. The Declarant shall give notice (as provided in Section 2.7) of the Turnover Meeting to each Owner at least 10 but not more than 50 days prior to the meeting. The notice shall state the purpose, time, and place of the meeting. If the meeting is not called by the Declarant, the meeting may be called and notice given by any Owner or by any first Mortgagee of a Unit. At the Turnover Meeting, the Declarant shall relinquish control of the administration of the Association to the Owners and the latter shall assume control; the Owners shall elect a board of directors as set forth in these Bylaws; and the Declarant shall deliver to the Association the items specified in Section 100.210(5) of the Act. During the three-month period following the Turnover Meeting, the Declarant or an informed representative thereof shall be available to meet with the Board on at least three mutually acceptable dates to review the documents delivered pursuant to Section 100.210(5)(3) of the Act. If the Declarant has complied with the terms of Section 100.210 of the Act, then, unless the Declarant otherwise has sufficient voting rights as an Owner to control the Association, the Declarant shall not be responsible for the failure of the Owners to comply with the provisions of Section 100.210(4) of the Act, and the Declarant shall be relieved of any further responsibility for the administration of the Association except as an Owner for any unsold Unit.

2.4 Annual Meetings. In the twelfth month following the month in which the Turnover Meeting is held, the first annual meeting of Owners shall be held. At such meeting, the seven (7) incumbent directors of the Association (any director of the Association, a "Director") elected at the Turnover Meeting shall resign and seven directors (who may have previously served as Directors) shall be elected by the Owners in accordance with these Bylaws. Thereafter, annual meetings shall be held in the same month as the initial annual meeting or in the month following, at such hour and on such date as the Chairperson of the Board of Directors (the "Chairperson") may designate or, if the Chairperson fails to designate such date by the last day of the first month in which the meeting may be held, the meeting shall be held on the second Wednesday of the second month in which the meeting may be held, unless such date shall be a legal holiday, in which event the meeting shall be held on the next succeeding business day. At such meetings, the Owners shall elect Directors to fill vacancies or to succeed retiring Directors as provided in Article 3 of these Bylaws and shall also transact such other business of the Association as may properly come before the meeting.

2.5 Place of Meetings. Meetings of the Owners shall be held at the principal office of the Association or at such other suitable and convenient place within the City of Portland, Oregon, as may be designated by the Board.

2.6 Special Meetings. It shall be the duty of the Chairperson to call a special meeting of the Association if the Chairperson so elects or if so directed by resolution of the Board or upon a petition signed and presented to the secretary of the Association (the "Secretary") by the Owners of not less than 35 percent of the Primary Units stating the purpose of the meeting. The notice of any special meeting shall state the purpose, time, and place of such meeting. No business shall be transacted at a special meeting except as stated in the notice.

2.7 Notice. The Chairperson or Secretary shall give written notice of each meeting of the Association, at least 10 days but not more than 50 days prior to the date set for such meeting, stating the purpose, time, and place of the meeting and the items on the agenda (including the general nature of any proposed amendment to the Declaration or these Bylaws, any budget changes or proposal to remove a director or officer of the Association), to each Owner of record (and to any first Mortgagee of record requesting such notice), at the address of such Owner as listed on the books of the Association, or at such other address as such Owner shall have designated by notice in writing to the Chairperson or Secretary at least 10 days prior to the giving of such notice by the Chairperson or Secretary. The giving of a notice in the manner provided in these Bylaws shall be considered notice properly served. Proof of the giving of such notice, whether by mail or personal delivery, shall be given by the affidavit of the person giving the notice. Notice of a meeting may be waived by any Owner before or after a meeting. For a period of 10 years following recording of the Declaration, notices of meetings shall also be given to Declarant in the same manner as given to Owners, and Declarant or a representative of Declarant shall be entitled to attend such meetings. When a meeting is adjourned for less than 30 days, no notice of the adjourned meeting need be given other than by announcement at the meeting at which such adjournment takes place.

2.8 Voting.

2.8.1 The total number of votes of all Owners shall be 239, which is equal to the total number of Residential Units in the Condominium, plus 10 votes total for the Retail Units, allocated as described in Section 8 of the Declaration, and each Owner or group of Owners shall be entitled, subject to the provisions of Section 21 of the Declaration (which grants Declarant five (5) times the votes for each Primary Unit owned by it prior to the Turnover Meeting) and to Section 3.1 of these Bylaws regarding the election of Directors, to a number of votes equal to the number of votes allocated to the Primary Units owned by such Owner or group of Owners in Section 8 of the Declaration. No voting rights shall be allocated to Parking Units or Storage Units. The Declarant shall be entitled to vote as the Owner of any Primary Units retained by the Declarant, and the Board shall be entitled to vote on behalf of any Primary Unit that has been acquired by or on behalf of the Association; provided, however, that the Board shall not be entitled to vote such Primary Units in any election of Directors. Notwithstanding the foregoing, the approval of a majority of the Owners of the Retail Units shall be required in order to pass a vote on a matter adversely impacting the rights or privileges of the Owners of the Retail Units.

2.8.2 If an Owner is in default under a first Mortgage on its Unit for 60 consecutive days or more and the Mortgage instrument signed by the Owner provides for such a pledge upon default, the Mortgagee shall automatically be authorized to declare at any time thereafter that the Unit Owner has pledged his or her vote on all issues to the Mortgagee during the continuance of the default. If the Board has been notified of any such pledge to a Mortgagee,

or in the event the record Owner or Owners have otherwise pledged their vote regarding special matters to a Mortgagee under a duly recorded Mortgage, only the vote of such Mortgagee or vendor will be recognized in regard to the special matters upon which the vote is so pledged, if a copy of the instrument with this pledge has been filed with the Board. Amendments to this subsection shall only be effective upon the written consent of all the voting Owners and their respective Mortgagees, if any.

2.8.3 If an Owner is in default for payment of assessments or other charges under these Bylaws, the Declaration or the Rules and Regulations for 60 consecutive days or more, the Owner's voting rights shall be suspended until such delinquencies are paid in full, including any interest, penalties or late charges due for such delinquency.

2.8.4 Voting of the Owners may be by written ballot in accordance with the Oregon Nonprofit Corporations Act; provided that the Owners may not take any action adversely affecting the Retail Units unless a majority of the affected Owners thereof are present at such meeting and approve of such action.

2.9 Proxies. A vote may be cast in person or by proxy. A proxy given by an Owner to any person who represents such Owner at meetings of the Association shall be in writing, signed by such Owner, may be given to any person or persons of legal age, and shall be filed with the Secretary. No proxy shall be valid after the meeting for which it was solicited, unless otherwise expressly stated in the proxy, and every proxy shall automatically cease upon sale of a Primary Unit by its Owner. An Owner may revoke such Owner's proxy only as provided in ORS 100.427. An Owner may pledge or assign such Owner's voting rights to a Mortgagee. In such case, the Mortgagee or its designated representative shall be entitled to receive all notices to which the Owner is entitled hereunder and to exercise the Owner's voting rights from and after the date that the Mortgagee shall give written notice of such pledge or assignment to the Board of Directors. Any first Mortgagee may designate a representative to attend all or any meetings of the Association.

2.10 Fiduciary, Corporate and Joint Owners. An executor, administrator, conservator, guardian or trustee may vote, in person or by proxy, at any meeting of the Owners with respect to any Primary Unit owned or held by him in such capacity, whether or not the same shall have been transferred to his name; provided, however, that he shall satisfy the Secretary that he is the executor, administrator, conservator, guardian or trustee holding such Unit in such capacity. Any person voting on behalf of a Primary Unit owned by a corporation or other entity shall provide the Secretary with written evidence, satisfactory to the Secretary, that such person is the duly constituted representative thereof. Unless a valid court order establishes the authority of a co-Owner to vote, whenever any Primary Unit is owned by two or more persons jointly, according to the records of the Association, the vote of such Unit may be exercised by any of the Owners then present, in the absence of protest by a co-Owner. In the event of disagreement among the co-Owners, the vote of such Unit shall be disregarded completely in determining the proportion of votes given with respect to the matter voted upon.

2.11 Quorum. At any meeting of the Association, the presence, in person or by proxy, of a number of Owners holding 20 percent or more of the voting power of the Association shall constitute a quorum. The subsequent joinder of an Owner in the action taken at a meeting, evidenced by that Owner signing and concurring in the minutes thereof, shall constitute the

presence of such person for the purpose of determining a quorum. When a quorum is once present to organize a meeting, it cannot be broken by the subsequent withdrawal of an Owner or Owners. If any meeting of the Association cannot be organized because of lack of a quorum, the Owners who are present, either in person or by proxy, may adjourn the meeting from time to time until a quorum is present; provided, however, that a quorum shall not be necessary to proceed with and hold a binding Turnover Meeting.

2.12 Binding Vote. The vote of more than 50 percent of the voting power present (whether in person or by proxy) at a meeting at which a quorum is constituted shall be binding upon all Owners for all purposes except where a higher percentage vote is required by law, the Declaration or these Bylaws.

2.13 Order of Business. The order of business at an annual meeting of the Association shall be:

2.13.1 Calling of the roll and certifying of proxies;

2.13.2 Proof of notice of meeting or waiver of notice;

2.13.3 Reading of minutes of preceding meeting;

2.13.4 Reports of officers;

2.13.5 Reports of committees, if any;

2.13.6 Election of directors;

2.13.7 Unfinished business;

2.13.8 New business; and

2.13.9 Adjournment.

2.14 Rules of Order. Unless other rules of order are adopted by resolution of the Association or the Board of Directors, all meetings of the Association shall be conducted according to the latest edition of *Roberts' Rules of Order* published by Robert's Rules Association.

3. BOARD OF DIRECTORS.

3.1 Number, Term and Qualification. The affairs of the Association shall be governed by the Board of Directors, which shall consist of from one (1) to three (3) persons prior to the Turnover Meeting and seven (7) persons after the Turnover Meeting. Until the Turnover Meeting (as provided for in Section 2.3 of these Bylaws) shall have been held, the Board of Directors shall consist of the Director or Directors named in the Articles of Incorporation of the Association, subject to the appointment and removal powers of the Declarant described in Section 21 of the Declaration. At the Turnover Meeting, six (6) Directors shall be elected by all Owners other than the Owners of the Retail Units (the "Residential Owners") to serve until the first annual meeting of the Association; and one Director shall be elected by the vote of the

Owners of the Retail Units (the "Retail Owners"). At the first annual meeting of the Association, three Directors shall be elected by the Residential Owners to serve for a term of two (2) years, three (3) Directors shall be elected by the Residential Owners to serve for a term of one (1) year, and the Director elected by the votes of the Retail Owners shall serve for a term of two (2) years. Election by the Residential Owners and Retail Owners shall be by plurality. At the expiration of the initial term of office of each Director elected at the first annual meeting of the Association, his or her successor shall be elected as provided in this Section 3.1 to serve for a term of two (2) years. The Directors shall hold office for the term herein fixed and until their successors have been qualified and elected. There shall be no limit on the number of successive terms a Director may serve on the Board of Directors, if elected as herein provided. After the Turnover Meeting, all Directors shall be Owners and no Director shall continue to serve on the Board of Directors after he or she ceases to be an Owner. For purposes of this Section 3.1, the officers of any corporation, the trustee of any trust, the partners of any partnership, or the members or managers, employees or designees of any limited liability company that owns a Primary Unit shall be considered co-owners of any such Unit.

3.2 Powers and Duties. The Board of Directors shall have the powers and duties necessary for the administration of the affairs of the Association and as provided by the Act and may do all acts in furtherance of and pursuant to such powers and duties, except acts that by or under law, the Declaration or these Bylaws may not be performed by the Board of Directors or delegated to the Board of Directors by the Owners. The Board of Directors shall be governed by ORS 100.417 and applicable provisions of ORS 65.357, 65.361, 65.367, 65.369 and 65.377. Such powers and duties of the Board of Directors shall include, without limitation (except as limited elsewhere herein), the following:

3.2.1 Operation, care, inspection, upkeep, repair, replacement and maintenance of the Common Elements, Parking Units and Association Property as required by the Declaration, these Bylaws, the YMCA Easement, the Madison Place Easement and by the Act. The Board shall prepare contemporaneous written documentation of the foregoing activities, which shall be made available to Owners and Declarant upon request.

3.2.2 Determination of the amounts required for inspection, operation, maintenance and other affairs of the Association, and the making of such expenditures, including, without limitation, the provision of concierge services for the Residential Units for such hours as may be determined by the Board of Directors, in the Board's sole discretion.

3.2.3 Annually conducting a reserve study, or review and update any existing study, of the Common Elements to determine the reserve fund requirements, in accordance with ORS 100.175.

3.2.4 Collection of the common expenses from the Owners.

3.2.5 Provision for the designation, hiring and removal of employees and other personnel, including lawyers and accountants and personnel necessary for the inspection, maintenance, upkeep and repair of the Common Elements, Parking Units and Association Property; engagement of or contracting for the services of others; and making purchases for the inspection, maintenance, repair, replacement, administration, management and operation of the Condominium and delegating any such powers to the manager or managing agent (and any such

employees or other personnel as may be employees of the managing agent); provided, however, that any management agreement, service contract, or employee contract entered into before the Turnover Meeting shall not be in excess of three (3) years, and shall be terminable by the Association without penalty upon not less than 30 days written notice to the other party given not later than 60 days after the Turnover Meeting; and provided further, that any agreement for management services entered into after the Turnover Meeting on behalf of the Association must be terminable by the Association for cause upon not more than 30 days' notice, must have a reasonable term not exceeding two years, and must be renewable with the consent of the Association and the manager. If a Mortgagee had previously required professional management, the Board of Directors may not terminate professional management and assume self-management unless the decision to do so is approved by at least one hundred percent (100%) of the total voting power of the Association, and approved by Mortgagees holding Mortgages on Units which have at least fifty-one percent (51%) of the voting rights of the Units subject to Mortgagee Mortgages.

3.2.6 Adoption and amendment of reasonable rules and regulations of the Condominium ("Rules and Regulations") pursuant to Section 7.27 hereof.

3.2.7 Maintaining bank accounts on behalf of the Association and designating the signatories required therefor.

3.2.8 Purchasing, leasing or otherwise acquiring, in the name of the Association or its designee, corporate or otherwise, on behalf of the Owners, Units offered for sale or lease or surrendered by their Owners to the Association.

3.2.9 Bidding for and purchasing Units at foreclosure sales (judicial or non-judicial) or other judicial or execution sales, in the name of the Association or its designee, corporate or otherwise, on behalf of all Owners upon the consent or approval of the Owners.

3.2.10 Selling, leasing, mortgaging, voting the votes appurtenant to (other than for the election of directors), or otherwise dealing with Units of the Condominium acquired by the Association or its designee on behalf of all the Owners.

3.2.11 Organizing corporations or limited liability companies to act as designees of the Association in acquiring title to or leasing Units by the Association on behalf of all Owners.

3.2.12 Obtaining and reviewing bonds and insurance, including officers' and directors' liability insurance, for the Association and the Condominium, including the Units, pursuant to the provisions of these Bylaws and in the case of such insurance, reviewing it at least annually.

3.2.13 Making repairs, additions and improvements to, or alterations of, the Condominium and repairs to and restoration of the Condominium in accordance with these Bylaws after damage or destruction by fire or other casualty, or as a result of condemnation or eminent domain proceedings or settlement under the threat thereof.

3.2.14 Making additions and improvements to, or alterations of, the Common Elements; provided, however, that no such project may be undertaken by the Board of

Directors if the total cost will exceed the amount of Twenty-Five Thousand Dollars (\$25,000), unless the Owners have enacted a resolution authorizing the project by a vote of Owners holding at least 75 percent of the voting power of the Association, present in person or by proxy at a meeting of the Owners. This limitation shall not be applicable to repairs or maintenance undertaken pursuant to Section 3.2.1 or to work that is urgently needed for life, safety or structural integrity reasons.

3.2.15 After giving written notice and an opportunity to be heard, levying reasonable fees, late charges, fines and/or interest against the Owners for violations of the Declaration, Bylaws, and/or Rules and Regulations, in addition to exercising any other rights or remedies provided for in the foregoing documents, based on a resolution of the Board of Directors that is delivered to each Unit, mailed to the mailing addresses designated in writing by the Owners, or mailed to the mailing address for each Unit.

3.2.16 Borrowing money on behalf of the Association when required in connection with the operation, care, upkeep, and maintenance of the Common Elements, Parking Units and Association Property; provided, however, that (i) the consent of Owners holding at least 75 percent of the voting power of the Association, obtained at a meeting duly called and held for such purpose in accordance with the provisions of these Bylaws, shall be required for the borrowing of any sum in excess of an amount or amounts, aggregated for the calendar year in question, exceeding 15 percent of the estimated budget of the Association for that calendar year to cover the operation, care, upkeep and maintenance of the Common Elements, Parking Units and Association Property, and (ii) no lien to secure repayment of any sum borrowed may be created on any Unit or its appurtenant interest in the Common Elements without the consent of the Owner of such Unit. If any sum borrowed by the Board of Directors on behalf of the Association pursuant to the authority contained in this Section 3.2.16 is not repaid by the Association, an Owner who pays to the creditor such proportion thereof equal to his or her interest in the Common Elements shall be entitled to obtain from the creditor a release of any judgment or other lien that said creditor shall have filed or shall have the right to file against such Owner's Unit.

3.2.17 Adjusting and settling claims under insurance policies and executing and delivering releases on settlement of such claims on behalf of all Owners, all holders of Mortgages or other liens on the Units, and all Owners of any other interest in the Condominium.

3.2.18 Filing all appropriate income tax returns.

3.2.19 Filing of the Annual Report described in Section 100.260 of the Act with the Real Estate Agency pursuant to Section 100.250 of the Act.

3.2.20 Charging and collecting a fee in connection with an Owner or occupant moving into or out of a Primary Unit.

3.2.21 Charging and collecting a fee in connection with moving in to or out of a Primary Unit.

3.2.22 Enforcement by legal means of the provisions of the Act, the Declaration, these Bylaws and any Rules and Regulations adopted hereunder. Nothing in these

Bylaws shall be construed as requiring the Association to take any specific action to enforce violations.

3.2.23 In conjunction with preparation and updating of the reserve study, establish, periodically update, and implement a 30-year "Maintenance Plan" that identifies those components of the Common Elements, Association Property and Parking Units requiring periodic maintenance, including a maintenance manual defining how and when such maintenance should be performed, setting forth the estimated cost of such maintenance and including information about warranties. The Maintenance Plan shall comply with ORS 100.175 and shall provide for not less than annual inspections of the Property for evidence of water intrusion or other needed repairs by a knowledgeable independent party or the property manager for the Association, and the Board shall reasonably address any matters revealed by the inspection. The Maintenance Plan shall be appropriate for the size and complexity of the Common Elements and Association Property. For a period of ten (10) years following recording of the Declaration, Declarant shall be notified prior to the inspections, shall have a right for Declarant or its employees or contractors to be present during the inspections and have a right to receive a copy of the inspection reports promptly upon request. The operating and reserve budgets of the Association shall take into account the costs of complying with the Maintenance Plan. Changes or updates to the Maintenance Plan should be based upon the advice of competent experts or consultants.

3.2.24 Investing the funds of the Association in accordance with an investment policy adopted and modified from time to time by the Board of Directors.

3.3 Limitation. The powers of the Board of Directors enumerated in these Bylaws shall be limited in that the Board of Directors shall have no authority to (i) acquire and pay for out of the maintenance fund of the Association any structural alterations or capital improvements of, or capital additions to, the Common Elements (other than for purposes of repairing, replacing or restoring portions of the Common Elements, subject to all the provisions of these Bylaws) requiring an expenditure in excess of an amount or amounts, aggregated for the calendar year in question, exceeding 10 percent of the estimated total budget of the Association for such calendar year, or (ii) enter into service agreements having a term in excess of three years, except agreements specifically authorized in these Bylaws or the Declaration, without, in each case, the prior approval of Owners holding at least 75 percent of the voting power of the Association.

3.4 Organizational Meeting. Within 30 days following the annual meeting of the Association or following any meeting at which an election of Directors has been held, the Board of Directors shall hold an organizational meeting at such place and time as shall have been fixed by the Directors at the meeting at which the election was held.

3.5 Regular and Special Meetings. Regular meetings of the Board of Directors may be held at such time and place as shall be determined, from time to time, by a majority of the Directors. Special meetings of the Board of Directors may be called by the Chairperson and must be called by the Secretary at the written request of at least two Directors. Notice of any special meeting shall be given to each Director and the Declarant or its successors and assigns, personally or by mail, telephone or facsimile at least two days prior to the day named for such meeting, and shall state the time, place and purpose of such meeting, including whether the Board intends to

vote to meet in executive session and the general nature of the action to be considered in executive session. All meetings of the Board of Directors shall be open to the Owners and Declarant or its successors and assigns except that the following matters and any other matters permitted by the Act may be considered in executive session: (a) consulting with legal counsel regarding the rights and duties of the Association in connection with existing or potential litigation, or criminal matters; (b) dealing with personnel matters, including salary negotiations and discipline; (c) negotiation of contracts with third parties; and (d) collection of unpaid assessments pursuant to the Act. Except in the event of an emergency, the Board of Directors shall vote in an open meeting on whether to meet in executive session. If the Board of Directors votes to meet in executive session, the Chairperson shall announce the general nature of the action being considered and when and under what circumstances the deliberations can be disclosed to the Owners. The statement, motion, or decision to meet in executive session must be included in the minutes of the meeting. A contract or action considered in executive session does not become effective unless the Board, following the executive session, reconvenes in an open meeting and votes on the contract or action, which must be reasonably identified in the open meeting and included in the minutes. Such meetings may be conducted by telephonic communication or by other means authorized under ORS 100.420(2), except that if a majority of the Primary Units are principal residences of the occupants, then: (i) for other than emergency meetings, notice of each meeting of the Board of Directors shall be posted at a place or places on the Property at least three days prior to the meeting, or notice shall be provided by a method otherwise reasonably calculated to inform the Owners of such meeting; and (ii) only emergency meetings of the Board of Directors may be conducted by telephonic communication or in a manner permitted by the Act. The meeting and notice requirements in ORS 100.420(1) may not be circumvented by chance or social meetings or by any other means, including, without limitation, e-mail communication. For purposes of this Section, "meeting" shall have the definition provided in Section 100.420(5) of the Act. Unless other rules of order are adopted by resolution of the Association or the Board of Directors, all meetings of the Board of Directors shall be conducted according to the latest edition *Robert's Rules of Order* published by Robert's Rules Association.

3.6 Waiver of Notice. Any member of the Board of Directors may at any time waive notice of any meeting of the Board of Directors in writing and such waiver shall be deemed equivalent to the giving of such notice. Attendance by a member of the Board of Directors at any meeting of the Board of Directors shall constitute a waiver of notice of the time and place thereof, except where a Director attends the meeting for the sole purpose of objecting to the transaction of any business because the meeting is not lawfully called or convened. If all the members of the Board of Directors are present at any meeting of the Board of Directors, however, no notice to Directors shall be required and any business may be transacted at such meeting.

3.7 Quorum. At all meetings of the Board of Directors, a majority of the members thereof shall constitute a quorum for the transaction of business, and the votes of a majority of the members of the Board of Directors present at a meeting at which a quorum is present shall constitute the act of the Board of Directors; provided, however, that the approval of the director elected by the Owners of the Retail Units shall be necessary for the Board to take any action which would eliminate or impair the rights and privileges granted to the Owners of the Retail Units. If at any meeting of the Board of Directors there shall be less than a quorum present, a majority of those present may adjourn the meeting from time to time until a quorum is present. At any such adjourned meeting at which a quorum is present, any business that might have been transacted at the meeting originally called may be transacted without further notice.

3.8 Removal. At any regular or special meeting of the Owners, any one or more of the members of the Board of Directors elected by the Residential Owners may be removed with or without cause, but only by approval of at least a majority of the Residential Owners, notwithstanding the quorum provisions of Section 2.11, and a successor may then and there or thereafter be elected to fill the vacancy thus created. The notice of any such meeting shall state that such removal is to be considered, and any Director whose removal has been proposed shall be given an opportunity to be heard at the meeting. The Director elected by the Retail Owners may be removed with or without cause at a meeting called by the Retail Owners by the vote of the Retail Owners, notwithstanding any quorum requirement, and a successor may then and there or promptly thereafter be elected to fill the vacancy thus created by the vote of the Retail Owners. The notice of any such meeting shall state that such removal is to be considered, and any Director elected by the Retail Owners whose removal has been proposed shall be given an opportunity to be heard at the meeting.

3.9 Resignation. Any Director may resign at any time by sending a written notice of such resignation to the office of the Association, addressed to the Secretary. Unless otherwise specified therein, such resignation shall take effect upon receipt thereof by the Secretary.

3.10 Vacancies. Vacancies on the Board of Directors caused by any reason other than the removal of a member pursuant to Section 3.8 shall, in the case of a vacancy relating to a Director elected by the Residential Owners, be filled by vote of a majority of the remaining Directors at a special meeting of the Board of Directors held for that purpose promptly after the occurrence of any such vacancy, even though the Directors present at such meeting may constitute less than a quorum. Any vacancy relating to a Director elected by the Retail Owners shall be filled by the vote of a majority of the Retail Owners at a special meeting of the Retail Owners held promptly after the occurrence of the vacancy. Each person so elected or appointed shall be a member of the Board of Directors for the remainder of the term of the member whose position was vacated and until a successor shall be elected by the vote of the Retail Owners at the next annual meeting of the Owners.

3.11 Compensation. No Director shall receive any compensation from the Association for acting in such capacity, but shall be reimbursed for his reasonable out-of-pocket expenses.

3.12 Liability and Indemnification of Directors, Officers, Manager or Managing Agent. To the fullest extent authorized by law and the Articles, the personal liability of each Director to the Association or its Owners for monetary damages for conduct as a Director shall be eliminated. Each Director and officer and the manager or managing agent, if any, shall be indemnified and held harmless by the Association, to the fullest extent permitted by law, from and against all expenses and liabilities, including attorneys' fees, reasonably incurred or imposed upon such person in connection with any proceeding to which he may be a party, or in which he may become involved, by reason of being or having been a Director, officer, manager or managing agent and shall be indemnified upon any reasonable settlement thereof. The foregoing rights of indemnification shall be in addition to and not exclusive of any and all other rights conferred on such persons under any agreement, vote of the Owners or otherwise.

3.13 Insurance. The Board of Directors shall comply with the insurance requirements contained in Article 9 of these Bylaws. In addition, the Board of Directors, in its

discretion, may obtain such other insurance as it deems necessary to protect the interests of the Association, the Board of Directors or the Owners.

3.14 Special Committees. The Board of Directors by resolution may designate one or more special committees, each committee to consist of three or more Owners that, to the extent provided in such resolution, shall have and may exercise the powers set forth in such resolution. Such special committee or committees shall have such name or names as may be determined from time to time by the Board of Directors. Such special committee shall keep regular minutes of their proceedings and report the same to the Board of Directors when required. The members of such special committee or committees designated shall be appointed by the Board of Directors or the Chairperson. The Board of Directors or the Chairperson may appoint Owners to fill vacancies on each of any special committees occasioned by death, resignation, removal, or inability to act for any extended period of time.

4. OFFICERS.

4.1 Designation. The principal officers of the Association shall be the Chairperson, the Secretary and a treasurer (the "Treasurer"), all of whom shall be elected by the Board of Directors. The Board of Directors may appoint a vice Chairperson (the "Vice Chairperson"), an assistant treasurer (an "Assistant Treasurer"), an assistant secretary (an "Assistant Secretary") and such other officers as in its judgment may be desirable. None of the officers need be Owners until the Board of Directors is elected by the Owners at the Turnover Meeting. Thereafter, all officers shall be Owners (or officers, directors, shareholders, partners, employees or beneficiaries, or members of the respective families, of Units owned by corporations, partnerships, fiduciaries or Mortgagees).

4.2 Election. The officers of the Association shall be elected annually by the Board of Directors at the organizational meeting of each new Board of Directors and shall hold office at the pleasure of the Board of Directors and until their successors are elected and qualified. If any office shall become vacant, the Board of Directors shall elect a successor to fill the unexpired term at any regular meeting of the Board of Directors, or at any special meeting of the Board of Directors called for such purpose.

4.3 Removal. Upon the affirmative vote of a majority of the Board of Directors, any officer may be removed, either with or without cause, and his successor may be elected at any regular meeting of the Board of Directors or at any special meeting of the Board of Directors called for such purpose.

4.4 Chairperson. The Chairperson shall be the chief executive officer of the Association. The Chairperson shall preside at all meetings of the Owners and of the Board of Directors. The Chairperson shall have all of the general powers and duties that are usually incident to the office of the chief executive officer of an association, including, but not limited to, the power to appoint committees from among the Owners from time to time as the Chairperson may in his or her discretion decide are appropriate to assist in the conduct of the affairs of the Association.

4.5 Vice Chairperson. The Vice Chairperson shall take the place of the Chairperson and perform his or her duties whenever the Chairperson shall be absent or unable to act. If neither the Chairperson nor the Vice Chairperson is able to act, the Board of Directors

shall appoint some other member of the Board of Directors to act in the place of the Chairperson on an interim basis. The Vice Chairperson shall also perform such other duties as shall from time to time be prescribed by the Board of Directors or by the Chairperson.

4.6 Secretary. The Secretary shall keep the minutes of all proceedings of the Board of Directors and the minutes of all meetings of the Association. He or she shall attend to the giving and serving of all notices to the Owners and Directors and other notices required by law. He shall keep the records of the Association, except for those of the Treasurer, and shall perform all other duties incident to the office of Secretary of an association and as may be required by the Directors or the Chairperson. In addition, the Secretary shall act as Vice Chairperson, taking the place of the Vice Chairperson and performing his or her duties whenever the Vice Chairperson is absent or unable to act, unless the Directors have appointed another Vice Chairperson.

4.7 Treasurer. The Treasurer shall be responsible for Association funds and securities and shall be responsible for keeping full and accurate financial records and books of account showing all receipts and disbursements necessary for the preparation of all required financial data. He or she shall be responsible for the deposit of all funds and other valuable effects in such depositories as may from time to time be designated by the Board of Directors, and he shall disburse funds of the Association upon properly authorized vouchers. He or she shall in general perform all other duties incident to the office of Treasurer of an association and such other duties as may be assigned to him by the Board of Directors.

4.8 Execution of Instruments. All agreements, contracts, deeds, leases and other instruments of the Association, shall be executed by such person or persons as may be designated by general or special resolution of the Board of Directors, including the execution of checks of up to Twenty-Five Thousand Dollars (\$25,000) by the professional property management company for the Condominium for budgeted operating and reserve expenses, and, in the absence of any general or special resolution applicable to any such instrument, then such instrument shall be signed by the Chairperson. All checks of Twenty-Five Thousand Dollars (\$25,000) or more shall be signed by the Treasurer, or in his absence or disability, by the Chairperson or any duly elected Assistant Treasurer.

4.9 Compensation of Officers. No officer who is a member of the Board of Directors, other than the Secretary and Treasurer, shall receive any compensation from the Association for acting as an officer, unless such compensation is authorized by a resolution duly adopted by the Owners. The Board of Directors may fix any reasonable compensation to be paid to the Secretary, Treasurer and any officers who are not also Directors.

5. BUDGET, EXPENSES AND ASSESSMENTS.

5.1 Budget. The Board of Directors shall from time to time, at least annually, prepare a budget for the Association, estimate the common expenses expected to be incurred, less any previous overassessment, and assess the common expenses to each Owner in the manner set forth in the Declaration. The budget shall provide for an adequate reserve fund for maintenance, repairs and replacement of those Common Elements that must be maintained, repaired or replaced on a periodic basis by the Association in accordance with Section 5.2 of these Bylaws, and the budget shall also divide the common expenses into Retail Expenses and

Residential Expenses in accordance with Section 7.1 of the Declaration. The Board of Directors shall advise each Owner in writing of the amount of common expenses payable by him or her, and furnish a summary of each budget and amended budget on which such common expenses are based to all Owners and, if requested, to their Mortgagees, within 30 days after adoption of the budget. Failure to deliver a summary of any budget or amended budget to each Owner shall not affect the liability of any Owner for any such assessment. Nothing herein contained shall be construed as restricting the right of the Board of Directors to, at any time, in their sole discretion, levy any additional assessment in the event that the budget originally adopted shall appear to be insufficient to pay costs and expenses of operation and management of the Condominium, or in the event of emergencies. Any budget for the Association prepared by Declarant or during the period of Declarant's administrative control of the Association pursuant to Section 20 of the Declaration shall be based on Declarant's reserve study, but such projection may vary substantially from the actual requirements of the Association for such period. **The reserve study assumes that the Board conducts normal, routine maintenance for the elements reserved for and that the Board is required to perform pursuant to this Declaration, the Bylaws, the Maintenance Plan and the Act. If the Board fails to perform required maintenance, the reserve fund may be inadequate at the time of the required replacement for one or more elements included in the reserve study.** After the Turnover Meeting, the Board of Directors shall be responsible, in its sole discretion, for preparation of the budget of the Association and shall not rely upon prior budgets or projections prepared by Declarant. The budget shall take into account the requirements of the Maintenance Plan adopted pursuant to Section 3.2.23 above.

5.2 Reserve Fund for Replacing Common Elements. Declarant shall conduct a reserve study as required by the Act and shall establish in the name of the Association a reserve fund for replacement of Common Elements that will normally require replacement in more than three (3) and fewer than 30 years, exterior painting of painted Common Elements, if any, and for significant future maintenance items as required by the Maintenance Plan. The common expenses of the Condominium shall be calculated on the basis of expected replacement costs and life expectancy of the items comprising the Common Elements that will normally require replacement in more than three and fewer than 30 years, exterior painting of painted Common Elements, if any, and for significant future maintenance items as required by the Maintenance Plan such that the reserve fund is reasonably expected to provide sufficient funds for replacement of such Common Elements. Declarant in establishing the reserve fund shall obtain and rely on a reserve study from a professional property manager or reserve study provider, but such projection may vary substantially from the actual requirements of the Association. Declarant may elect to defer payment of the assessments for the reserve fund with respect to a Unit until the time of conveyance of the Unit; provided that Declarant may defer payment of such reserve assessments beyond the date of the Turnover Meeting, or, if no Turnover Meeting is held, the date the Owners assume administrative control of the Association. The Board of Directors shall administer the reserve fund and shall adjust at regular intervals, but no less than annually, the amount of the periodic payments into it to reflect changes in current replacement costs over time. The Board of Directors shall annually conduct a reserve study or review and update an existing reserve study of the Common Elements to determine reserve account requirements. The Board of Directors shall, within 30 days after conducting the reserve study, provide to each Owner and Declarant, its successors or assigns a written summary of the reserve study and any revisions to the Maintenance Plan as a result of the reserve study. The reserve study shall include all information required by the Act, including, without limitation, the Maintenance Plan.

Following the second year after the Turnover Meeting, the Association may by an affirmative vote of at least 75 percent of the Owners elect to reduce or increase future assessments for the reserve funds. In addition the Board of Directors' authority to do so, after the Turnover Meeting, the Association may, on an annual basis by unanimous vote of the Owners, elect not to fund the reserve account. Any funds established for any of the purposes mentioned in this Section shall be deemed to be a reserve fund notwithstanding that it may not be so designated by the Board of Directors. The amount of the reserve fund shall constitute an asset of the Association and shall not be distributed to any Owner except on termination of the Condominium and the Association. The reserve fund is to be used only for replacement of the Common Elements that will normally require replacement in more than three (3) and fewer than 30 years, for the painting of exterior painted surfaces, if any, and for significant future maintenance items as required by the Maintenance Plan and is to be kept separate from the assessments described in Section 5.4 of the Bylaws. After the Turnover Meeting, however, the Board of Directors may borrow amounts from the reserve fund to meet high seasonal demands on funds obtained from regular assessments or to meet other unexpected increases in expenses that will later be paid from special or regular assessments, if the Board of Directors has adopted a resolution, which may be an annual continuing resolution, authorizing the borrowing of funds and, prior to adopting such a resolution, has provided advance notice of the pending resolution to all Owners and, for 10 years after recording of the Declaration, to Declarant and its successors and assigns. Not later than the adoption of the budget for the following year, the Board shall adopt by resolution a repayment plan providing for repayment of the borrowed funds within a reasonable period. Repayment of such amounts borrowed from the reserve fund shall include any interest that would otherwise have been earned on such amounts. Assessments under this Section 5.2 shall be allocated between Retail Unit and Residential Units described in Section 7.1 of the Declaration.

5.3 Determination of Common Expenses. Common expenses shall include:

5.3.1 Expenses of administration.

5.3.2 Cost of insurance or bonds obtained in accordance with these

Bylaws.

5.3.3 A general operating reserve, sufficient to pay the amount of the deductible on any insurance policy held by the Association under Section 9.1.1.

5.3.4 Reserve for replacements and deferred maintenance and the cost of the reserve study, or its review and update.

5.3.5 Any deficit in common expenses for any prior period, and any accrued interest or late charges thereon.

5.3.6 Utilities for the Common Elements and other utilities not separately metered or charged.

5.3.7 Services of any person or firm to act on behalf of the Owners in connection with any other matter where the respective interests of the Owners are deemed by the Board of Directors to be similar and nonadverse to each other.

5.3.8 Professional management services, concierge services, landscaping, snow removal, waste removal (subject to the provisions of the Declaration relating thereto), painting, cleaning, outside window washing and inspection, maintenance, repair and replacement of the exterior of the structures within the Condominium and inspection, maintenance, decorating, repair and replacement of the Common Elements and Parking Units by the Association (but not including glass of windows opening on to a Primary Unit, interior surfaces of Units, interior doors that provide the means of ingress and egress to and from a Primary Unit, which the respective Owners of such Primary Units shall paint, clean (except for outside window surfaces), decorate, maintain, and repair) and such furnishings and equipment for the Common Elements, Parking Units and Association Property as the Board of Directors shall determine are necessary and proper, which the Board of Directors shall have the exclusive right and duty to acquire for the Common Elements, Parking Units and Association Property.

5.3.9 Any other materials, supplies, furniture, labor, services, maintenance, repairs, structural alterations or assessments that the Board of Directors is required to secure or pay for, pursuant to the terms of the Declaration or these Bylaws or that in its opinion shall be necessary or proper for the maintenance and operation of the Condominium as a first-class Condominium or for the enforcement of these restrictions, and that the Board of Directors determines should be assessed to the Owners under Section 5.4.

5.3.10 Paving, resurfacing, or restriping of Parking Units.

5.3.11 The discharge of any mechanic's lien or other encumbrance levied against the entire Condominium or against the Common Elements or Association Property, rather than merely against the interests therein of particular Owners. Where one or more Owners are responsible for the existence of such lien, they shall be jointly and severally liable for the cost of discharging it and any costs incurred by the Board of Directors by reason of such lien or liens shall be specifically assessed to the responsible Owners.

5.3.12 Inspection, maintenance and repair of any Unit, Association Property or Common Element if the Board of Directors determines that such inspection, maintenance or repair is necessary to protect the Common Elements, Association Property or any other portion of the Property, and the Owner of such Unit (or the Owner responsible for maintenance of such Common Element, as applicable) has failed or refused to perform such maintenance or repair within a reasonable time after written notice of the necessity of such maintenance or repair delivered by the Board of Directors to such Owner, provided that the Board of Directors shall levy a special assessment against such Owner for the cost of such maintenance or repair.

5.3.13 Any other items properly chargeable as an expense of the Association, including, without limitation, those items described in the exhibits to the Declaration.

5.4 Assessment of Common Expenses. All Owners shall be obliged to pay on a monthly basis in advance common expenses assessed to them by the Board of Directors on behalf of the Association pursuant to these Bylaws and the Declaration, including amounts applicable to the reserve fund described in Section 5.2 of these Bylaws; provided, however, that such reserve assessments may be collected on a monthly, quarterly, or biannual basis, and at least annually, and may be assessed prospectively or in arrears. Assessments for Retail and

Residential Expenses shall be allocated in accordance with Section 7.1 of the Declaration. Assessments may not be waived due to limited use or nonuse of Common Elements. Declarant shall be assessed as the Owner of any unsold Unit, but such assessment shall be prorated to the date of sale of the Unit. Assessments shall commence in accordance with Section 7.1 of the Declaration. At the time of closing of the initial sale of each Primary Unit, the purchaser shall make the contribution described in Section 5.5.3 to the working capital fund. The Board of Directors, on behalf of the Association, shall assess the common expenses against the Owners from time to time, and at least annually, and shall take prompt action to collect from an Owner any common expense due that remains unpaid by him or her for more than 30 days from the due date for its payment (except as provided above for the Declarant).

5.5 Special Assessments.

5.5.1 Capital Improvements. In the case of any duly authorized capital improvement to the Common Elements, the Board of Directors may by resolution establish separate assessments for the same, which may be treated as capital contributions by the Owners, and the proceeds of which shall be used only for the special capital improvements described in the resolution.

5.5.2 Other Reserve Trust Funds. The Board of Directors may also build up and maintain a reasonable reserve for contingencies and replacements not covered by Section 5.2 of these Bylaws. Extraordinary expenditures not originally included in the annual estimate that may become necessary during the year may be charged against such reserve. If the estimated cash requirement proves inadequate for any reason, including nonpayment of any Owner's assessment, the Board of Directors may at any time levy a further assessment, which shall be assessed to the Owners according to the allocations set forth in Section 7.1 of the Declaration. The Board of Directors shall serve notice of such further assessment on all Owners by a statement in writing giving the amount and reasons therefor, and such further assessment shall become effective with the first monthly assessment of common expenses that is due more than 30 days after the delivery or mailing of such notice of further assessment. Any reserve fund established by Declarant shall be based upon Declarant's reserve study and Maintenance Plan of the applicable reserve requirements of the Association, but such projection may vary substantially from the actual requirements of the Association.

5.5.3 Working Capital Fund. Declarant shall establish in the name of the Association a working capital fund for the Association. Amounts paid into this fund shall not be considered advance payments of the monthly assessments for common expenses described in Section 5.4. At the time of closing of the initial sale of each Primary Unit, the purchaser shall make an initial contribution to the working capital fund equal to two months of Association assessments for such Unit, but, in any event, not less than the amount that may have been contributed to the working capital fund on behalf of such Unit (or Units) by Declarant under this Section 5.5.3. At or prior to the Turnover Meeting, Declarant shall make a contribution to the working capital fund equal to two months of Association assessments for all Primary Units then existing but not yet conveyed to persons other than Declarant; provided, however, that the contribution by the initial purchaser of a Primary Unit described in the preceding sentence shall be paid to Declarant at the closing of such purchase in reimbursement of contributions made to the working capital fund by Declarant. At or prior to the Turnover Meeting, Declarant shall transfer the amount of the working capital reserve fund to the Association for deposit in a

segregated fund and administration in accordance with Section 5.5.2. During the period of administrative control described in Section 21 of the Declaration, Declarant shall not use any funds contained in the working capital fund to defray Declarant's expenses, contributions to reserves, or construction costs, or to compensate for any deficits in the operating budget of the Condominium.

5.6 Violation by Owners; Remedies. The violation of any Rule or Regulation or other determination duly adopted by the Board of Directors, or the breach of any covenant or provision contained in the Declaration or these Bylaws, shall give the Association the right: (i) to enter upon that part of the Condominium where such violation or breach exists and summarily abate and remove, at the expense of the defaulting Owner, any structure, thing or condition that may exist thereon contrary to the intent and meaning of the provisions so violated, and the Association, or its agents, shall not thereby be deemed guilty in any manner of trespass; provided, however, that the Association must institute legal proceedings before any item of construction may be altered or demolished in remedying such violation, and (ii) to enjoin, abate or remedy by appropriate legal proceedings the continuance of any breach. Any Owner aggrieved by such a violation shall also have the right, on behalf of the Association, to enjoin, abate, or remedy by appropriate legal proceedings any such violation and to recover its expenses in accordance with Section 11.1. All expenses of the Association in connection with such violation and such action or proceedings (including any action or proceeding brought on behalf of the Association), including engineering, architectural and other professional fees and costs, court costs and attorneys' fees and any other fees and expenses (including fees, fines, late charges and interest imposed pursuant to these Bylaws), and all damages, liquidated or otherwise, together with interest thereon at the rate provided in Section 7.3 of the Declaration until the amount outstanding is paid, shall be charged to and assessed against such defaulting Owner and shall be added to and deemed part of his respective share of the common expenses. The Association shall have a lien for all of the same upon the Units of such defaulting Owner and upon all of his or her additions and improvements thereto and upon all of his or her personal property located in such Units or elsewhere in the Condominium. Any and all of such rights and remedies may be exercised at any time and from time to time, cumulatively or otherwise, by the Board of Directors. Any violations by an Owner of the Declaration, these Bylaws or any Rules and Regulations that are deemed by the Board of Directors to be a hazard to public health or safety may be corrected immediately as an emergency matter by the Association, and the cost thereof shall be charged to the offending Owner as a specific item, which shall be a lien against the offending Owner's Unit or Units with the same force and effect as if the charge were a part of the normal common expenses attributable to such Unit or Units.

5.7 Liability of Owners. An Owner shall be liable for the expenses of any maintenance, repair or replacement rendered necessary by his act, neglect or carelessness or by that of any member of his family, or his or their pets, guests, employees, servants, invitees, agents or lessees, but only to the extent that such expense is not met by the proceeds of insurance carried by the Association. Such liability shall include any increase in insurance rates occasioned by use, misuse, occupancy or abandonment of any Unit or its appurtenances. Nothing in these Bylaws, however, shall be construed to modify any waiver by insurance companies of rights of subrogation. The expense of any such maintenance, repair or replacement shall be charged to the responsible Owner as a specific item, which shall be a lien against such Owner's Unit or Units with the same force and effect as if the charge were a part of the normal common expenses attributable to such Owner's Unit or Units.

5.8 No Waiver. The failure of the Association or of an Owner to enforce any right, provision, covenant or condition that may be granted by any of the provisions of the Declaration, these Bylaws or any Rules or Regulations shall not constitute a waiver of the right of the Association or an Owner to enforce such right, provision, covenant or condition in the future.

5.9 Receiver. From the time of commencement of an action by the Association to foreclose a lien for nonpayment of delinquent assessments regarding a Unit that is not occupied by the Owner thereof, the Association shall be entitled to the appointment of a receiver to collect from the lessee thereof the rent for the Unit as and when due. If the rental is not paid, the receiver may obtain possession of the Unit, refurbish it for rental up to a reasonable standard for rental units in this type of Condominium, rent the Unit or permit its rental to others, and apply the rents first to the cost of the receivership and attorneys' fees thereof, then to the cost of refurbishing the Unit, then to applicable charges, then to costs, fees, and charges of the foreclosure action, and then to the payment of the delinquent assessments. Only a receiver may take possession and collect rents under this Section, and a receiver shall not be appointed less than 90 days after the delinquency. The exercise by the Association of the foregoing rights shall not affect the priority of preexisting liens on the Unit.

6. RECORDS AND AUDITS.

6.1 General Records. The Board of Directors and the managing agent or manager, if any, shall keep detailed records of the actions of the Board of Directors and the managing agent or manager, minutes of the meetings of the Board of Directors, minutes of the meetings of the Association and contemporaneous written documentation of the Association's inspection, operation, care, upkeep, repair, replacement and maintenance of the Common Elements, Parking Units and Association Property. The Board of Directors shall maintain a list of Owners entitled to vote at meetings of the Association and a list of all Mortgagees of Units. The Association shall maintain within the State of Oregon a copy, suitable for duplication, of: (i) the Declaration, these Bylaws, the Rules and Regulations, the recorded plat(s) and any amendments or supplements thereto; (ii) the most recent annual financial statement of the Association described in Section 6.5 hereof; (iii) the current operating budget, reserve study and Maintenance Plan of the Association; and (iv) all documents, information and records delivered to the Association at the Turnover Meeting. Such documents shall be available for inspection within the State of Oregon and upon written request, available for duplication by the Declarant or its successors and assigns, Owners, Mortgagees of Units, insurers and guarantors of such Mortgages, and prospective purchasers of Units during normal business hours. The Board of Directors shall retain the documents required by 100.480(1) for the time period required by such statute. Records kept by or on behalf of the Association may be withheld from examination as permitted by the Act.

6.2 Records of Receipts and Expenditures. The Board of Directors or its designee shall keep detailed, accurate records in chronological order of the receipts and expenditures affecting the Common Elements, itemizing the maintenance and repair expenses of the Common Elements and any other expenses incurred. Such records and the vouchers authorizing the payments shall be available for examination by the Owners, Mortgagees of Units, and insurers and guarantors of such Mortgages during normal business hours.

6.3 Assessment Roll. The assessment roll shall be maintained in a set of accounting books in which there shall be an account for each Unit. Such account shall designate the name and address of the Owner or Owners, the amount of each assessment against the Owners, the dates and amounts in which the assessment comes due, the amounts paid upon the account and the balance due on the assessments.

6.4 Payment of Vouchers. The Treasurer shall pay all vouchers up to Five Thousand Dollars (\$5,000) signed by the Chairperson, managing agent, manager or other person authorized by the Board of Directors. Any voucher in excess of Five Thousand Dollars (\$5,000) shall require the signature of the Chairperson and one other officer of the Association.

6.5 Reports and Audits. An annual audited financial statement of the Association, consisting of at least a balance sheet and income and expense statement for the preceding fiscal year, shall be rendered by the Board of Directors to all Owners, and to all Mortgagees of Primary Units who have requested the same, within 90 days after the end of each fiscal year. At any time any Owner or Mortgagee of a Primary Unit may, at his own expense, cause an audit or inspection to be made of the books and records of the Association. Pursuant to ORS 100.480(6), the Association may elect on an annual basis not to comply with ORS 100.480(4) by an affirmative vote of at least 60% of the Owners, not including the votes of the Declarant with respect to Units owned by the Declarant. Upon written request, any holder, insurer or guarantor of a first Mortgage shall be entitled to a copy of the audited financial statement for the immediately preceding fiscal year at the expense of the Association and shall be made available within 120 days after the end of such fiscal year. In addition, the Board shall not less than annually provide each Owner and the Declarant, its successors and assigns a written report regarding the Association's compliance with the Maintenance Plan.

6.6 Notice of Sale, Mortgage, Rental or Lease. Immediately upon the closing of any sale, Mortgage, rental or lease of any Unit, the Owner shall promptly inform the Secretary or manager of the name and address of the purchaser, Mortgagee, lessee, or tenant.

6.7 Statement of Assessments. Within 10 business days after receipt of a written request from an Owner or Owner's agent for the benefit of a prospective purchaser of such Owner's Unit(s), the Association shall provide a written statement detailing the amount of assessments due from the Owner and unpaid at the time the request was received, including regular and special assessments, fines and other charges, accrued interest, late payment charges; the percentage rate at which interest accrues on assessments not paid when due; and the percentage rate used to calculate the late payment charges or the amount of a fixed charge for late payment. The Association is not required to comply with the foregoing request if the Association has commenced litigation by filing a complaint against the Owner and the litigation is pending when the statement would otherwise be due.

7. OCCUPATION AND USE

7.1 Rental. The Leasing or Renting of a Unit by its Owner shall be governed by the provisions of this Section 7.1. "Leasing or Renting" a Unit means the granting of a right to use or occupy a Unit, for a specified term or indefinite term (with rent reserved on a periodic basis), whether in exchange for the payment of rent (that is, money, property or other goods or services of value) or not; but shall not mean and include joint ownership of a Unit by means of joint tenancy,

tenancy-in-common or other forms of co-ownership. With the exception of a lender in possession of a Unit following a default in a Mortgage, a foreclosure proceeding or any deed or other arrangement in lieu of a foreclosure, no Owner shall be permitted to Lease his Unit for hotel or transient purposes, which shall be defined as Renting for any period less than 30 days.

7.1.1 No Partial Leases. No Owner of a Residential, Parking or Storage Unit may Lease less than the entire Unit, except for a Residential Unit when the Owner remains in occupancy of at least a portion of his or her Unit.

7.1.2 Written Leases. All Leasing, Rental or other occupancy agreements shall be in writing and be subject to this Declaration and the Bylaws (with a default by the tenant or occupant in complying with this Declaration and/or Bylaws constituting a default under the Lease, Rental or occupancy agreements).

7.1.3 Payments by Tenant or Lessee to Association. If a Residential Unit is Rented by its Owner, the Board may collect, and the tenant, lessee or occupant shall pay over to the Board, any amounts due to the Association hereunder for such Residential Unit, plus interest and costs if the same are in default over 30 days. The renter, lessee or occupant shall not have the right to question payment over to the Board. Such payment will discharge the lessee's, renter's or occupant's duty of payment to the Owner for rent, to the extent such payment is made to the Association, but will not discharge the liability of the Owner and the Residential Unit under this Declaration for assessments and charges, or operate as an approval of the lease or occupancy agreement. The Board shall not exercise this power where a receiver has been appointed with respect to the Unit or its Owner, nor in derogation of any right which a Mortgagee of such Unit may have with respect to such rents.

7.1.4 Identification of Tenants. Each Owner electing to rent or grant occupancy of his or her Unit shall, within 30 days after the rental or occupancy of such Unit, submit to the Board in writing the identity of and contact information for such tenant or occupant

7.1.5 Limitation on Number of Units. At no time shall more than 30 percent of Primary Units be rented or occupied by non-Owner occupants. In order to insure that the foregoing limitation is not exceeded, Owners who intend to rent or grant occupancy rights to their Residential Units shall provide 30 days written notice to the Board of their intentions. Each such Owner may proceed to rent or grant occupancy to non-Owner occupants for his or her Residential Unit unless such Owner is provided written notice of the Board's refusal to allow such rental or non-Owner occupancy because such rental or non-Owner occupancy would exceed the limitation of the foregoing sentence. In the event of such Board refusal, the requesting Owner shall not rent or grant non-occupancy to any person until the Board notifies him or her that such rental or occupancy would not violate the limitation on non-Owner occupied Primary Units. The Board shall maintain a list of Owners who requested and were denied the ability to rent or grant non-Owner occupancy of their Residential Units, on a first-come, first-served basis and shall promptly notify each Owner on such list as it becomes permissible to rent or grant non-Owner occupancy of such Owner's Residential Unit. The foregoing limitations shall not apply to Rental of Retail Units.

7.1.6 No Other Restrictions. Other than as stated in this Section 7.1, there is no restriction on the right of any Owner to Lease or otherwise Rent his Unit.

7.1.7 Declarant's Activities. The restrictions contained in this Section 7.1 shall not apply to the Leasing or Renting of Units owned by the Declarant.

7.2 Residential Use. Except as expressly permitted in these Bylaws or the Declaration, or as otherwise permitted by Board approval (with such conditions as the Board may establish), each Primary Unit (other than the Retail Unit) shall be occupied and used only as a private residence and for no other purpose. Without the prior consent of the Board of Directors, no more than four persons may live in a Primary Unit on a permanent basis. Nothing contained in the Declaration or Bylaws shall preclude an Owner from having a "home office" from which the Owner conducts some of his or her business affairs, provided (a) the average number of daily trips attributable to the Residential Unit does not exceed six, (b) the number of nonresidential occupants such as employees using the Residential Unit does not exceed two, (c) there are no signs visible outside of the Residential Unit, and (d) the home office use does not cause any infiltration of noise, radiation, vibration, fumes or the like into other Residential Units to any degree that would constitute an unreasonable impediment to the residential use of other Units. Residential Units may not be used exclusively for office use even if the use would comply with the limitations stated above for home offices. Units of the Condominium may be used for operating the Association and for management of the Condominium. Timesharing of Units is prohibited. Except as permitted by the foregoing, no industry, business, trade, occupation or profession of any kind shall be conducted, maintained or permitted in any Unit (other than as set forth in Section 7.3). Nothing contained in this Section 7.2 shall prevent the Declarant or Declarant's successors and assigns from completing the Units and the building they are in, maintaining Units as models for display purposes, and otherwise maintaining construction or sales offices displays and signs.

7.3 Commercial Use. The Retail Units may be used for commercial purposes, including, without limitation, restaurant use, but only if the commercial use of such Unit (i) is conducted such that daily business hours commence no earlier than 6:00 a.m. and end no later than 12:00 a.m., unless, in connection with special occasions, the Board of Directors approves in writing other hours of business for a specified date or dates, (ii) does not cause objectionable noise to emanate out of or arise from such Units, (iii) does not produce objectionable odors, and (iv) does not involve the storage of material amounts of highly combustible materials or other materials that would pose an unreasonable threat to the Condominium or well-being of the Owners. For purposes of construing the foregoing provisions, the term "objectionable noise" shall mean, without limitation and for the purpose of illustration, persistent loud noises made by (i) machinery or equipment, (ii) a gathering of disorderly persons, or (iii) music that can be heard or felt outside the Unit in which such music is played, and the term "objectionable odors" shall mean, without limitation and for the purpose of illustration, strong or unpleasant odors such as odors produced by (i) gas-powered or diesel-powered machinery or equipment, (ii) refuse or garbage, (iii) brewed or fermented liquids (other than coffee or similar beverages), or (iv) any number of chemicals or solvents. "Objectionable odors" shall not include cooking and food smells associated with restaurant use of the Retail Units, provided, however, that a restaurant user shall use reasonable efforts to mitigate odors from its use that would otherwise be offensive to a reasonable person, such as, for example, rotting food waste. The word "objectionable" shall be construed in every instance in accordance with the sensibilities of an ordinary and reasonable person residing in attached condominiums with associated restaurant use in the Condominium in an urban environment. The Owner of each Retail Unit shall have the sole authority, in its sole discretion, to determine whether the proposed commercial use is permitted under this Section. The

Owner of each Retail Unit may assign this authority to the Board of Directors. In the event of such an assignment, the determination of the Board of Directors with respect to the restrictions imposed by this Section 7.3 shall be final and conclusive, unless a special meeting for the purpose of reviewing the propriety of such decision is called pursuant to Section 2.6 and at that meeting, providing a quorum is certified, at least 75% of Owners present in person or by proxy vote to overturn the decision of the Board of Directors, in which case the written determination of the Owners at such meeting shall be final and conclusive. Notwithstanding anything to the contrary in this Section 7.3, the Board of Directors shall have the authority to enforce the restrictions set forth in this Section 7.3 against the Owners and occupants of the Retail Units.

7.4 Insurance Risk. No Unit or Common Elements shall be occupied or used by anyone in such a manner as to result in an increase in the cost of casualty or liability insurance on the Condominium or the risk of cancellation, or threat of cancellation, of any policy of insurance on the Condominium or any Unit or any part of the Common Elements.

7.5 Compliance. Each Owner shall comply and shall require all residents, servants, invitees, employees and visitors to his or her Unit to comply with the Act, the Declaration, these Bylaws and the Rules and Regulations adopted pursuant thereto.

7.6 Alterations. Except as otherwise permitted by these Bylaws or the Declaration, no Owner shall make or allow any structural alterations in or to any of his or her Units, or make or allow any alteration or installation on or to the Common Elements or allow others to do so, or maintain, decorate, alter or repair any part of the Common Elements, without the prior consent in writing of the Board of Directors. The Board of Directors shall consider the granting of such consent only after the Owner shall submit a complete set of architectural, mechanical, electrical or other relevant plans and specifications, which submission shall be reviewed by such architects and engineers as the Board of Directors shall deem appropriate. The Board shall provide a copy of such submission materials to the Declarant or its successors and assigns upon receipt. Whether or not such consent is granted, the Owner shall pay, upon demand and in advance, if so required by the Board of Directors, for such professional review. During the course of construction and after completion of same, the Board of Directors may cause its professional advisors to inspect the work to ensure that it is performed in compliance with the approved plans. The costs of such inspection(s) shall be paid by the Owner to the Board of Directors, upon demand. The Board shall provide reasonable advance notice to Declarant or its successors and assigns of its inspection to Declarant and Declarant or its contractors or agents may, but shall not be obligated to, inspect the work concurrently with the Board's professional advisors. Prior to commencement of construction, the Owner shall provide the Board of Directors with copies of all relevant building permits and evidence of due compliance with any other requirements of government bodies having jurisdiction regarding such work. Except as otherwise permitted by Section 7.16, no signage or graffiti visible from the exterior of a Unit, window display, window attachment, or lighting directed from a Unit to its exterior shall be permitted without the prior written approval of the Board of Directors; provided that this sentence shall not apply to draperies, blinds, and similar window coverings. An Owner may have removed by the Association, at such Owner's expense, a part of the partition wall separating contiguous Primary Units owned by an Owner provided that (i) such removal shall not interfere with any structural support elements or loadbearing partitions or columns or with any pipes, wires, cables, conduits or ducts or other mechanical systems and (ii) such Owner agrees in writing to have the Association restore such wall at such Owner's expense in the event that the ownership of the Units is

subsequently divided. Before proceeding with any approved alterations or improvements, the Owner shall, if the Board of Directors so requires, provide to the Association, at the expense of the Owner, a performance bond and a labor and materials bond, issued by a surety satisfactory to the Board of Directors, each in the amount of at least 125 percent of the estimated cost of such alterations or improvements or such other security as shall be satisfactory to the Association. In order to prevent damage to the structural integrity of any building forming part of the Condominium, in no event may any Owner, the Association, the Board of Directors or any other entity or any agents, employees, permittees, or licensees of the foregoing, drill, bore, or cut any holes into any floor or ceiling of the Condominium more than 3/4" in depth, and the Board of Directors shall not consent to any such actions unless engineering studies confirm to the Board in the Board's sole discretion that such drilling, boring or cutting shall not compromise the structural integrity of the Condominium. In no event shall an Owner or occupant install a molly bolt in perimeter or demising walls or penetrate such walls beyond the sheetrock.

7.7 Occupants of Corporate Unit. Whenever a Residential Unit is owned in whole or in part by a partnership, corporation, trust, or other entity, such an entity shall designate at the closing of the acquisition of its ownership interest one particular person or family that shall be entitled to be the primary occupant of the Residential Unit. Only such designated person or family, its servants and non-paying guests may occupy such Residential Unit. A different person or family may be so designated as the named user of a Residential Unit by written notice to the Association; provided, however, that no more than two such changes may be made in any calendar year.

7.8 Non-Interference. Each Unit shall be used only for such purpose and to such extent as will not overload or interfere with any Common Elements or the enjoyment thereof by the other Owners or occupants.

7.9 Nuisances. No nuisances or noxious or offensive activities shall be allowed in the Condominium nor shall any use or practice be allowed that is improper or offensive in the opinion of the Board of Directors or that unreasonably interferes with or is an unreasonable annoyance to the peaceful possession or proper use of the Condominium by other Owners or occupants or requires any alteration of or addition to any Common Element. The determination of acceptable commercial uses within the Condominium shall be made in accordance with Section 7.3. Residential Unit occupants and their guests shall exercise extreme care not to make or allow noises that may disturb other occupants or guests, including the use of musical instruments, radios, televisions, speakers and amplifiers. Televisions and speakers for audio equipment may not be mounted on or against perimeter walls or on floors of a Residential Unit without an adequate sound barrier to prevent vibration and transmission of bass sounds outside the Unit. Road noise, noise from mechanical systems of the Condominium, the elevators, air compressors and other incidental noises from a multi-family building, including, without limitation, from residents' use of the courtyard, library, plaza, common patio and kitchen, exercise and meeting rooms, patios or balconies in accordance with these Bylaws and the Rules and Regulations, shall not be considered nuisances. In addition, smells from the use of permitted barbeques on patios shall not be considered nuisances. Owners shall not discard or throw, or allow to be discarded or thrown, intentionally or otherwise, any items from the windows or the patios adjacent to their Units, including, without limitation, cigarettes or ashes. Owners shall not allow the storage or use of hazardous substances in their Units other than normal cleaning materials stored and used in accordance with applicable law. Owners and other

occupants shall not engage in any abusive or harassing behavior, either verbal or physical, or any form of intimidation or aggression directed at other Owners, occupants, guests, or invitees, or directed at the manager, its agents or employees, or vendors.

7.10 Unlawful or Improper Activities. No unlawful use shall be made of the Condominium or any part thereof, and all Legal Requirements shall be strictly complied with. Compliance with any Legal Requirements shall be accomplished by and at the sole expense of the Owner or Association, as the case may be, whichever is allowing or conducting the unlawful use or whichever shall have the obligation to maintain and repair the portion of the Condominium affected by any such Legal Requirement. Each Owner shall give prompt notice to the Board of Directors of any written notice received of the violation of any Legal Requirement affecting the Owner's Unit or Units or the Condominium. Notwithstanding the foregoing provisions, an Owner may, at such Owner's expense, defer compliance with and contest, by appropriate proceedings prosecuted diligently and in good faith, the validity or applicability of any Legal Requirement affecting any portion of the Condominium that such Owner is obligated to maintain and repair, and the Board of Directors shall cooperate with such Owner in such proceedings, provided that:

7.10.1 Such Owner shall pay and shall defend, save harmless, and indemnify the Board of Directors, the Association, and each other Owner against all liability, loss or damage that any of them respectively shall suffer by reason of such contest and any noncompliance with such Legal Requirement, including attorneys' fees and other expenses incurred;

7.10.2 Such Owner shall keep the Board of Directors advised as to the status of such proceedings; and

7.10.3 If any Owner conducts any activity or fails to comply with any Legal Requirement that increases the insurance premiums on insurance carried by the Association, or for which the Association is directly or indirectly responsible, such Owner shall pay such increased premium to the Association, upon demand, and if not so paid, such amount shall bear interest after the date of such demand at the rate provided in Section 7.3 of the Declaration.

7.11 Contested Legal Requirements. An Owner need not comply with any Legal Requirement so long as the Owner is contesting the validity or applicability thereof as provided in Section 7.10, provided that noncompliance shall not create a dangerous condition or constitute a crime or an offense punishable by fine or imprisonment, and that no part of the Condominium shall be subject to being condemned or vacated by reason of noncompliance or otherwise by reason of such contest. The Board of Directors may also contest any Legal Requirement without being subject to the conditions described in Section 7.10 as to the contest and may also defer compliance with any Legal Requirement, subject to the conditions contained in this Section 7.10 as to deferral of compliance by an Owner, and the costs and expenses of any contest by the Board of Directors shall be a common expense.

7.12 Improper Discharge. No Owner or occupant shall discharge, or permit to be discharged, anything into water lines, vents or flues of the Condominium that may violate applicable laws or regulations or might reasonably be anticipated to cause damage thereto or

reduce the life expectancy thereof (excepting normal wear and tear), spread odors or otherwise be harmful or offensive.

7.13 Limitation on Storage Areas.

7.13.1 Other than items placed by the Declarant or the Association, no furniture, packages or objects of any kind shall be placed in the lobbies, vestibules, corridors, stairways, or any other part of the Parking Units or Common Elements (other than the patios and balconies), except as allowed in Section 7. The courtyard, plaza, lobbies, vestibules, corridors, and stairs shall be used only for normal passage. The provisions hereof shall not apply to the Declarant until such time as all Primary Units have been initially sold and conveyed by the Declarant; however, the Declarant shall not use the Common Elements in such a manner as will unreasonably interfere with the use of the Residential Units for dwelling purposes.

7.13.2 Notwithstanding the provisions of Section 7.13.1, an Owner or occupant may place a doormat directly in front of the door to his or her Residential Unit, subject to limitations adopted by the Board of Directors from time to time regarding the dimensions, colors, design, materials, and similar matters.

7.13.3 An Owner who places or whose tenant or occupant places a doormat outside such Owner's Unit shall defend, indemnify and hold harmless the Association, its officers and directors, from any and all loss, liability or damages arising out of or relating to the presence or existence of such doormat.

7.13.4 Regardless of whether a doormat matches the dimensional or other objective requirements established by rule or regulation from time to time, the Board of Directors may order the removal of any doormat which it finds, in the sole and unfettered discretion of the Board, to be offensive or aesthetically objectionable, or which it finds to create a nuisance, obstruction or unreasonable risk to users of the Common Elements. The right of the Board of Directors so to order the removal of any doormat shall not place any legal obligation upon the Board to monitor doormats for safety or other purposes.

7.14 Tradesmen. Owners shall require their tradesmen to utilize exclusively the entrance, if any, designated by the Board of Directors for transporting packages, merchandise or any other objects.

7.15 Animals. No animals or fowl shall be raised, kept or permitted within the Condominium, except domestic dogs, cats, or other household pets, kept within a Primary Unit. No such dogs, cats or household pets shall be permitted to run at large or be kept, bred or raised for commercial purposes or in excess of four (4) per Primary Unit (other than fish). Any inconvenience, damage or unpleasantness caused by such pets shall be the responsibility of the respective Owners thereof. All dogs, cats or other permitted household pets (other than fish) shall be carried or maintained on a leash while within the confines of a Common Element. An Owner may be required to remove a pet after receipt of two notices in writing from the Board of Directors of violations of any Rule, Regulation or restriction governing pets within the Condominium. No animals of any kind shall be permitted to be kept within Storage Units.

7.16 Signs and Displays. All signage displayed to public view, whether from a Unit or Common Element, shall be subject to rules and regulations thereon adopted by the Board

of Directors pursuant to Section 7.27 except as otherwise provided herein. In no event shall any "for sale" or similar sign be placed in a window that is displayed to public view or any sign be placed on or in the vicinity of a common entry door of the Condominium, other than signs used by the Declarant or the Owners of the Retail Units to advertise Units for sale or lease, without the prior written approval of the Board of Directors, which shall not be unreasonably withheld, delayed or conditioned. The Owners of the Retail Units may, and may allow their tenants to, post signs for commercial purposes on the sign stanchions located on the exterior of the Condominium building, within their Primary Unit or elsewhere at a location on the exterior of the Retail Units, subject only to the requirements of applicable laws and ordinances and, with respect to signs on the exterior of the Retail Units at a location other than the sign stanchions, to Section 7.6. The Owners of the Retail Units may, and may permit their tenants to, also install window displays, window signs and display lighting for commercial purposes within the Retail Units, subject only to the requirements of applicable laws and ordinances and approval of the Board of Directors, which shall not be unreasonably withheld, conditioned or delayed. No sign shall be illuminated in a manner that unreasonably interferes with the enjoyment of any Unit.

7.17 Sidewalk Areas. Notwithstanding anything to the contrary in these Bylaws or the Declaration, the Owners of the Retail Units may, and may permit its tenants to, use and place items on the sidewalks or the ground level plaza (with respect to Unit R1 only) in front of the Retail Units for uses consistent with such Owners' or tenants' business in the premises, provided that such use (i) complies with all Legal Requirements, (ii) does not materially obstruct pedestrian access, and (iii) such Owner or tenant shall indemnify the Association for all claims, cost, expense or liability arising out of such use.

7.18 Trash. No part of any Unit or the Common Elements shall be used or maintained as a dumping area for rubbish, trash, garbage or other waste, other than designated common trash disposal areas. No such items shall be kept or maintained excepting sanitary containers in areas designated therefor.

7.19 Auctions or Open House. No Owner shall, when attempting to sell, lease or otherwise dispose of his Unit, or any personal property located therein, hold an "open house" or "auction" without the prior written approval of the Board of Directors of an access security management plan for the event. The Board shall approve any reasonable access security management plan.

7.20 Overloading. No Owner shall do anything to overload any part of a Unit or any part of the Common Elements.

7.21 Hot Tubs. No hot tubs or Jacuzzis may be installed on porches, balconies or patios.

7.22 Exercise, Library and Meeting Rooms. Use of the exercise, library and meeting rooms shall be limited to the Owners or occupants of Residential Units. An Owner or occupant wishing to reserve use of the exercise, library or meeting room for an event shall do so by written notice to the Association, which shall maintain a calendar for keeping records of such reservations. If no other permitted user has previously reserved the exercise, library or meeting room, as applicable, at the time and date specified in the foregoing notice, the Association shall reserve the exercise and meeting room for such Owner or occupant at the requested date and

time. The Association may charge the user a use fee, damage deposit and cleaning fee, in such amounts as the Association deems reasonable, and the Association may require the permitted user to provide evidence of insurance coverages, with policy limits, provisions and deductibles as are required by the Association for events held in the exercise, library and meeting room. Except as otherwise provided herein for reserved events, use of machines, furnishings and equipment in the exercise and meeting room shall be on a first-come, first-served basis and shall be subject to the Rules and Regulations as may be adopted by the Board of Directors from time to time pursuant to Section 7.27.

7.23 Courtyard. The hours during which the courtyard and common patio and kitchen for the Residential Units may be used by Owners or occupants of Residential Units shall be generally limited to daylight hours, provided, that the Board may allow in writing other hours of use for a special occasion or by appointment, but in any event not before 8:00 a.m. or beyond 10:00 p.m. The courtyard, common patio and kitchen may not be used for gatherings, public performances, or commercial purposes without prior written approval of the Board. Smoking is not allowed in the courtyard, common patio or kitchen. Use of the courtyard shall also be subject to the Rules and Regulations adopted by the Board from time to time as provided in Section 7.27.

7.24 Window Coverings. All window coverings visible from the exterior of the Condominium shall be of the same color palette as specified by the Declarant, samples of which are in the homeowner specification books provided to the Association by the Declarant.

7.25 Patios. Owners and occupants may use only natural gas barbeques on the patios, in connection with the natural gas hook-ups. Owners and occupants shall not use the natural gas hook-up on the patios for any appliance other than a natural gas barbeque. In no event may charcoal or propane barbeques be used on the patios. In no event may deep fryers be used on any part of the Condominium. In no event may speakers or other audible audio devices be placed or used on the patios. Owners and occupants may place well-maintained patio furniture and potted plants with drip containers on the patio reserved for their use, provided that in no event may drip irrigation systems be used for such plants and so long as none of the foregoing items protrude from or overhang the patio. Other items may be allowed to be placed on patios or hung from patio walls or railings only with the prior written consent of the Board of Directors or pursuant to Rules and Regulations adopted by the Board pursuant to Section 7.27. In no event shall items be placed on a patio that collectively exceed 60 pounds per square foot of space occupied by such item, including the weight of plants immediately after watering. Owners and occupants shall promptly clean up debris and water on their patio.

7.26 Over-the-Air Reception Devices. Radio and television dishes and antennas and other over-the-air reception devices ("OTARDs") that are subject to the FCC's Over-the-Air Reception Devices Rule may be installed on an Owner's Limited Common Elements to the extent feasible and painted so as to camouflage the OTARD. If such a location is not feasible then the Owner may apply to the Board for an acceptable location on the General Common Elements for the OTARD. In the event of such lack of feasibility, the Board shall permit the Owner to install the OTARD on the General Common Elements in a specific location where it is feasible to obtain the desired service as is reasonably determined by the Board. Prior to installation of any OTARD, the Owner shall submit to the Board detailed plans and specifications for any OTARD that the Owner wishes to install on the Common Elements

(General Common Elements or Limited Common Elements), and shall not commence any construction, installation or operation of any such OTARD until the plans and specifications have been approved in writing by the Board. The Board may condition its approval upon, among other things, the provision of reasonable security to insure the performance of the Owner's obligations under this Section 7.26. Any such OTARD shall be painted as directed by the Board so as to camouflage the installation if that will not interfere with the desired service. The Board shall have the right to supervise the installation and removal of any such OTARD. The Board shall also have the right to require landscaping or other materials be installed at the Owner's expense to reasonably screen any such OTARD from view and to enforce reasonable OTARD safety and maintenance requirements. Board approval shall also be required for any OTARD mast installation that would be more than 12 feet in height or any OTARD dish that would be more than three feet in diameter.

7.27 Association Rules and Regulations. In addition to the foregoing requirements, the Board of Directors from time to time may adopt, modify, or revoke such Rules and Regulations governing the conduct of persons and the operation and use of the Units and the Common Elements as it may deem necessary or appropriate in order to assure the peaceful and orderly use and enjoyment of the Condominium including, without limitation, establishment of reasonable administrative fees, such as fees for new owner set-up and owner's packet, move-in and move-out fees, etc. Any such Rules and Regulations may be amended, modified or revoked by the Owners in the same manner as these Bylaws. Any rules or regulations affecting the use of the Retail Units must be approved by a majority of the Owners of the Retail Units. Any such Rules and Regulations may be amended, modified or revoked by the Owners in the same manner as these Bylaws. A copy of the Rules and Regulations, upon adoption, and a copy of each amendment, modification or revocation thereof, shall be delivered by the Board of Directors promptly to each Owner and shall be binding upon all Owners and occupants of all Units from the date of delivery.

7.28 Activities of Declarant. Nothing in this Article 7 or in the other provisions of these Bylaws shall be construed to limit, modify, or otherwise restrict the rights of Declarant pursuant to the Declaration with respect to the planning, designing, developing, constructing, and sale of improvements on the Property.

7.29 Entry System. The entry system for the Condominium may utilize a channel of the cable television service serving the Condominium unless modified by the Board or the service provider.

8. MAINTENANCE OF CONDOMINIUM PROPERTY; CONDEMNATION.

8.1 Maintenance and Repair. Except as otherwise provided in the Declaration for damage or destruction caused by casualty:

8.1.1 Units. All maintenance of and repairs to any Primary or Storage Unit shall be made by the Owner of such Unit or Units, as described in Section 13.2 of the Declaration, to the extent not covered by the Association's insurance. The Retail Unit Owners shall also be jointly and severally responsible for maintenance and repair of the limited Common Element bathroom facilities (including all fixtures, plumbing, and electrical lines located therein) reserved for the use of the Retail Units in Section 6 of the Declaration and as shown on the Plans.

An Owner shall make no repair or alteration or perform any other work on his or her Unit or Units that would jeopardize the soundness or safety of the Condominium, or reduce the value thereof or impair any easement or other right, unless the written consent of all Owners affected is also obtained.

8.1.2 Common Elements, Parking Units and Association Property.

Except as otherwise provided by Section 13 of the Declaration, all inspection, maintenance, repairs and replacements to the Common Elements, Parking Units and Association Property shall be made by the Association as required in Section 13 of the Declaration and in accordance with the Maintenance Plan. The Association's expenses for such activities shall be charged to the Owners as a Retail Expense or a Residential Expense, as applicable, in accordance with Section 7.1 of the Declaration; provided, that if such inspection, maintenance, repairs or replacement have been necessitated by acts or omissions of an Owner by reason of which the Owner is responsible under applicable law or under these Bylaws for all or a portion of the costs thereof, except as otherwise provided by Section 22.2 of the Declaration, such costs shall be charged solely to the Owner so responsible, and provided further, that the each Owner of a Retail Unit shall be responsible, at its expense, for keeping those portions of loading areas within 40 feet of entrance ways free of debris, trash or materials associated with commercial activity. Furthermore, each Owner of a Residential Unit shall keep the patios adjacent to such Owner's Unit clean and free of debris, notwithstanding that such patios are Common Elements. However, should actual collection of such costs from the responsible Owner within a reasonable period of time prove impossible after reasonable collection efforts, the uncollected portion may be charged to all Owners as a common expense in accordance with Section 7.1 of the Declaration, subject to reimbursement of any amounts later collected from the responsible Owner. If the Mortgagee of any Primary Unit determines that the Board is not providing an adequate maintenance, repair, and replacement program for the Common Elements, such Mortgagee, at its option, may deliver a notice to the registered agent of the Association, as required pursuant to ORS 100.550, setting forth the particular defect(s) which it believes exists in the maintenance, repair, and replacement program. If the specified defect(s) are not corrected within 60 days after receipt of such notice, then the Mortgagee, upon written notice to the registered agent that it is exercising its proxy rights thereunder, shall have the right to attend succeeding annual or special meetings of the Association and to cast a vote for each Primary Unit on which it holds a Mortgage on all business coming before such meeting, which proxy rights shall continue until the defect(s) described in the notice are corrected.

8.1.3 Repairs by Association. The Association may make repairs that an Owner is obligated to make and that he or she does not make within a reasonable time. If such repairs are of an emergency nature (in that the repairs must be promptly made to prevent further or imminent potential damage to the Unit involved, other Units or any Common Element), the Association may make such repairs immediately, without notice to the Owner, if he or she is not available for reasonable notification within the time frame that the nature of the emergency shall reasonably afford. The Association shall indemnify its agents, employees and other of its representatives from any and all liability to any Owner incurred by reason of any reasonable exercise of the right of entry afforded in the Declaration or these Bylaws to effect emergency repairs. The Association shall have no liability to an Owner for any use of its right of entry or right to make emergency repairs if it shall have reasonable cause to believe that such action is required. An Owner shall be deemed to have consented to having such repairs done to his or her Unit by the Association. An Owner shall reimburse the Association in full for the cost of such

repairs, except to the extent covered by insurance proceeds received by the Association, including any legal or collection costs incurred by the Association in order to collect the costs of such repairs. All such sums of money shall bear interest from the due date therefor at the rate provided in Section 7.3 of the Declaration. The Association may collect all such sums of money in such installments as the Board of Directors may determine, which installments shall be added to the monthly contributions towards the common expenses of such Owner, after the Owner's receipt of notice thereof. All such payments are deemed to be additional contributions towards the common expenses and recoverable as such.

8.2 Additions, Alterations, or Improvements. Except as otherwise permitted by the Declaration or these Bylaws, an Owner shall not, without first obtaining the written consent of the Board of Directors (if so required by Section 7.6) and satisfying the other requirements provided for in Section 7.6, as applicable, make or permit to be made any structural alteration, improvement, or addition in or to his or her Unit or Units, or in or to the exterior of any building forming part of the Condominium or any Common Element. An Owner shall make no repair or alteration or perform any other work on his or her Unit or Units that would jeopardize the soundness or safety of the Condominium, or reduce the value thereof or impair any easement or other right, unless the written consent of all Owners affected is also obtained. Other than as permitted by the Declaration or these Bylaws, an Owner shall not modify, alter, add to, paint or decorate any portion of the exterior of any building forming part of the Condominium or any Common Element without first obtaining the written consent of the Board of Directors and satisfying the other requirements of Section 7.6. In order to prevent damage to the structural integrity of any building forming part of the Condominium, in no event may any Owner, the Association, the Board of Directors or any other entity or any agents, employees, permittees, or licensees of the foregoing, drill, bore, or cut any holes into any floor or ceiling of the Condominium more than 3/4" in depth, and the Board of Directors shall not consent to any such actions unless engineering studies confirm to the Board in the Board's sole discretion that such drilling, boring or cutting shall not compromise the structural integrity of the Condominium.

8.3 Failure to Follow Maintenance Plan. If the Association fails to follow the maintenance and inspection requirements contained in the Maintenance Plan described in Section 3.2.23 above, then the Association hereby waives any claim it might otherwise have against Declarant and its design professionals, contractors and subcontractors and their consultants, including without limitation, all of their officers, members, directors, employees, agents, brokers and affiliates, for loss or damage to the extent the same results from such failure to follow the Maintenance Plan, and shall indemnify such persons and entities from and against claims by Owners or other persons or entities for loss or damage resulting from such failure.

9. INSURANCE.

9.1 Types. Each Owner shall be responsible for obtaining, at his own expense, insurance covering his property not insured under Section 9.1.1 below and against his liability not covered under Section 9.1.2 below, unless the Association agrees otherwise. For the benefit of the Association and the Owners, the Board of Directors shall obtain and maintain at all times, and shall pay for out of the common expense funds, the following insurance:

9.1.1 Insurance covering loss or damage under an all-risk replacement cost policy, which coverage must include fire, extended coverage, vandalism and malicious mischief (but need not include flooding and earthquake coverages), and such other coverages, including "all-risk" coverage, which the Association may deem desirable, for not less than the full insurable replacement value, including the cost of replacement in compliance with the then applicable building codes, of the Units and Common Elements, including any fixtures (including built-in kitchen appliances), building service equipment, and common personal property, Association Property and supplies belonging to the Association. Such policy or policies shall name the Association and the Owners as insureds, as their interests may appear, and shall provide for a separate loss payable endorsement in favor of the Mortgagee of each Unit, if any. To the extent such policy is available at a commercially reasonable cost, no such policy shall contain a deductible exceeding the lesser of Ten Thousand Dollars (\$10,000.00), adjusted by any increase in the Consumer Price Index - All Items - for all urban consumers as published by the U.S. Bureau of Labor Statistics (or any comparable substitute index, if such shall be discontinued), the base year being 2006, or one percent of the face amount of the policy.

9.1.2 A policy or policies insuring the Association, the Board of Directors, the Owners and the managing agent, against liability to the public or to the Owners, and their employees, invitees, or tenants, incident to the supervision, control, operation, inspection, maintenance, or use of the Condominium, including all Common Elements, public ways, and any other areas under the supervision of the Association. There may be excluded from such policy or policies coverage of an Owner (other than as a member of the Association or Board of Directors) for liability arising out of acts or omissions of such Owner and liability incident to the ownership and/or use of the part of the Condominium as to which such Owner has the exclusive use or occupancy. Limits of liability under such insurance shall not be less than One Million Dollars (\$1,000,000.00) on a combined single limit basis. In addition to the indexing provided under Section 12.7 of these Bylaws, the foregoing policy limits of liability shall be increased, in the sole discretion of the Board of Directors. Such policy or policies shall be issued on a comprehensive liability basis and shall provide cross liability endorsement wherein the rights of the named insured under the policy or policies shall not be prejudiced as respects any action against another named insured.

9.1.3 Worker's compensation insurance to the extent necessary to comply with any applicable laws.

9.1.4 Directors' and officers' liability insurance with coverage in an amount of not less than One Million Dollars (\$1,000,000), subject to a reasonable deductible which shall be determined by the Board of Directors.

9.1.5 Fidelity insurance for all officers, directors, trustees and employees of the Association and all other persons handling or responsible for funds of or administered by the Association. In the event the Association has retained a manager, such manager shall maintain fidelity insurance for its officers, employees and agents handling or responsible for funds of, or administered on behalf of, the Association. The cost of such insurance shall be at the expense of the Association. The total amount of fidelity insurance coverage required shall be based upon the best business judgment of the Board of Directors. In no event, however, may the aggregate amount of such insurance be less than the sum equal to three months' aggregate

assessments on all units plus reserve funds. Such fidelity insurance shall name the Association as obligee and shall contain waivers by the issuers of the insurance of all defenses based upon the exclusion of persons serving without compensation from the definition of "employees" or similar terms or expressions. The insurance shall provide that it may not be canceled or substantially modified (including cancellation for nonpayment of premium,) without at least ten (10) days' prior written notice to the Association and each servicer on behalf of the Federal National Mortgage Association ("FannieMae").

9.2 Mandatory Policy Provisions. Insurance obtained by the Association shall be governed by the following provisions:

9.2.1 All policies shall be written with the State of Oregon or a company licensed to do business in the State of Oregon acceptable to FannieMae which falls into a "B" or better general policyholder's rating or a "6" or better financial performance index rating in Best's *Insurance Reports*, an "A" or better general policyholder's rating and a financial size category of "VIII" or better in Best's *Insurance Reports – International Edition*, an "A" or better rating in Demotech's *Hazard Insurance Financial Stability Ratings*, a "BBBq" qualified solvency rating or a "BBB" or better claims-paying ability rating in Standard and Poor's *Insurer Solvency Review*, or a "BBB" or better claims-paying ability in Standard and Poor's *International Confidential Rating Service*. Should reinsurance be involved, the Board of Directors shall use its best efforts to obtain such coverage from a reinsurer having a size rating of at least "AAA".

9.2.2 All losses under policies hereafter in force placed by the Association regarding the Condominium shall be settled exclusively by the Board of Directors or its authorized representative. The Board of Directors may give such releases as are required, and any claimant, including the Owner of a damaged Unit, shall be bound by such adjustment; provided, however, that the Board of Directors may, in writing, authorize an Owner to adjust any loss to his or her Unit or Units.

9.2.3 Any Owner who obtains individual insurance policies covering any portion of the Condominium other than his or her personal property and fixtures (other than built-in kitchen appliances) shall file a copy of such individual policy or policies with the Association within 30 days after the purchase of such insurance.

9.2.4 Notwithstanding the provisions of these Bylaws, there may be named as an insured, on behalf of the Association, the Association's authorized representative, including any trustee with whom the Association may enter into any Insurance Trust Agreement, or any successor to such trustee. Such insurance trustee shall have exclusive authority to negotiate losses under any property or liability insurance policy. Each Owner appoints the Association, or any insurance trustee or substitute trustee designated by the Association, as attorney-in-fact for the purpose of purchasing and maintaining such insurance including: the collection and appropriate disposition of the proceeds thereof, the negotiation of losses and execution of releases of liability, the execution of all documents, and the performance of all other acts necessary to accomplish

such purchase. The Association or insurance trustee shall receive hold, or otherwise properly dispose of any proceeds of insurance in trust for Owners and their first mortgage holders, as their interests may appear.

9.2.5 All property insurance policies shall contain a "Special Condominium Endorsement" or its equivalent providing for the following: recognition of any Insurance Trust Agreement, a waiver of the right of subrogation against Owners individually, that the insurance is not prejudiced by any act or neglect of individual Owners that is not in the control of such Owners collectively, and that the policy is primary in the event the Owner has other insurance covering the same loss.

9.2.6 For purposes of this Section 9, insurance policies are unacceptable where (i) under the terms of the insurance carrier's charter, bylaws or policy, contributions or assessments may be made against FannieMae, the designee of FannieMae, or the Association Owners, or (ii) by the terms of the carrier's charter, bylaws or policy, loss payments are contingent upon action by the carrier's board of directors, policyholders or members, or (iii) policy includes any limiting clauses (other than insurance conditions) that could prevent collecting insurance proceeds.

9.2.7 All policies required by this Section 9 shall provide that they may not be canceled or substantially modified without at least ten (10) days' prior written notice to the Association and to each holder of a first mortgage which is listed as a scheduled holder of a first Mortgage in the insurance policy. Evidence of insurance shall be issued to each Owner and Mortgagee upon request.

9.2.8 Each Owner shall be required to notify the Board of Directors of all improvements made by the Owner to his or her Unit, the value of which is in excess of Two Thousand Dollars (\$2,000). Nothing in this paragraph shall permit an Owner to make improvements without first obtaining the approval of the Board of Directors pursuant to these Bylaws.

9.3 Discretionary Provisions. The Board of Directors shall make every effort to secure insurance policies that will provide for the following:

9.3.1 A waiver of subrogation by the insurer as to any claims against the Association, the Board of Directors, the manager, the Owners and their respective servants, agents, household members, and guests, except for arson and fraud;

9.3.2 A provision that any master policy on the Condominium cannot be canceled, invalidated, or suspended, nor coverage denied thereunder, on account of the conduct of any one or more individual Owners;

9.3.3 A provision that any master policy on the Condominium cannot be canceled, invalidated, or suspended on account of the conduct of any officer or employee of the Board of Directors or the manager without prior demand in writing that the Board of Directors or manager cure the defect;

9.3.4 A provision that any “no other insurance” clause in any master policy exclude individual Owners’ policies from consideration, and a waiver of the usual proration clause with respect to such policies;

9.3.5 A provision that the insurer issue subpolicies specifying the portion of any master policy earmarked for each Owner’s interest and that until the insurer furnishes written notice and a grace period to the Mortgagee insured under the loss payable clause thereof, the Mortgagee’s coverage is neither jeopardized by the conduct of the mortgagor-Owner, the Association, or other Owners, nor canceled for nonpayment of premiums;

9.3.6 A rider on any master policy patterned after “Use and Occupancy” insurance which will provide relief from monthly assessments while a Unit is uninhabitable by the payment of the Condominium expenses thereof and any other fixed costs, including, but without being limited to, taxes, rent, insurance, and Mortgage payments. The proceeds from any casualty policy, whether held by the Association or an Owner, payable with respect to any loss or damage to the Common Elements, shall be held in trust for the benefit of all insureds as their interests may appear;

9.3.7 A waiver of the insurer’s right to determine whether the damage should be repaired. If reasonably available, the policy or policies should contain a stipulated amount clause, or determinable cash adjustment clause, or similar clause, to permit a cash settlement covering specified value in the event of destruction and a decision not to rebuild;

9.3.8 Waivers of any defense based on co-insurance or of invalidity arising from the conduct or any act or omission or breach of a statutory condition of or by any insured;

9.3.9 A provision that the same shall be primary insurance in respect of any other insurance carried by any Owner;

9.3.10 An “inflation guard” endorsement;

9.3.11 An endorsement providing coverage with respect to changes that may be required under applicable codes or ordinances to undamaged portions of the Condominium in the event of a casualty affecting a portion of the Condominium; and

9.3.12 A provision that any insurance trust agreement will be recognized.

9.4 Additional Requirements.

9.4.1 Prior to obtaining any policy or policies of insurance under Section 9.1.1, or any renewal or renewals thereof and if any first Mortgagee holding Mortgages on at least 75 percent of the Primary Units so requires, or at such other times as the Board of Directors may deem advisable, the Board of Directors shall obtain an appraisal from an independent qualified appraiser, of the “full replacement cost” of the Condominium, for the purpose of determining the amount of insurance to be obtained pursuant to Section 9.1.1, and the cost of such appraisal shall be a common expense to be allocated in accordance with Section 7.1 of the Declaration; provided, however, that the full replacement cost of the Condominium for the

policy or policies of insurance placed in force upon recording of these Bylaws or the Declaration shall be determined by the Declarant.

9.4.2 No Mortgage may be placed against any Unit unless the Mortgagee agrees to waive any contractual or statutory provision giving the Mortgagee the right to have the proceeds of any insurance policy or policies applied on account of the Mortgage and thereby prevent application of the proceeds of any insurance policy or policies towards the repair of the property pursuant to the provisions of these Bylaws. This Section 9.4.2 shall be read without prejudice to the right of a Mortgagee to vote on or to consent to certain matters, if the Mortgage itself contains a provision giving the Mortgagee that right, and also to the right of any Mortgagee to receive the proceeds of any insurance policy, if the insured property is not repaired.

9.4.3 A certificate or memorandum of all insurance policies and endorsements thereto shall be issued as soon as possible to each Owner and a duplicate original or certified copy of the policy or policies to each Mortgagee. Renewal certificates or certificates of new insurance policies shall be furnished to each Owner and Mortgagee not later than 10 days before the expiration of any current insurance policy. The master policy (or a copy thereof) for any insurance coverage shall be kept by the Association in its office, available for inspection by an Owner or Mortgagee on reasonable notice to the Association.

9.4.4 No insured, other than the Association, shall be entitled to amend any policy or policies of insurance obtained and maintained by the Association, or to direct that loss shall be payable in any manner other than as provided in these Bylaws.

9.5 By the Owner. It is acknowledged that the foregoing provisions specify the only insurance required to be obtained and maintained by the Association and that the following insurance shall be obtained and maintained by each Owner, as specified.

9.5.1 Insurance on any additions or improvements made by the Owner to his or her Unit or Units shall be purchased and maintained for the full insurable value thereof, to the extent not covered by the Association's Insurance Policy, unless the Owner presents in writing to the Board of Directors evidence that the additions or improvements made by the Owner to his or her Unit are insurable under the insurance issued pursuant to Section 9.1.1 and the Board of Directors, after consultation with the Association's insurer, concurs that such additions or improvements are insured under such insurance and, if necessary, the Association's insurer undertakes the requisite action to cause the additions or improvements to be added to the policy issued pursuant to Section 9.1.1. Insurance also shall be purchased by the Owner for furnishings, fixtures (other than built-in kitchen appliances), equipment, decorating and personal property and chattels of the Owner contained within his or her Unit or Units, and his or her personal property and chattels stored elsewhere on the Property, including his or her automobile or automobiles, and for loss of use and occupancy of his Unit or Units in the event of damage. Owners shall be responsible for insuring the deductible amount under the Association's policies. The Association shall notify all Owners of the amount of the deductible under the Association policies, and to the extent reasonably practicable, the Association shall give at least 30 days' notice to the Owners of any increase in the deductible proposed in renewal or replacement insurance policies. Any such policy or policies of insurance shall contain waivers of subrogation against the Association, its manager, agents, employees and servants, and against the other Owners and any members of their households, except for vehicle impact, arson and fraud.

9.5.2 Public liability insurance in the amount reasonably set by the Board of Directors no more often than every three years, covering any liability of any Owner to the extent not covered by any public liability and property damage insurance obtained and maintained by the Association, including, without limitation, damages caused by fixtures, equipment, or personal property under the custody, care, or control of the Owner; provided that the Board of Directors may require the Retail Unit Owners to maintain public liability insurance in an amount greater than the amount required of the Owners of the Residential Units.

9.5.3 If the Board of Directors is unable to obtain the rider specified in Section 9.3.6, then the Owner shall obtain and pay the expense of such rider.

9.5.4 In the case of the Retail Units being used for commercial purposes as permitted in Section 9 of the Declaration, such other insurance coverages as are customarily maintained by owners of businesses comparable to those operated within such Unit.

9.6 FannieMae and GNMA Requirements. Notwithstanding any other provisions of these Bylaws, the Association shall continuously maintain in effect such casualty, flood and liability insurance and a fidelity bond meeting the insurance and fidelity requirements for condominium projects established by FannieMae and Government National Mortgage Association, so long as either is a Mortgagee or Owner of a Unit within the Condominium, except to the extent such coverage is not available or has been waived in writing by FannieMae or Government National Mortgage Association. FannieMae or FannieMae's servicer, its successors and assigns, shall be named as a mortgagee in the Association's policies.

10. AMENDMENTS TO BYLAWS.

10.1 How Proposed. Amendments to the Bylaws shall be proposed by either a majority of the Board of Directors or by Owners holding at least 33 percent of the voting power of the Association. The proposed amendment must be reduced to writing and shall be included in the notice of any meeting at which action is to be taken thereon.

10.2 Adoption. A resolution adopting a proposed amendment may be proposed by either the Board of Directors or by the Owners and may be approved by a majority of the Owners at a meeting called for this purpose. Owners not present at the meeting considering such amendment may express their approval in writing or by proxy delivered to the Board of Directors at or prior to such a meeting. Any resolution shall be approved by at least a majority of the Owners, except that any resolution containing an amendment relating to age restrictions, pet restrictions, limitations on the number of persons who may occupy a Primary Unit and limitations on leasing or rental of Primary Units shall be approved by at least 75 percent (75%) of the voting power of the Association, and except that any provision of these Bylaws that is required to be in the Declaration may be amended only in accordance with the requirements governing amendment of the Declaration. Notwithstanding the foregoing, these Bylaws may not be amended in a manner that eliminates or impairs rights or privileges pertaining to the Retail Units without the approval of a majority of the Owners of such Units. In addition to the foregoing approval requirements, amendment of the following provisions of these Bylaws shall require the prior written approval of at least 51 percent (51%) of holders of first Mortgages on Primary Units (based upon one vote for each first Mortgage held) (i) Section 8.1, which

addresses maintenance and repair; (ii) Article 9, which addresses insurance requirements; and (iii) any other provision of these Bylaws which expressly benefits Mortgagees of Units or insurers or guarantors of such Mortgages. Any approval of a Mortgagee required under this Section 10.2 may be presumed by the Association if the Mortgagee fails to submit a response to a written proposal for an amendment to these Bylaws within thirty (60) days after it receives notice of such proposal by certified or registered mail, return receipt requested. For so long as Declarant remains the owner of one or more Primary Units, the Bylaws may not be modified, added to, amended or repealed so as to eliminate, change, or impair any rights, privileges, easements, licenses or exemptions granted therein or herein to the Declarant or its designee, or otherwise adversely affect the Declarant or such designee, without the Declarant's or such designee's prior written consent in each instance.

10.3 Execution and Recording. An amendment shall not be effective until certified by the Chairperson and Secretary of the Association, approved by the Real Estate Commissioner of the State of Oregon if required by law, and recorded in the deed records of Multnomah County, Oregon as required by law.

10.4 Rights of Declarant. Nothing in this Article 10 shall limit the right of the Declarant to approve amendments to the Bylaws pursuant to Section 14.9 of the Declaration.

11. LITIGATION.

11.1 By Less than All Owners. If any action is brought by one or more but less than all Owners on behalf of the Association and recovery is obtained, the plaintiff's expenses, including reasonable counsel's fees, shall be a common expense; provided, however, that if such action is brought against all of the Owners or against the Board of Directors, the officers, employees, or agents thereof, in their capacities as such, with the result that the ultimate liability asserted would, if proved, be borne by all the Owners, the plaintiff's expenses, including counsel's fees, shall not be charged to or borne by the other Owners, as a common expense or otherwise.

11.2 Complaints Against. Complaints brought against the Association, the Board of Directors or the officers, employees, or agents thereof, in their respective capacities as such, or against the Property as a whole, shall be directed to the Board of Directors, which shall promptly give written notice thereof to the Owners and any Mortgagees who have requested notice thereof and shall be defended by the Board of Directors, and the Owners and Mortgagees shall have no right to participate other than through the Board of Directors in such defense. One or more Owners shall have the right to enjoin, abate, or remedy by appropriate legal proceedings any failure by the Association or the Board of Directors to comply with the provisions of the Declaration, these Bylaws, or any Rule or Regulation. Complaints against one or more, but less than all of the Owners, shall be directed to such Owners, who shall promptly give written notice thereof to the Board of Directors and to the Mortgagees having an interest in such Units, and shall be defended by such Owners.

11.3 Mediation. Prior to initiating litigation, arbitration or an administrative proceeding in which the Association and a Unit Owner have an adversarial relationship, all claims shall first be submitted to mediation within Multnomah County, Oregon with any dispute resolution program available that is in substantial compliance with the standards and guidelines adopted under ORS 36.175, as it may be amended. The foregoing requirement does not apply to

circumstances in which irreparable harm to a party will occur due to delay or litigation or an administrative proceeding initiated to collect assessments, other than assessments attributable to fines.

11.4 Limitations on Actions. Notwithstanding any other provision of the Declaration or these Bylaws, the Association shall not expend or commit to expend in excess of \$2,500 for attorneys' fees and costs unless first approved by at least 75 percent of the outstanding votes of the Owners. The foregoing limitation shall not apply to actions for delinquent assessments or other charges under the Declaration or these Bylaws, for actions initiated by the Association during Declarant's period of administrative control pursuant to Section 20 of the Declaration; for actions challenging ad valorem taxation or condemnation proceedings; initiated against any contractor or vendor hired by the Association or supplier of goods and services to the Association; to defend claims filed against the Association or to assert counterclaims in proceedings instituted against it; actions to appoint a receiver pursuant to Section 5.9 of these Bylaws; actions to summarily abate and remove a structure or condition that violates the Declaration or these Bylaws; or for the defense of the Association or the Board of Directors of an action or proceeding brought against the Association or the Board of Directors (except for non-mandatory counterclaims).

11.5 No Attorneys' Fees. Except as specifically provided for in the Declaration or these Bylaws, no party in an arbitration, mediation or other proceeding shall be entitled to recover costs and attorneys' fees in connection therewith.

11.6 Suits Against Declarant. Declarant shall have the right to be present at any meeting of the Association during which the Board of Directors or the Owners vote on whether to initiate legal action against Declarant. The Board of Directors shall provide Declarant with at least 10 days written notice of the time and place of any such meeting.

11.7 Initial Dispute Resolution Procedures. In the event of a claim by the Association or any Owner against Declarant or any contractor, subcontractor, or supplier for a construction defect, the parties shall first comply with the provisions contained in ORS 701.550 to 701.595. In the event the claim is not for a construction defect, but relates to a claimed defect in the condition of the project, the parties shall follow the same procedures as set forth in such provisions, except that the notice of defect shall include a statement of the basis upon which the recipient is claimed to be liable for the defect. Compliance with the procedures contained in this Section 11.7 shall be a condition precedent to mediation, arbitration or litigation of any such claims.

11.8 Reports on Litigation. The Board of Directors shall provide written reports to the Owners and the Declarant, its successors and assigns from time to time (but in any event no less often than every six (6) months explaining the status of any pending claim, litigation, mediation or arbitration in which the Association is involved.

12. MISCELLANEOUS.

12.1 Notices. All notices to the Association or to the Board of Directors shall be sent care of the managing agent, or if there is no managing agent, to the principal office of the Association or to such other address as the Board of Directors may hereafter designate from time to time by written notice thereof to each Owner. All notices to any Owner shall be sent to such

address as may have been designated by him from time to time, in writing, to the Board of Directors, or if no address has been designated, then to the Owner's Primary Unit.

12.2 Waiver. No restriction, condition, obligation, or provision contained in these Bylaws shall be deemed to have been abrogated or waived by reason of any failure to enforce the same, irrespective of the number of violations or breaches thereof which may occur.

12.3 Invalidity; Number; Captions. The invalidity of any part of these Bylaws shall not impair or affect in any manner the validity, enforceability or effect of the remainder of these Bylaws. As used herein, the singular shall include the plural, and the plural the singular. The masculine and neuter shall each include the masculine, feminine and neuter, as the context requires. All captions used herein are intended solely for convenience of reference and shall in no way limit any of the provisions of these Bylaws.

12.4 Action Without a Meeting. Any action that the Act, the Declaration or the Bylaws require or permit the Owners or Board of Directors to take at a meeting may be taken without a meeting if a consent in writing setting forth the action so taken is signed by all of the Owners or Directors entitled to vote on the matter. The consent, which shall have the same effect as a unanimous vote of the Owners or the Board of Directors, as the case may be, shall be filed in the records of minutes of the Association. For votes of the Owners by written ballot, the Board of Directors shall provide Owners with at least 10 days' notice before written ballots are mailed or otherwise delivered. The notice shall state the general subject matter of the vote by written ballot, the right of Owners to request secrecy procedures specified in ORS 100.425, the date after which ballots may be distributed, the date and time by which any petition must be received by the Board requesting secrecy procedures, and the address where such a petition may be delivered. If, at least three (3) days before written ballots are scheduled to be mailed or otherwise distributed, at least 10 percent of the Owners petition the Board of Directors requesting secrecy procedures, a written ballot must be accompanied by a secrecy envelope, a return identification envelope to be signed by the Owner, and instructions for mailing and returning the ballot. Written ballots that are returned in secrecy envelopes may not be examined or counted before the deadline for returning ballots has passed. Notwithstanding the foregoing, action by written ballot may not substitute for the Turnover Meeting or the annual meeting of the Association.

12.5 Conflicts. These Bylaws are intended to comply with the Act and the Declaration. In case of any irreconcilable conflict, the Act and Declaration shall control over these Bylaws, any amendments hereto or any Rules and Regulations adopted hereunder.

12.6 Liability Survives Termination. The sale or other disposition of his Unit or Units shall not relieve or release any former Owner from any liability or obligation incurred or in any way connected to such ownership, nor shall such termination impair any rights or remedies that the Association may have against such former Owner arising out of or in any way connected with such ownership and the covenants and obligations incident thereto.

12.7 Indexing. Whenever any dollar amount is specified in these Bylaws, such amount shall be automatically adjusted each January 1 based upon any changes in the Consumer Price Index - All Items - for all urban consumers published by the U.S. Bureau of Labor

